

1.8MHz Zero-Drift CMOS Rail IO Opamp with

Features

- Single-Supply Operation from +1.8V ~ +5.5V
- Rail-to-Rail Input / Output
- Gain-Bandwidth Product: 1.8MHz (Typ@25°C)
- Low Input Bias Current: 20pA (Typ@25°C)
- Low Offset Voltage: 30μV (Max@25°C)
- Zero Drift: 0.01μV/°C (Typ)
- Quiescent Current: 180μA per Amplifier (Typ)
- Operating Temperature: -40°C ~ +85°C
- Embedded RF Anti-EMI Filter
- Small Package:
 AD8551 Available in SOT23-5、DFN-8 MSOP-8and SOP-8 Packages
 AD8552 Available in MSOP-8、DFN-8 and SOP-8 Packages
 AD8554 Available in SOP-14 and TSSOP-14 Packages



Package/Ordering Information

DEVICE	Package Type	MARKING	Packing	Packing Qty
AD8551M5/TR	SOT-23-5	8551	REEL	3000pcs/reel
AD8551M/TR	SOP-8	8551,AD8551	REEL	2500pcs/reel
AD8551MM/TR	MSOP-8	8551	REEL	3000pcs/reel
AD8551DQ3/TR	DFN-8 3*3	8551	REEL	5000pcs/reel
AD8552M/TR	SOP-8	8552,AD8552	REEL	2500pcs/reel
AD8552MM/TR	MSOP-8	8552	REEL	3000pcs/reel
AD8552DQ3/TR	DFN-8 3*3	8552	REEL	5000pcs/reel
AD8554M/TR	SOP-14	8554,AD8554	REEL	2500pcs/reel
AD8554MT/TR	TSSOP-14	8554,AD8554	REEL	2500pcs/reel

General Description

The AD855X amplifier is single/dual/quad supply, micro-power, zero-drift CMOS operational amplifiers, the amplifiers offer bandwidth of 1.8MHz, rail-to-rail inputs and outputs, and single-supply operation from 1.8V to 5.5V. AD855X uses chopper stabilized technique to provide very low offset voltage (less than 30 μ V maximum) and near zero drift over temperature. Low quiescent supply current of 180 μ A per amplifier and very low input bias current of 20pA make the devices an ideal choice for low offset, low power consumption and high impedance applications. The AD855X offers excellent CMRR without the crossover associated with traditional complementary input stages. This design results in superior performance for driving analog-to-digital converters (ADCs) without degradation of differential linearity.

The AD8551 is available in SOT23-5 、 DFN-8 MSOP-8 and SOP8 packages. And the AD8552 is available in MSOP8 、 DFN-8 and SOP8 packages. The AD8554 Quad is available in Green SOP14 and TSSOP14 packages. The extended temperature range of -40°C to +85°C over all supply voltages offers additional design flexibility.

Applications

- Transducer Application
- Temperature Measurements
- Electronics Scales
- Handheld Test Equipment
- Battery-Powered Instrumentatio

Pin Configuration

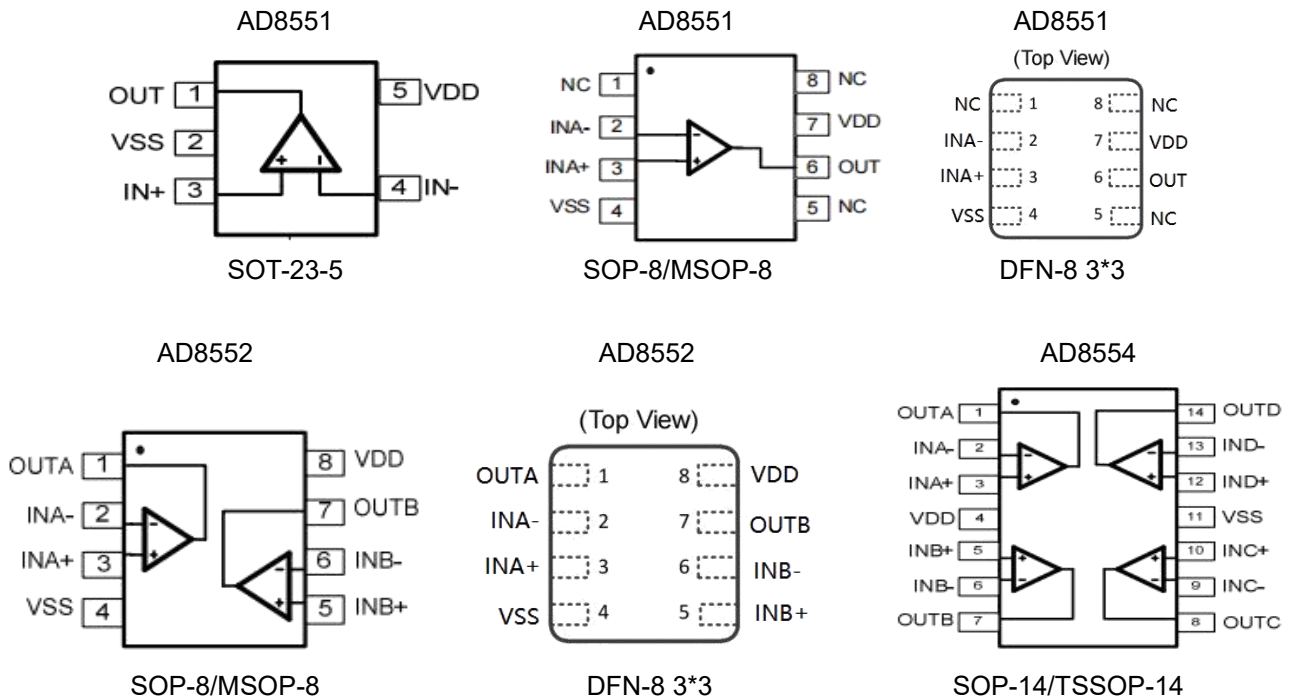

Figure 1. Pin Assignment Diagram

Absolute Maximum Ratings

Condition	Min	Max
Power Supply Voltage (V _{DD} to V _{SS})	-0.5V	+7.5V
Analog Input Voltage (IN+ or IN-)	V _{SS} -0.5V	V _{DD} +0.5V
PDB Input Voltage	V _{SS} -0.5V	+7V
Operating Temperature Range	-40°C	+85°C
Junction Temperature	+160°C	
Storage Temperature Range	-55°C	+150°C
Lead Temperature (soldering, 10sec)	+260°C	
Package Thermal Resistance (T_A=+25°C)		
SOP-8, θ_{JA}	125°C/W	
MSOP-8, θ_{JA}	216°C/W	
SOT23-5, θ_{JA}	190°C/W	
ESD Susceptibility		
HBM	6KV	
MM	400V	

Note: Stress greater than those listed under Absolute Maximum Ratings may cause permanent damage to the device. This is a stress rating only and functional operation of the device at these or any other conditions outside those indicated in the operational sections of this specification are not implied. Exposure to absolute maximum rating conditions for extended periods may affect reliability.

Electrical Characteristics

($V_S = +5V$, $V_{CM} = +2.5V$, $V_O = +2.5V$, $T_A = +25^\circ C$, unless otherwise noted.)

PARAMETER	CONDITIONS	MIN	TYP	MAX	UNITS
INPUT CHARACTERISTICS					
Input Offset Voltage (VOS)			1	30	μV
Input Bias Current (IB)			20		pA
Input Offset Current (IOS)			10		pA
Common-Mode Rejection Ratio(CMRR)	$V_{CM} = 0V$ to $5V$		110		dB
Large Signal Voltage Gain (AVO)	$R_L = 10k\Omega$, $V_O = 0.3V$ to $4.7V$		145		dB
Input Offset Voltage Drift ($\Delta V_{OS}/\Delta T$)			10	50	$nV/^\circ C$
OUTPUT CHARACTERISTICS					
Output Voltage High (VOH)	$R_L = 100k\Omega$ to $-V_S$		4.998		V
	$R_L = 10k\Omega$ to $-V_S$		4.994		V
Output Voltage Low (VOL)	$R_L = 100k\Omega$ to $+V_S$		2		mV
	$R_L = 10k\Omega$ to $+V_S$		5		mV
Short Circuit Limit (ISC)	$R_L = 10\Omega$ to $-V_S$		60		mA
Output Current (IO)			65		mA
POWER SUPPLY					
Power Supply Rejection Ratio (PSRR)	$V_S = 2.5V$ to $5.5V$		115		dB
Quiescent Current (IQ)	$V_O = 0V$, $R_L = 0\Omega$		180		μA
DYNAMIC PERFORMANCE					
Gain-Bandwidth Product (GBP)	$G = +100$		1.8		MHz
Slew Rate (SR)	$R_L = 10k\Omega$		0.95		$V/\mu s$
Overload Recovery Time			0.10		ms
NOISE PERFORMANCE					
Voltage Noise (en p-p)	0Hz to 10Hz		0.3		μV_{P-P}
Voltage Noise Density (en)	$f = 1kHz$		38		$nV\sqrt{Hz}$

Typical Performance characteristics

Large Signal Transient Response at +5V

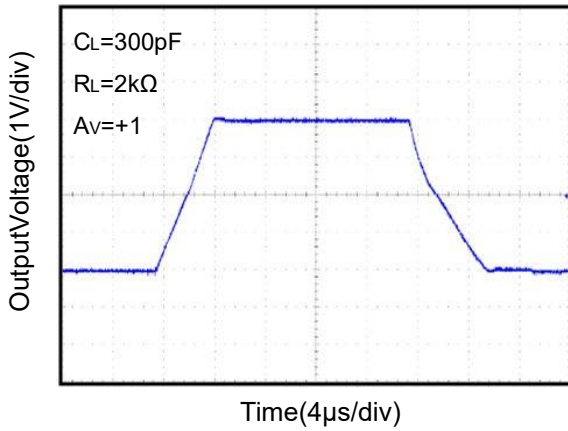

VLarge Signal Transient Response at+2.5V

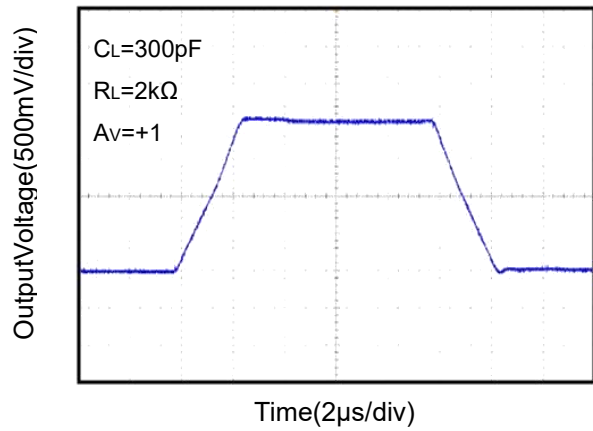

Small Signal Transient Response at +5V

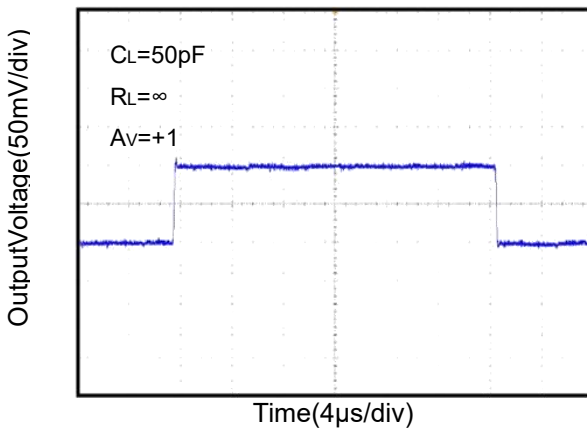

Small Signal Transient Response at +2.5V

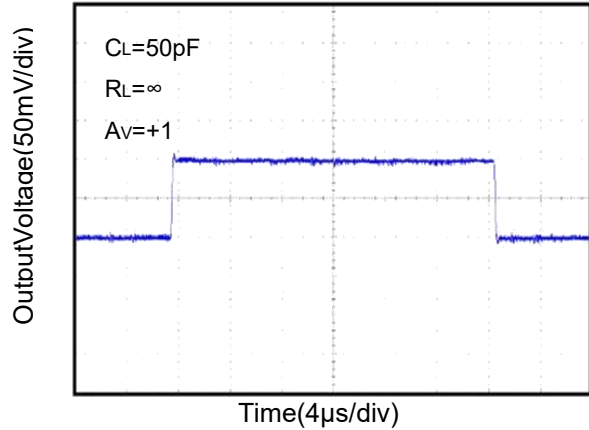

Closed Loop Gain vs. Frequency at +5V

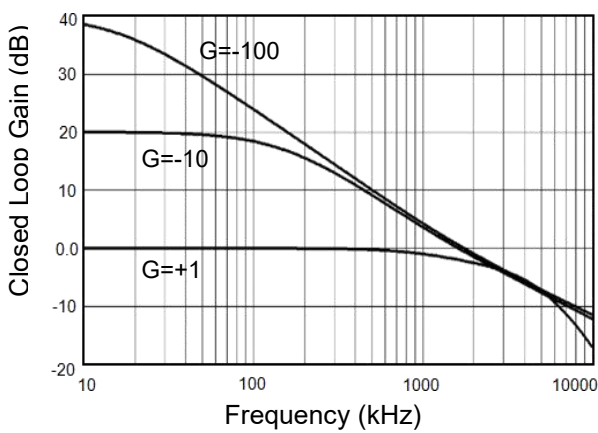

Closed Loop Gain vs. Frequency at +2.5V

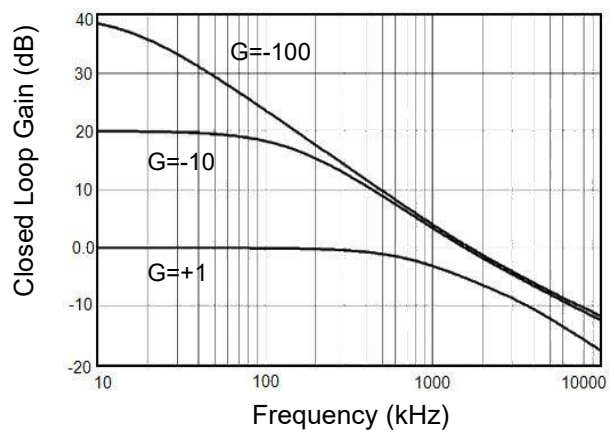

Typical Performance characteristics

Open Loop Gain, Phase Shift
vs. Frequency at +5V

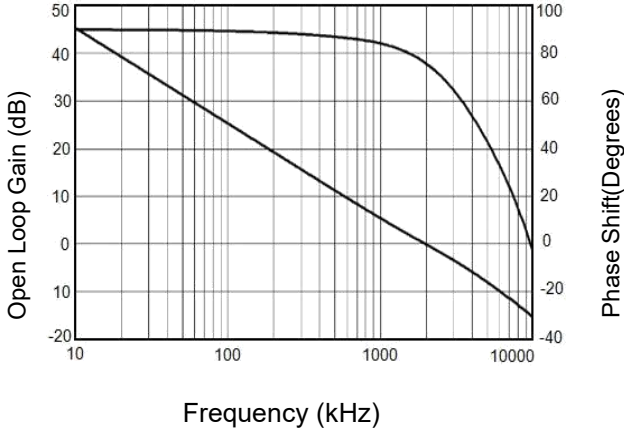

Open Loop Gain, Phase Shift
vs. Frequency at +2.5V

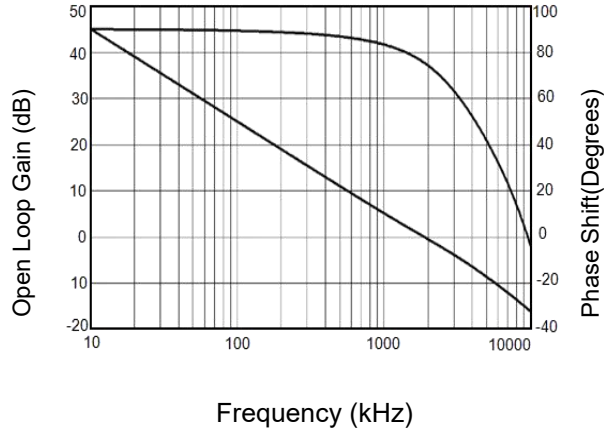

Positive Overvoltage Recovery

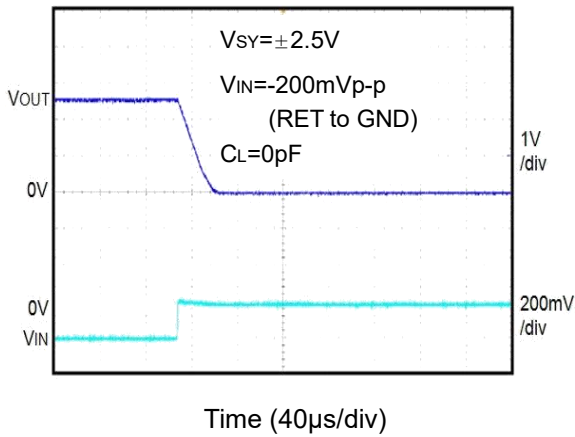

Negative Overvoltage Recovery

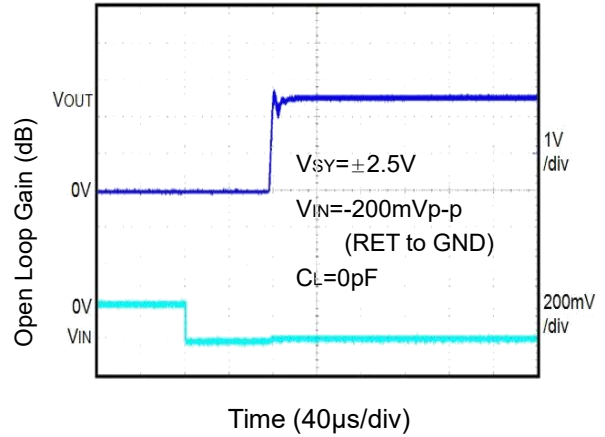

0.1Hz to 10Hz Noise at +5V

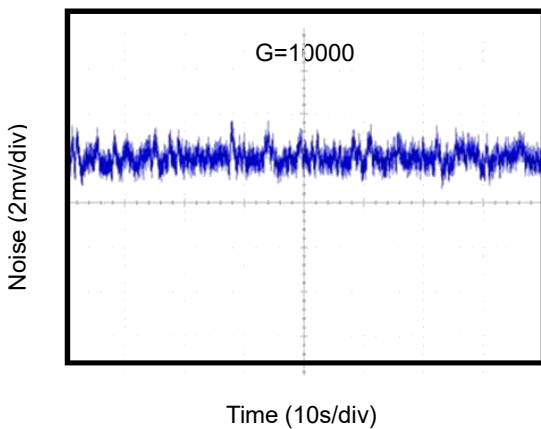

0.1Hz to 10Hz Noise at +2.5V

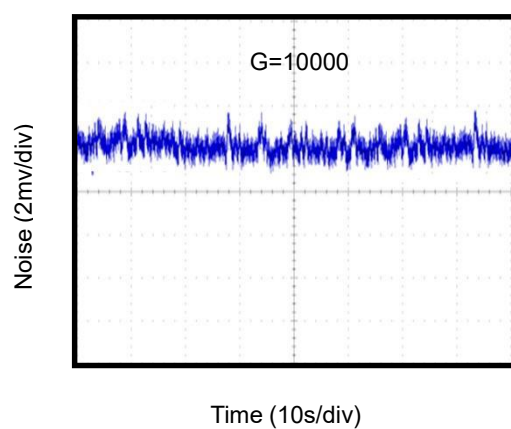

Application Note Size

AD855X series op amps are unity-gain stable and suitable for a wide range of general-purpose applications. The small footprints of the AD855X series packages save space on printed circuit boards and enable the design of smaller electronic products.

Power Supply Bypassing and Board Layout

AD855X series operates from a single 1.8V to 5.5V supply or dual $\pm 0.9V$ to $\pm 2.75V$ supplies. For best performance, a 0.1 μF ceramic capacitor should be placed close to the VDD pin in single supply operation. For dual supply operation, both VDD and VSS supplies should be bypassed to ground with separate 0.1 μF ceramic capacitors.

Low Supply Current

The low supply current (typical 180 μA per channel) of AD855X series will help to maximize battery life. They are ideal for battery powered systems.

Operating Voltage

AD855X series operate under wide input supply voltage (1.8V to 5.5V). In addition, all temperature specifications apply from $-40^{\circ}C$ to $+85^{\circ}C$. Most behavior remains unchanged throughout the full operating voltage range. These guarantees ensure operation throughout the single Li-Ion battery lifetime.

Rail-to-Rail Input

The input common-mode range of AD855X series extends 100mV beyond the supply rails ($VSS-0.1V$ to $VDD+0.1V$). This is achieved by using complementary input stage. For normal operation, inputs should be limited to this range.

Rail-to-Rail Output

Rail-to-Rail output swing provides maximum possible dynamic range at the output. This is particularly important when operating in low supply voltages. The output voltage of AD855X series can typically swing to less than 5mV from supply rail in light resistive loads ($>100k\Omega$), and 60mV of supply rail in moderate resistive loads (10k Ω).

Capacities Load Tolerance

The AD855x family is optimized for bandwidth and speed, not for driving capacitive loads. Output capacitance will create a pole in the amplifier's feedback path, leading to excessive peaking and potential oscillation. If dealing with load capacitance is a requirement of the application, the two strategies to consider are (1) using a small resistor in series with the amplifier's output and the load capacitance and (2) reducing the bandwidth of the amplifier's feedback loop by increasing the overall noise gain. Figure 2. shows a unity gain follower using the series resistor strategy. The resistor isolates the output from the capacitance and, more importantly, creates a zero in the feedback path that compensates for the pole created by the output capacitance.

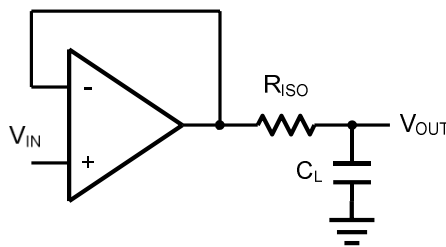

Figure 2. Indirectly Driving a Capacities Load Using Isolation Resistor

The bigger the RISO resistor value, the more stable VOUT will be. However, if there is a resistive load RL in parallel with the capacities load, a voltage divider (proportional to RISO/RL) is formed, this will result in a gain error.

The circuit in Figure 3 is an improvement to the one in Figure 2. RF provides the DC accuracy by feed-forward the VIN to RL. CF and RISO serve to counteract the loss of phase margin by feeding the high frequency component of the output signal back to the amplifier's inverting input, thereby preserving the phase margin in the overall feedback loop.

Capacities drive can be increased by increasing the value of CF. This in turn will slow down the pulse response.

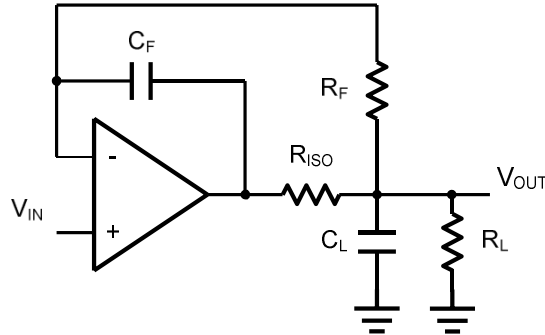

Figure 3. Indirectly Driving a Capacities Load with DC Accuracy

Typical Application Circuits

Differential amplifier

The differential amplifier allows the subtraction of two input voltages or cancellation of a signal common the two inputs. It is useful as a computational amplifier in making a differential to single-end conversion or in rejecting a common mode signal.

Figure 4. shown the differential amplifier using AD855X.

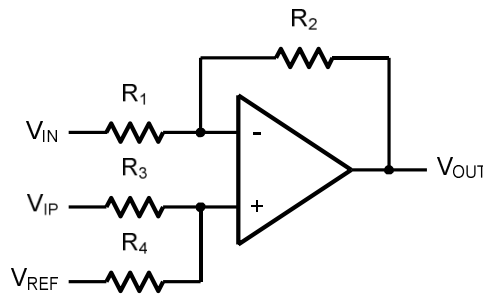

Figure 4. Differential Amplifier

$$V_{OUT} = \left(\frac{R_1 + R_2}{R_3 + R_4}\right) \frac{R_4}{R_1} V_{IN} - \frac{R_2}{R_1} V_{IP} + \left(\frac{R_1 + R_2}{R_3 + R_4}\right) \frac{R_3}{R_1} V_{REF}$$

f the resistor ratios are equal (i.e. R1=R3 and R2=R4), then

$$V_{OUT} = \frac{R_2}{R_1} (V_{IP} - V_{IN}) + V_{REF}$$

Low Pass Active Filter

The low pass active filter is shown in Figure 5. The DC gain is defined by $-R_2/R_1$. The filter has a -20dB/decade roll-off after its corner frequency $f_C=1/(2\pi R_3C_1)$.

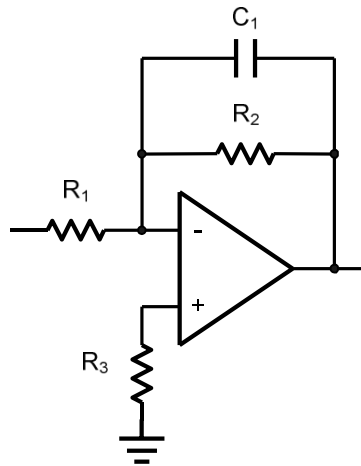

Figure 5. Low Pass Active Filte

Instrumentation Amplifier

The triple AD855X can be used to build a three-op-amp instrumentation amplifier as shown in Figure 6. The amplifier in Figure 6 is a high input impedance differential amplifier with gain of R_2/R_1 . The two differential voltage followers assure the high input impedance of the amplifier.

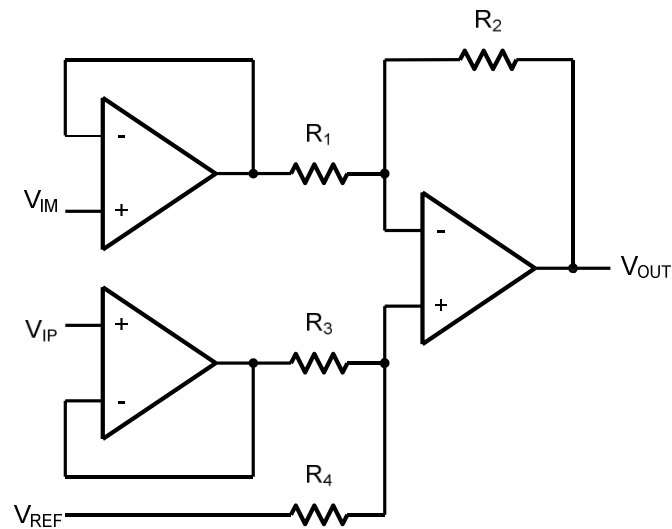
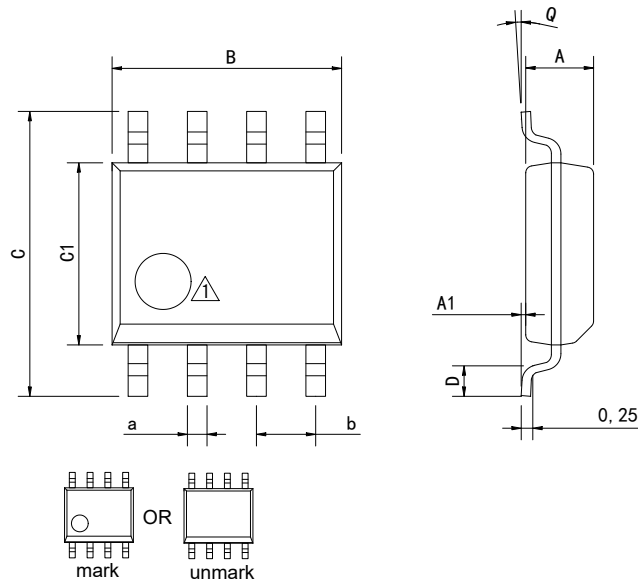

Figure 6. Instrument Amplifier

Package Information

SOP-8



⚠ Package top mark may be in lower left corner or unmark

Dimensions In Millimeters(SOP-8)									
Symbol:	A	A1	B	C	C1	D	Q	a	b
Min:	1.35	0.05	4.90	5.80	3.80	0.40	0°	0.35	1.27 BSC
Max:	1.55	0.20	5.10	6.20	4.00	0.80	8°	0.45	

MSOP-8

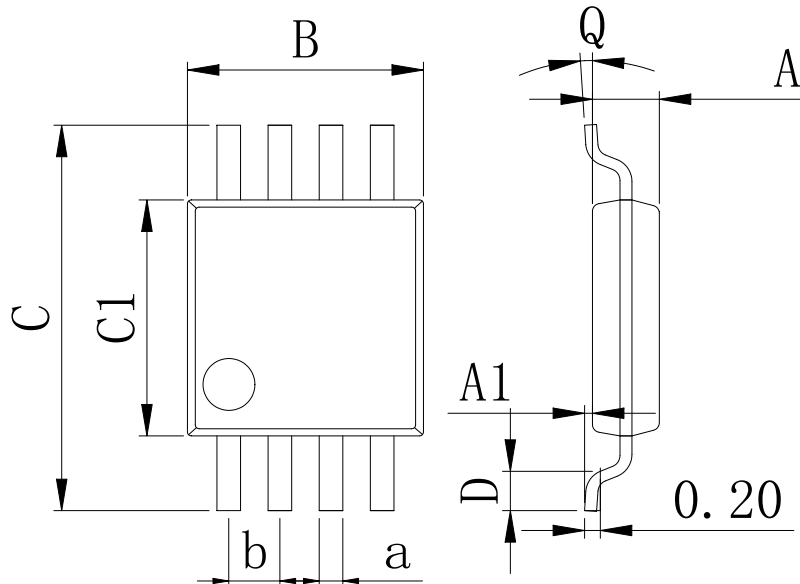

Dimensions In Millimeters(MSOP-8)									
Symbol:	A	A1	B	C	C1	D	Q	a	b
Min:	0.80	0.05	2.90	4.75	2.90	0.35	0°	0.25	0.65 BSC
Max:	0.90	0.20	3.10	5.05	3.10	0.75	8°	0.35	

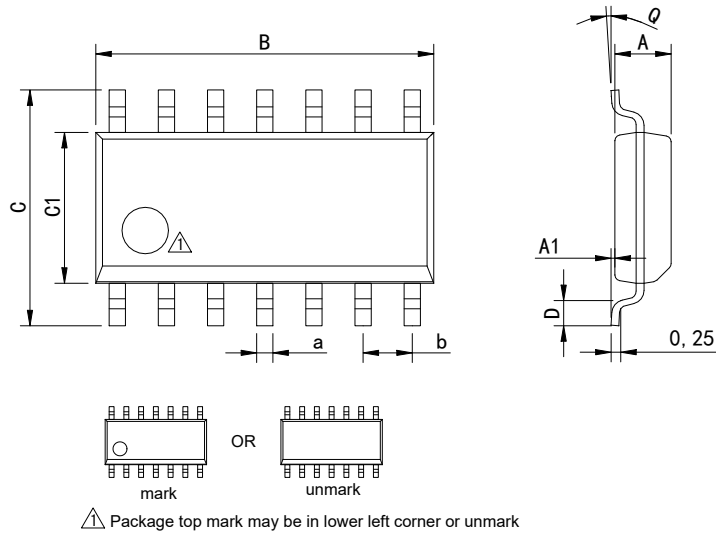
Package Information
SOP-14

Dimensions In Millimeters(SOP-14)									
Symbol:	A	A1	B	C	C1	D	Q	a	b
Min:	1.35	0.05	8.55	5.80	3.80	0.40	0°	0.35	1.27 BSC
Max:	1.55	0.20	8.75	6.20	4.00	0.80	8°	0.45	

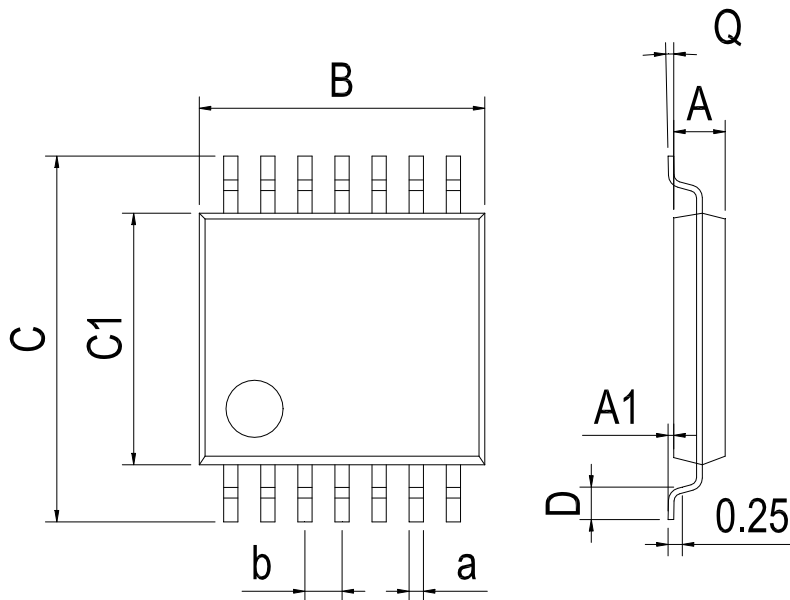
TSSOP-14

Dimensions In Millimeters(TSSOP-14)									
Symbol:	A	A1	B	C	C1	D	Q	a	b
Min:	0.85	0.05	4.90	6.20	4.30	0.40	0°	0.20	0.65 BSC
Max:	0.95	0.20	5.10	6.60	4.50	0.80	8°	0.25	

Package Information

SOT-23-5

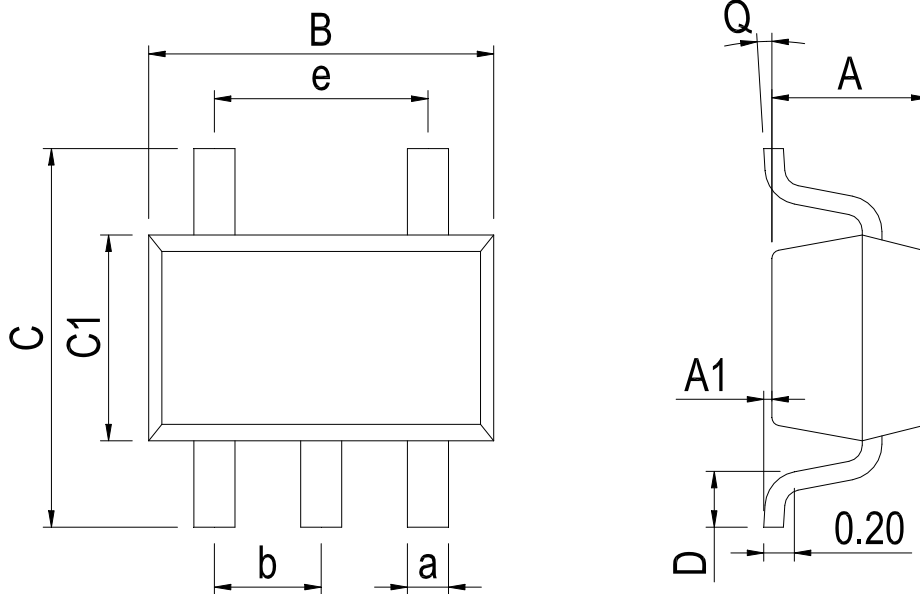

Dimensions In Millimeters(SOT-23-5)										
Symbol:	A	A1	B	C	C1	D	Q	a	b	e
Min:	1.00	0.00	2.82	2.65	1.50	0.30	0°	0.30	0.95 BSC	1.90 BSC
Max:	1.15	0.15	3.02	2.95	1.70	0.60	8°	0.50		

DFN-8 3*3

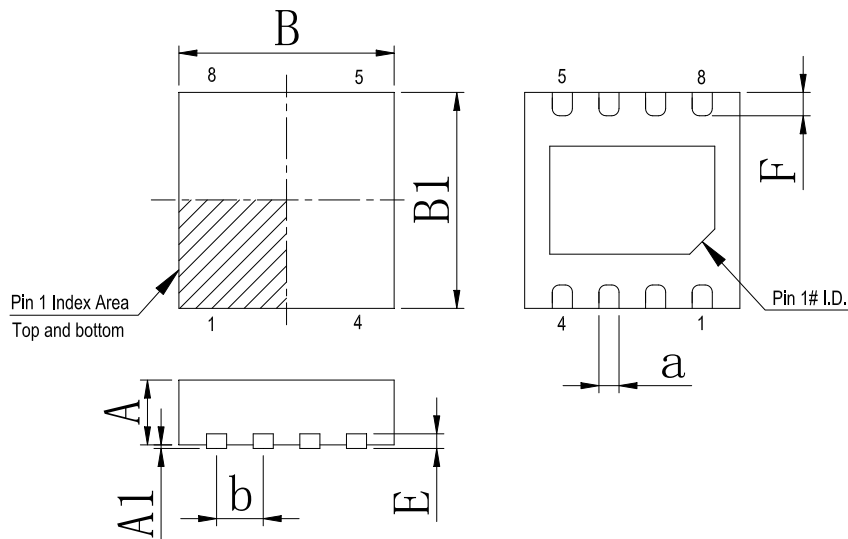

Dimensions In Millimeters(DFN-8 3*3)								
Symbol:	A	A1	B	B1	E	F	a	b
Min:	0.85	0.00	2.90	2.90	0.20	0.30	0.20	0.65 BSC
Max:	0.95	0.05	3.10	3.10	0.25	0.50	0.34	

Revision History

REVISION NUMBER	DATE	REVISION	PAGE
V1.0	2017-6	New	1-14
V1.1	2023-7	Update encapsulation type	2
V1.2	2024-11	Update SOT-23-5 Physical dimension、 Update Lead Temperature	3、 12
V1.3	2025-9	Update important statements、 Update SOP-8 and SOP-14 Dimension drawing	10、 11
V1.4	2025-10	Add the DFN-8 package device、	1

IMPORTANT STATEMENT:

Huaguan Semiconductor reserves the right to change products and services offered without prior notice. Customers should obtain the latest relevant information before placing orders and verify that such information is current and complete. Huaguan Semiconductor assumes no responsibility or liability for altered documents.

Customers are responsible for complying with safety standards and implementing safety measures when using Huaguan Semiconductor products in system design and end-product manufacturing. You assume full responsibility for: selecting the appropriate Huaguan Semiconductor products for your application; designing, validating, and testing your application; and ensuring that your application complies with applicable standards and all other safety, security, or other requirements. This is to prevent potential risks that may lead to personal injury or property damage.

Huaguan Semiconductor products are not approved for use in life support, military, aerospace, or other high-risk applications. Huaguan products are neither intended nor warranted for use in such systems or equipment. Any failure or malfunction may lead to personal injury or severe property damage. Such applications are deemed "Unsafe Use." Unsafe Use includes, but is not limited to: surgical and medical equipment, nuclear energy control equipment, aircraft or spacecraft instruments, control or operation of vehicle power, braking, or safety systems, traffic signal instruments, all types of safety devices, and any other applications intended to support or sustain life. Huaguan Semiconductor shall not be liable for consequences resulting from Unsafe Use in these fields. Users must independently evaluate and assume all risks. Any issues, liabilities, or losses arising from the use of products beyond their approved applications shall be solely borne by the user. Users may not claim any compensation from Huaguan Semiconductor based on these terms. If any third party claims against Huaguan Semiconductor due to such Unsafe Use, the user shall compensate Huaguan Semiconductor for all resulting damages and liabilities.

Huaguan Semiconductor provides technical and reliability data (including datasheets), design resources (including reference designs), application or other design advice, web tools, safety information, and other resources for its semiconductor products. However, no guarantee is made that these resources are free from defects, and no express or implied warranties are provided. The use of testing and other quality control techniques is limited to Huaguan Semiconductor's quality assurance scope. Not all parameters of each device are tested.

Huaguan Semiconductor's documentation authorizes you to use these resources only for developing applications related to the products described herein. You are not granted rights to any other intellectual property of Huaguan Semiconductor or any third party. Any other reproduction or display of these resources is strictly prohibited. You shall fully indemnify Huaguan Semiconductor and its agents against any claims, damages, costs, losses, and liabilities arising from your use of these resources. Huaguan Semiconductor shall not be held responsible.