

RoHS

VER	MARK	PR. BY	DESCRIPTION	DATE

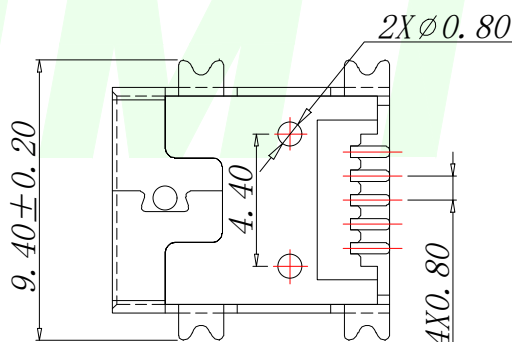
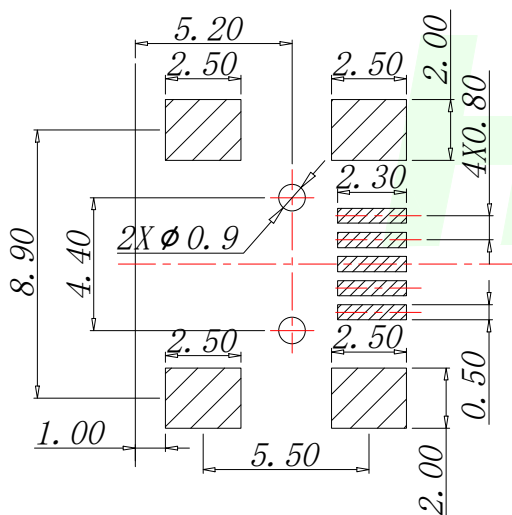
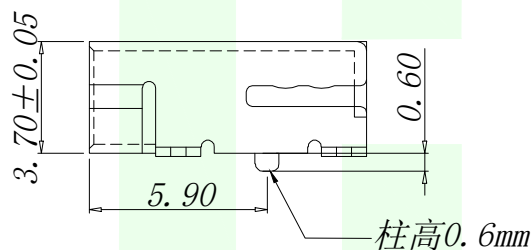
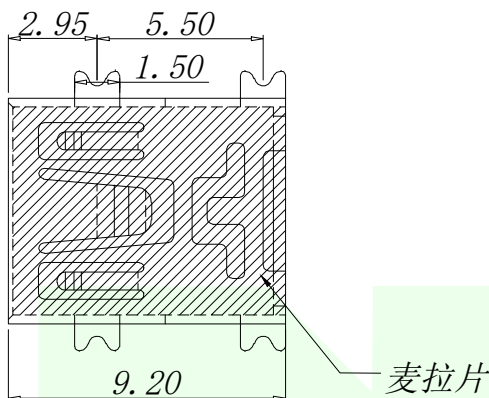
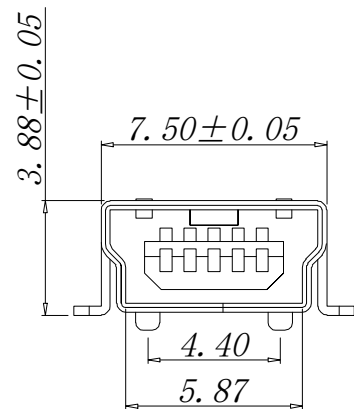

RECOMMENDED PCB LAYOUT  
GENERAL TOLERANCE ±0.05

规格说明: Specifications:

电气特性: Electrical:

1. 额定电流: Current Rating  
1.0A/contact terminal
2. 额定电压: Voltage Rating 30V DC
3. 接触阻抗: Contact Resistance 50 milliohms MAX
4. 耐电压: Dielectric Withstanding Voltage: 300 V AC AT Sea Level
5. 绝缘阻抗: Insulation Resistance: 100MEGA ohms MIN

原材料: Raw material:

1. 塑胶: Plastic cement:  
High Temperature Thermoplastics,  
LCP Black
2. 端子: Contact: Copper Alloy C2680/C5191
3. 外壳: Shell: SPCC/Copper Alloy C2680

电镀: Electroplate:

1. 端子: Contact: Plated Gold in Mating Area;  
Tin On Solder Talls
2. 外壳: Shell:  
Nickel Plating

GENERAL TOLERANCES UNLESS SPECIFIED		 <b>深圳市华明通电子有限公司</b> Shenzhen Huamingtong Electronics Co., Ltd	
X.X ±0.30	X.* ±5°	PART NO.	TITLE:
.XX ±0.20	X.X* ±1°	HMT-MINIUSB-5PTP	MINI USB 5P/F SMT
.XXX ±0.10	X.XX* ±0.5°	DESIGN: James	CUSTOMER
MANUFACTURE DWG		CHED: Talen	
		APPD: Sophia	UNITS MM
			SCALE
			N:A
			SHEET
			1/1