



钰地半导体  
Tudi Semiconductor

## Product Specification

TUDI-ULQ2001-4

七达林顿阵列

网址 [www.sztdbdt.com](http://www.sztdbdt.com) 🔍

**用芯智造 · 卓越品质**

**semiconductor device  
manufacturer**

- Design
- research and development
- production
- and sales



## 特点

- 每封装包含七个达林顿管
- 每通道输出电流500mA
- 输出电 集成续流二极管，适用于感性负载
- 输出可并联以获得更大电流
- 兼容TTL/CMOS/PMOS/DTL输入
- 输入引脚位于输出引脚对面，便于布局设计

## 说明

ULQ2001、ULQ2002、ULQ2003和ULQ2004是高压、大电流达林顿阵列，每个阵列包含七个共集电极的达林顿对。每个通道的额定电流为500mA，可承受600mA的峰值电流。内置抑制二极管用于驱动感性负载，且输入引脚与输出引脚位置相反，以简化电路板布局。

这些版本可与常见的逻辑系列接口：ULQ2001（通用、DTL、TTL、PMOS、CMOS）；ULQ2002（14-25V PMOS）；ULQ2003（5V TTL、CMOS）；ULQ2004（6-15V CMOMOS）。

ULQ2001A/2002A/2003A和2004A提供16引脚DIP封装和16引脚SOP封装

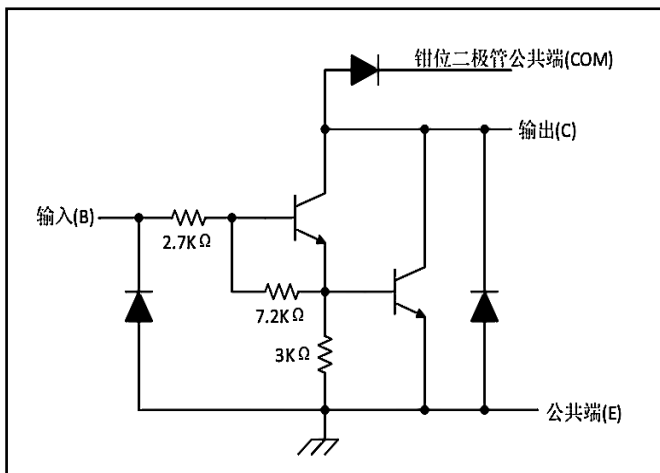
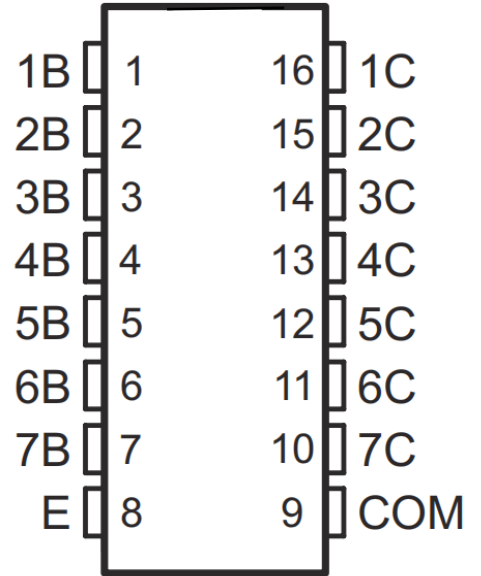

单路驱动电路原理图

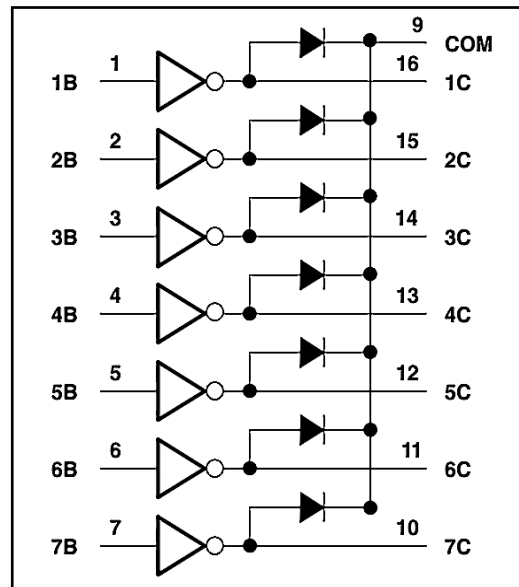

简化版方框图

## 应用

- 继电器驱动器 ● 灯驱动器 ● 显示屏驱动器 ● 线路驱动器 ● 逻辑缓冲器



## 引脚功能

引脚		I/O(1)	说明
名称	编号		
1B	1	I	达林顿基极输入
2B	2	I	达林顿基极输入
3B	3	I	达林顿基极输入
4B	4	I	达林顿基极输入
5B	5	I	达林顿基极输入
6B	6	I	达林顿基极输入
7B	7	I	达林顿基极输入
E	8	—	所有通道共享的共发射极(通常与地面相连)
COM	9	—	反激二极管的共阴极节点(用于感性负载)
7C	10	O	达林顿集电极输出
6C	11	O	达林顿集电极输出
5C	12	O	达林顿集电极输出
4C	13	O	达林顿集电极输出
3C	14	O	达林顿集电极输出
2C	15	O	达林顿集电极输出
1C	16	O	达林顿集电极输出

## 极限参数

极限参数	
存储温度:	65°C~150°C
工作温度范围:	-40°C to 105°C
结温度范围:	40°C~150°C
输入电压:	0.3V~30V
输出电压:	55V
射极到基极的最高耐压:	6.0V
集电极持续工作电流:	500mA
基极持续工作电流:	25mA



## 电参数

参数	测试图	测试条件		2001/2003		2004		单位
				最小值	典型值	最大值	最小值	
Vi(on) 导通状态输入电压	图6	VCE=2V		lc=125mA			5	V
				lc=200mA	2.4		6	
				lc=250mA	2.7			
				lc=275mA			7	
				lc=300mA	3			
				lc=350mA			8	
VOH 开关后高电平输出电压	图10	Vs=50V, lo=300mA		Vs -20		Vs -20		mV
VCE(sat) 集电极-发射极饱和电压	图5	I=250μA, lc=100mA		0.9	1.1	0.9	1.1	V
		I=350μA, lc=200mA		1	1.3	1	1.3	
		I=500μA, lc=350mA		1.2	1.6	1.2	1.6	
CEX 集电极截止电流	图1	VCE=50V, I=0		50		50		μA
	图2	VCE=50V, TA=70°C	I=0 Vi=6V	100		100		
VF 钳位正向电压	图8	IF=350mA		1.7	2	1.7	2	V
I(off) 关断状态输入电流	图3	VCE=50V, TA=70°C	lc=500μA	50	65	50	65	μA
I 输入电流	图4	V=3.85V		0.93		1.35		mA
		V=5V				0.35 0.5		
		V=12V				1 1.45		
IR 钳位反向电流	图7	VR=50V		50		50		μA
		VR=50V	TA=70°C	100		100		
Ci 输入电容		Vi=0,	f=1MHz	15	25	15	25	pF

参数	测试图	测试条件		2002		单位
				最小值	典型值	
Vi(on) 导通状态输入电压	图6	VCE=2V, lc=300mA		13		V
VOH 开关后高电平输出电压	图10	Vs=50V, lo=300mA		Vs -20		mV
VCE(sat) 集电极-发射极饱和电压	图4	I=250μA, lc=100mA		0.9	1.1	V
		I=350μA, lc=200mA		1	1.3	
		I=500μA, lc=350mA		1.2	1.6	
VF 钳位正向电压	图7	IF=350mA		1.7	2	V
CEX 集电极截止电流	图1	VCE=50V, I=0		50		μA
	图2	VCE=50V, TA=70°C	I=0 V=6V	100		
I(off) 关断状态输入电流	图2	VCE=50V,	c=500μA	50	65	μA
I 输入电流	图3	Vi=17V		0.82	1.25	mA
IR 钳位反向电流	图6	VR=50V	TA=70°C	100		μA
		VR=50V		50		
C 输入电容		Vi=0,	f=1MHz	25		pF

( 除非特殊说明 : V + = 5V , Ta = 25 )



## 开关特性

参数	测试条件	2001/2002/2003/2004		单位
		最小值	典型值	
t <sub>pLH</sub> 传播延迟时间, 低电平到高电平输出	请参阅图9	0.25	1	μS
t <sub>pHL</sub> 传播延迟时间, 高电平到低电平输出	请参阅图9	0.25	1	μS

## 电路测试

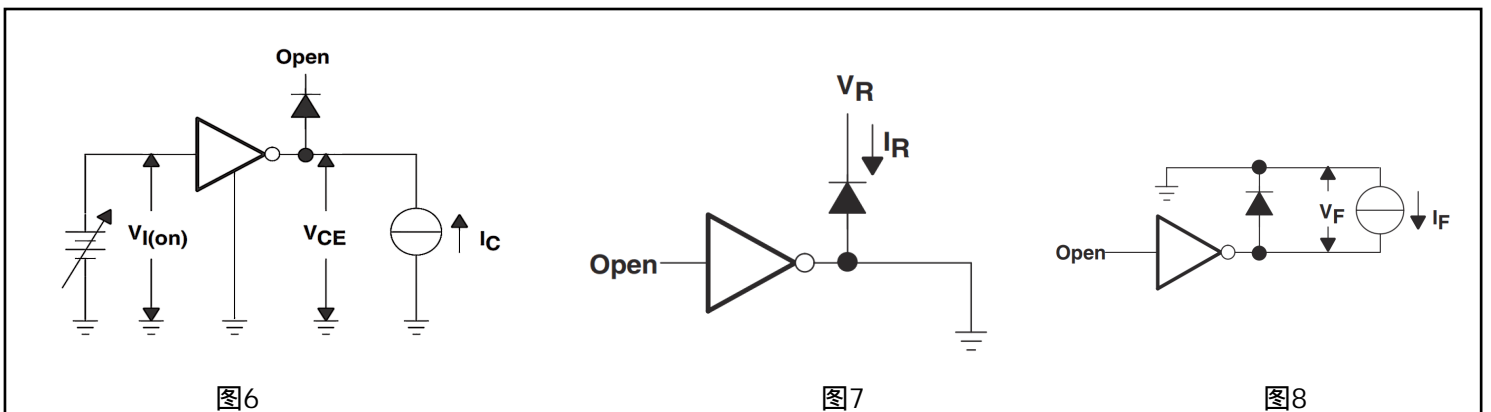
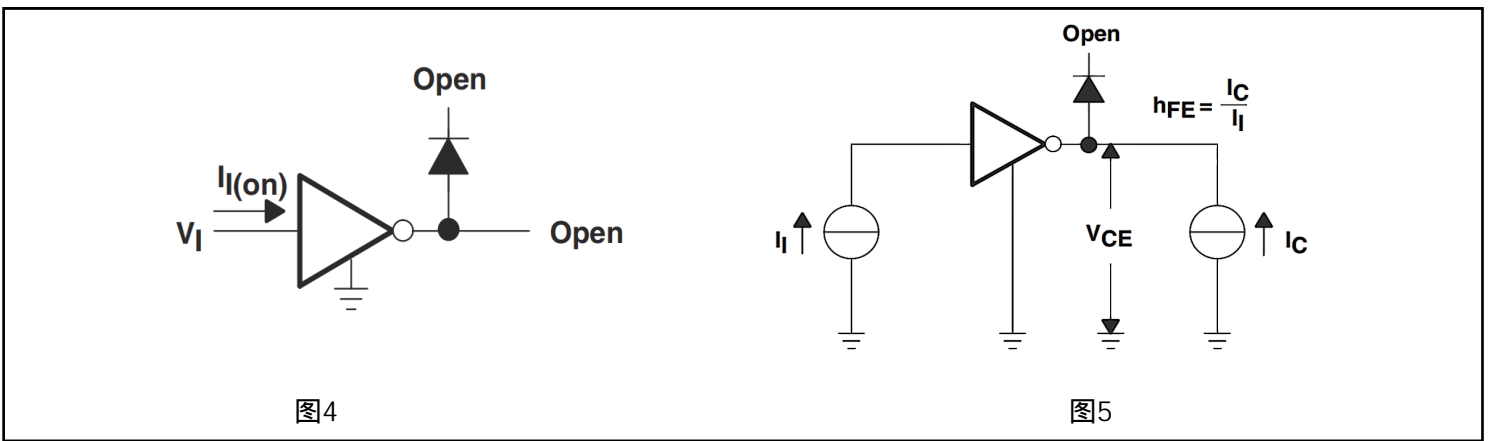
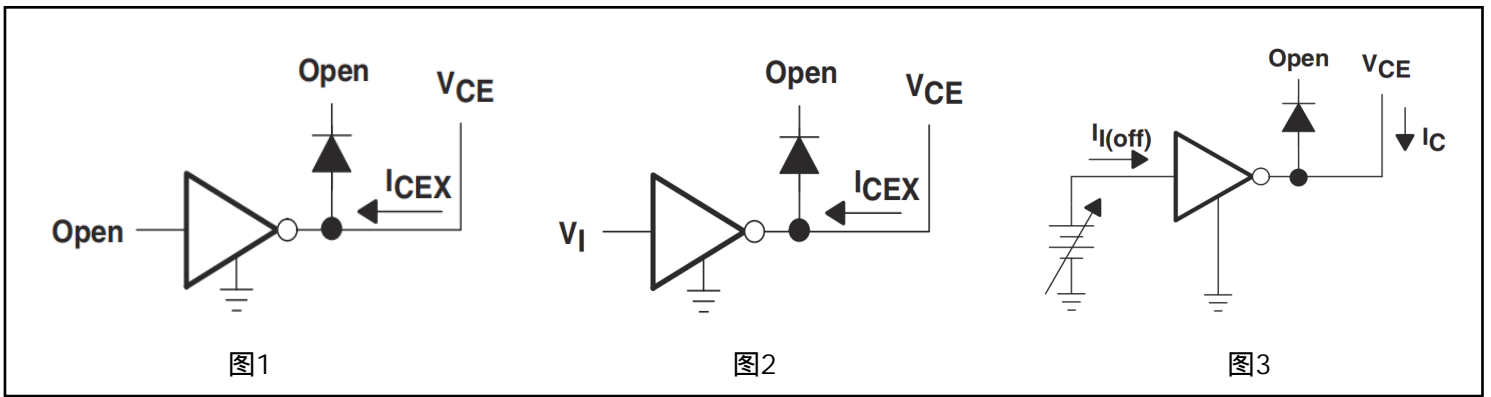

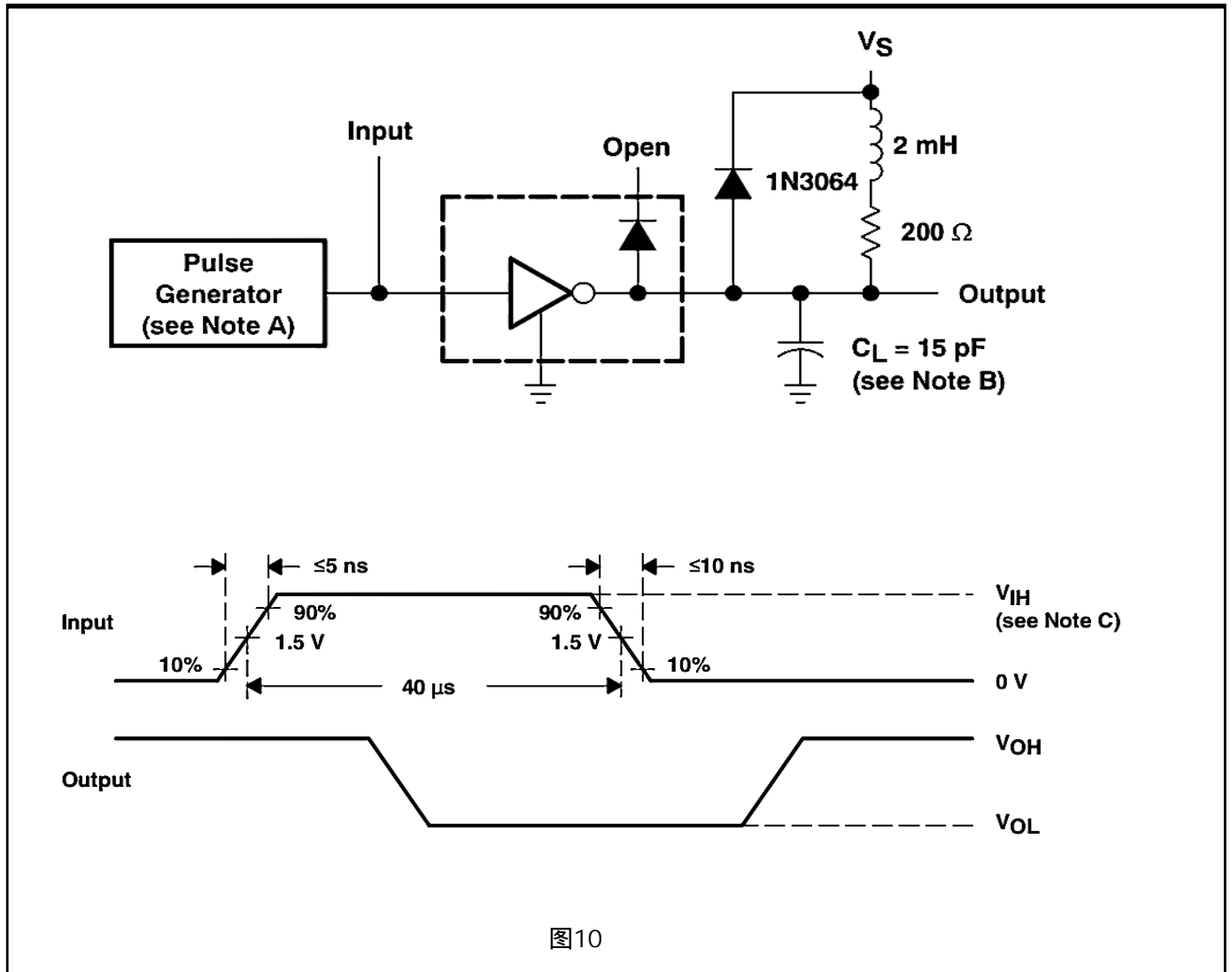
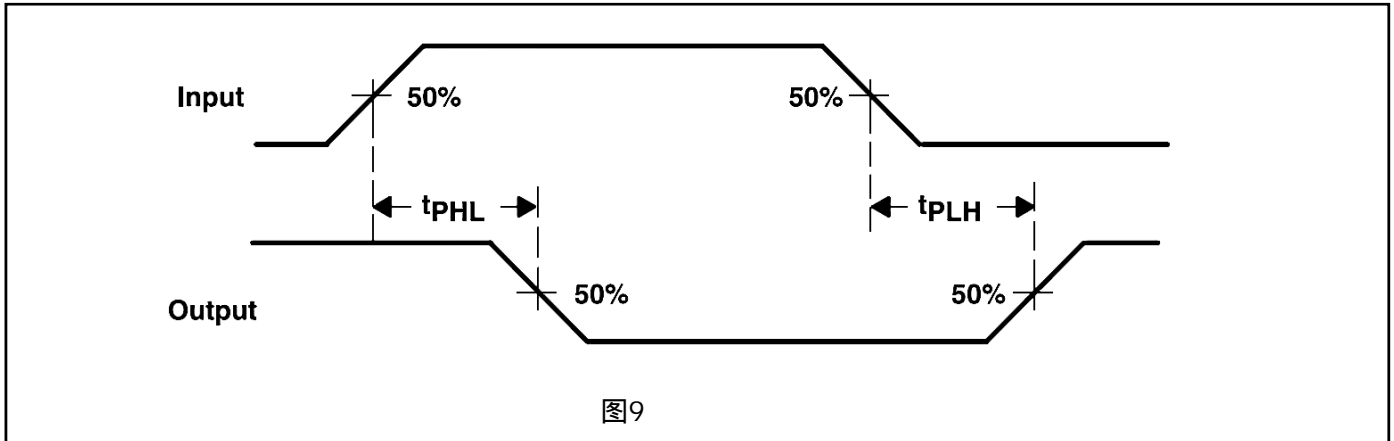

- 注：1、极限值是指超出该范围，器件有可能被损坏，并非器件的正常工作条件范围。电参数表提供了器件的工作条件范围；  
2、除特别指明外，所有条件适用于达林顿阵列；  
3、通常条件下，每路输出在  $70^{\circ}\text{C}$ 、 $V^{CE(Sat)} = 1.6\text{V}$  下脉冲宽度为 20ms 的持续工作



Package SOP16

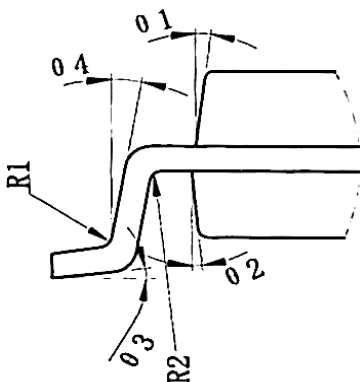
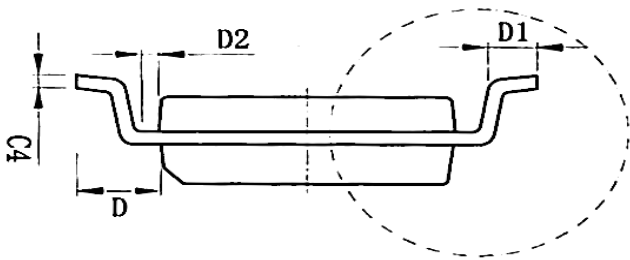
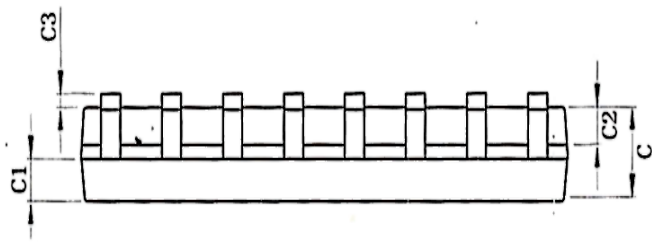
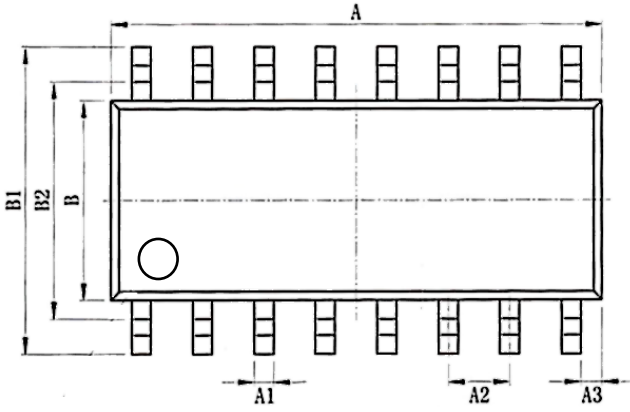

SIZE SYMBOL	MIN./mm	MAX./mm
A	9.80	10.00
A1	0.356	0.456
A2	1.27TYP	
A3	0.302TYP	
B	3.85	3.95
B1	5.84	6.24
B2	5.00 TYP	
C	1.40	1.60
C1	0.61	0.71
C2	0.54	0.64
C3	0.05	0.25
C4	0.203	0.233
D	1.05 TYP	
D1	0.40	0.70
D2	0.15	0.25
R1	0.20TYP	
R2	0.20TYP	
01	8°~12°TYP4	
02	8°~12°TYP4	
03	0°~8°	
04	4°~12°	



Package DIP16

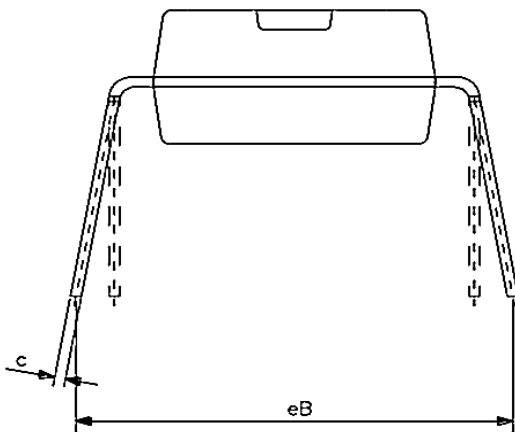
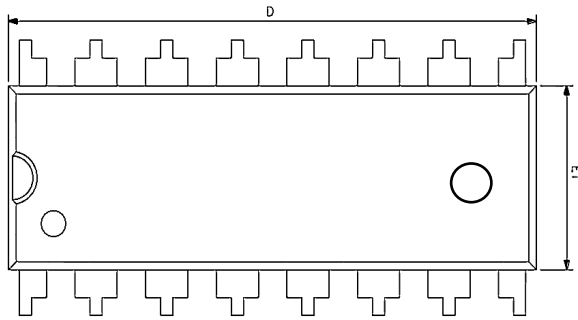
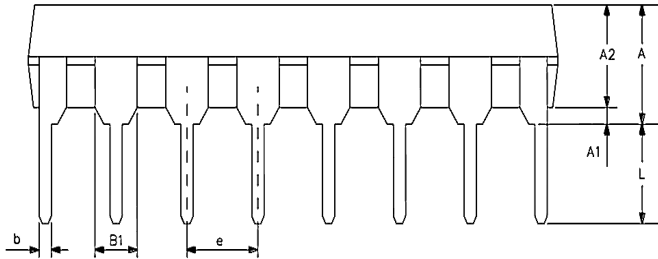

SIZE SYMBOL	MIN./mm	MAX./mm
A2	3.20	3.60
A1	0.51	—
A	3.60	5.33
L	3.00	3.60
b	0.36	0.56
B1	1.52	
D	18.80	19.94
E1	6.20	6.60
e	2.54	
C	0.20	0.36
eB	7.62	9.30
R	0.20TYP	
R1	0.30TYP	
$\theta$	0°	8°
$\theta_1$	45°TYP	
$\theta_2$	12°TYP	
$\theta_3$	0°	8°
$\theta_4$	0°	10°



## 订购信息

Order Number	Package	Package Quantity	Marking On The park	Temperature
ULQ2001A-TUDI	DIP16	Tube,25,A box of 1000	ULQ2001A	-40°C to 105°C
ULQ2003A-TUDI	DIP16	Tube,25,A box of 1000	ULQ2003A	
ULQ2004A-TUDI	DIP16	Tube,25,A box of 1000	ULQ2004A	
ULQ2003D1013TR-TUDI	SOP16	Tape,Reel,2500	ULQ2003	
ULQ2003D1013TRY-TUDI	SOP16	Tape,Reel,2500	ULQ2003Y	
ULQ2004D1013TR-TUDI	SOP16	Tape,Reel,2500	ULQ2004	



## Important statement:

- TUDI Semiconductor reserves the right to modify the product manual without prior notice! Before placing an order, customers need to confirm whether the obtained information is the latest version and verify the completeness of the relevant information.
- Any semi-guide product is subject to failure or malfunction under specified conditions. It is the buyer's responsibility to comply with safety standards when using TUDI Semiconductor products for system design and whole machine manufacturing. And take the appropriate safety measures to avoid the potential in the risk of loss of personal injury or loss of property situation!
- TUDI Semiconductor products have not been licensed for life support, military, and aerospace applications, and therefore TUDI Semiconductor is not responsible for any consequences arising from the use of this product in these areas.
- If any or all TUDI Semiconductor products (including technical data, services) described or contained in this document are subject to any applicable local export control laws and regulations, they may not be exported without an export license from the relevant authorities in accordance with such laws.
- The specifications of any and all TUDI Semiconductor products described or contained in this document specify the performance, characteristics, and functionality of said products in their standalone state, but do not guarantee the performance, characteristics, and functionality of said products installed in Customer's products or equipment. In order to verify symptoms and conditions that cannot be evaluated in a standalone device, the Customer should ultimately evaluate and test the device installed in the Customer's product device.
- TUDI Semiconductor documentation is only allowed to be copied without any alteration of the content and with the relevant authorization. TUDI Semiconductor assumes no responsibility or liability for altered documents.
- TUDI Semiconductor is committed to becoming the preferred semiconductor brand for customers, and TUDI Semiconductor will strive to provide customers with better performance and better quality products.