



钜地半导体
Tudi Semiconductor

Product Specification

TUDI-TPS2811/2812/2813

Dual High-Speed 2A MOSFET Drivers

网址 www.sztdbdt.com Q

用芯智造 · 卓越品质

semiconductor device
manufacturer

- Design
- research and development
- production
- and sales



Features

- High Peak Output Current: 2A
- Wide Supply Voltage Operating Range: 4V to 25V
- High Capacitive Load Drive Capability 1000pF in 11ns (typical)
- Short Delay Times: 35ns (typical)
- Matched Rise/Fall Times
- Low Output Impedance
- Low Supply Current
- Over-temperature Protection
- Under-voltage Lockout
- Non-overlapped Drive Tech
- ESD Protected: 2.0kV
- Input withstands negative inputs up to 5V
- Available in Green SOP8 and DIP8

Applications

- Wireless Power Transmitter
- Switch Mode Power Supplies
- Power MOSFET Drivers
- Pulse Transformer Drivers
- Line Drivers
- CCD Driver
- Class D Switching Amplifiers

Description

The TPS2811/2812/2813 are matched dual power MOSFET drivers. Unique circuit design enables high speed operation capable of delivering peak currents of 2A into 1000pF capacitive loads.

Improved speed and drive capability are enhanced by matched rise and fall delay times. These matched delays maintain the integrity of input-to-output pulse-widths to reduce timing errors and clockskew problems. Dynamic switching losses are minimized with non-overlapped drive techniques. These devices are highly latch-up resistant within their power and voltage ratings. They are not subject to damage when up to 5V of noise spiking (of either polarity) occurs on the ground pin. All terminals are fully protected against Electrostatic Discharge (ESD) up to 2.0 kV.

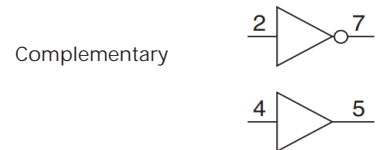
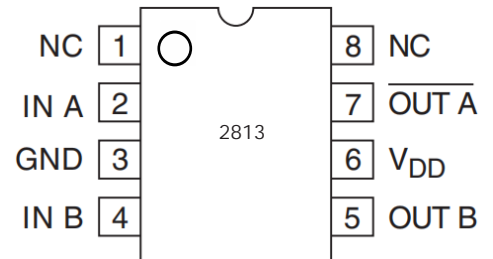
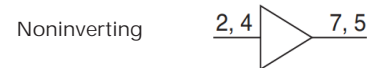
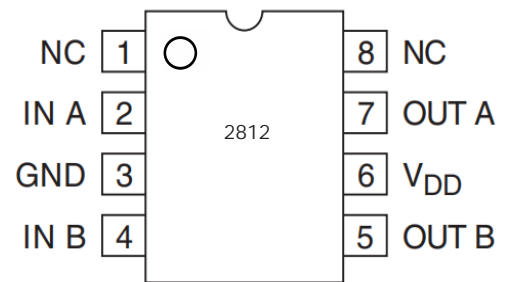
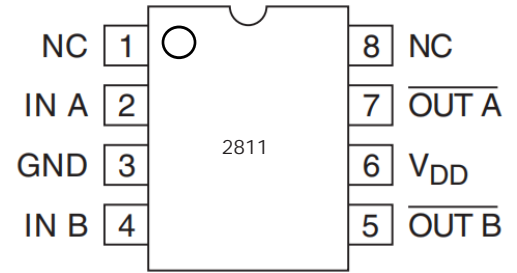



Pin Description

Pin	Name	Description
1	NC	No connection
2	IN A	Input A
3	GND	Ground
4	In B	Input B
5	OUT B	Output of Channel B
6	VDD	Power Supply
7	OUTA	Output of Channel A
8	NC	No connection
-	PAD	Exposed Metal Pad

Function Table

		TPS2811		TPS2812		TPS2813	
INA	INB	OUTA	OUT B	OUTA	OUTB	OUTA	OUTB
L	L	H	H	L	L	H	L
L	H	H	L	L	H	H	H
H	L	L	H	H	L	L	L
H	H	L	L	H	H	L	H

Thermal Data

Parameter	Rating	Unit
Package Thermal Resistance	155(SOP8) 90(DIP8)	°CW



Functional Block Diagram

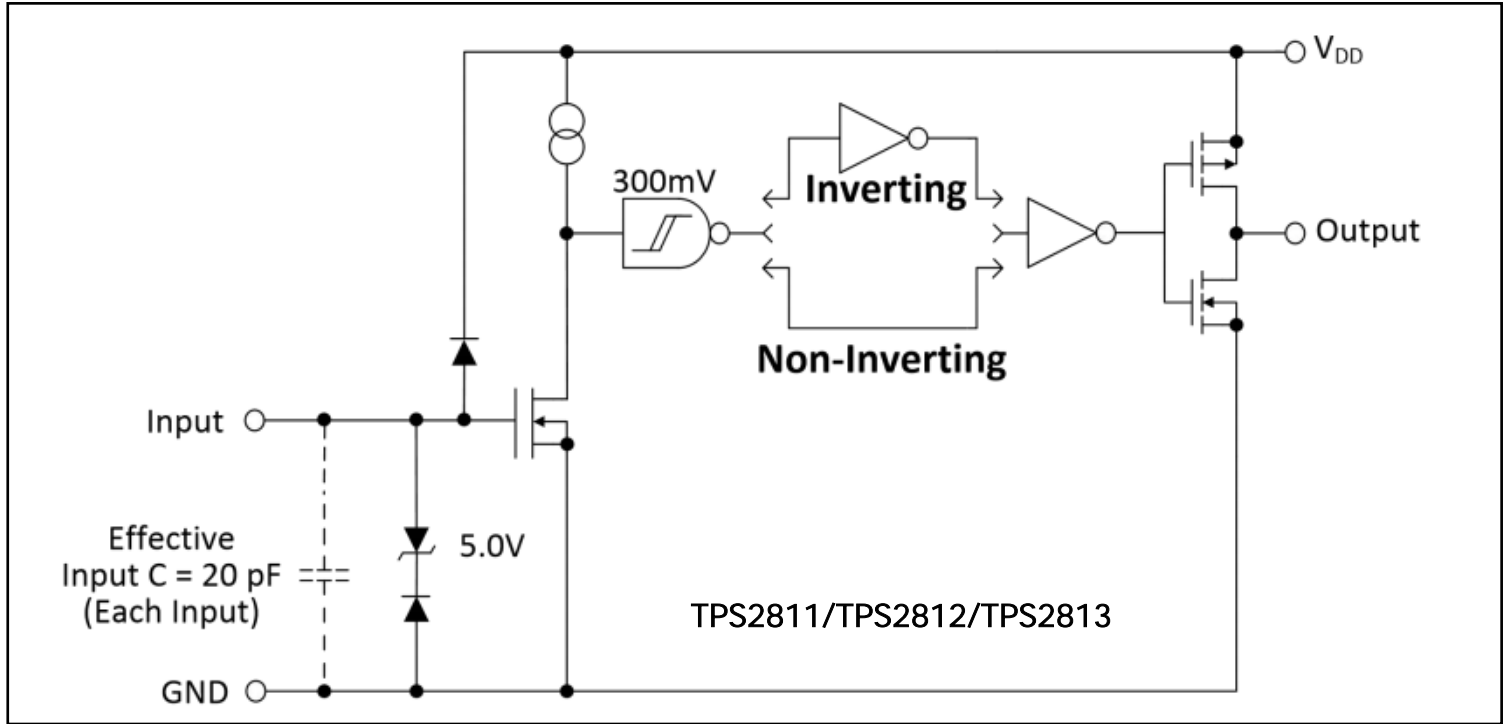

Note

1: TPS2811 has two inverting drivers, while the TPS2812 has two non-inverting drivers. The TPS2813 has one inverting and one non-inverting driver.

2: Ground any unused driver input.

Absolute Maximum Ratings

Parameter	Min	Max	Unit
DC supply voltage V_s		26	V
Operating junction temperature	-40	125	
Storage temperature	-55	150	
Maximum input voltage	GND-5	VDD+0.3	V
Combined peak output current		2	A

Note: Stresses exceeding the absolute maximum ratings may damage the device. The device may not function or be operable above the recommended operating conditions and stressing the parts to these levels is not recommended. In addition, extended exposure to stresses above the recommended operating conditions may affect device reliability. The absolute maximum ratings are stress ratings only.



Recommended Operating Conditions

Parameter	Rating	Unit
DC Supply Voltage	4-25	V
Operating ambient temperature	-40~125	°C

Additional description

Output A and B
MOSFET driver outputs A and B are low-impedance, CMOS push-pull style outputs. The pull-down and pullup devices are of equal strength, making the rise and fall times equivalent.
Inputs A and B
MOSFET driver inputs A and B are high-impedance, TTL/CMOS compatible inputs. These inputs also have 300 mV of hysteresis between the high and low thresholds that prevents output glitching even when the rise and fall time of the input signal is very slow.
Supply Input (VDD)
The VDD input is the bias supply for the MOSFET driver and is rated for 4V to 25V with respect to the Ground pin. The VDD input should be bypassed with local ceramic capacitors. The value of these capacitors should be chosen based on the capacitive load that is being driven. A value of 1.0µF is suggested.
Ground(GND)
Ground is the device return pin. The Ground pin(s) should have a low-impedance connection to the bias supply source return. High peak current flows out the Ground pin(s) when the capacitive load is being discharged.
Exposed Metal Pad
The exposed metal pad of the DFN-8 package is not internally connected to any potential. Therefore, this pad can be connected to a ground plane or other copper plane on a Printed Circuit Board (PCB), to aid in heat removal from the package.



Electrical Characteristics

(Typical values are tested at $T_a=25^\circ\text{C}$, $V_{DD}=18\text{V}$)

Parameter	Symbol	Conditions	Min.	Typ.	Max.	Unit
Input						
Input Signal High Threshold	V_{IH}		1.8			V
Input Signal Low Threshold	V_{IL}				0.7	V
Input Signal Hysteresis	V_{HYS}			0.3		V
Input Current	I_{in}	OV V_{In} VDD			± 1	μA
Output						
Pull-Up Resistance	R_{oH}	Source Current = 10mA		2.0		
Pull-Down Resistance	R_{oL}	Sink Current = -10mA		2.0		
Peak Output Current	I_{pk}	Source Current, $f=1\text{kHz}$, $CL=1000\text{pF}$		2		A
		Sink Current, $f=1\text{kHz}$, $CL=1000\text{pF}$		2		
Continuous Output Current	I_{oc}	Source /Sink Current		± 200		mA
Power supply Current						
Power Supply Current	I_{cc}	$V_{INA}=V_{INB}=3\text{V}$		0.9		mA
		$V_{INA}=V_{INB}=0\text{V}$		0.5		
Operating Voltage Range	VDD		4		25	V
Under-Voltage Lockout ONThreshold				3.6	4	V
Under-Voltage LockoutHysteresis				0.5		V
Switching characteristics						
Rise Time	t_R	$CL=1000\text{pF}$		11		ns
Fall Time	t_F	$CL=1000\text{pF}$		11		ns
Turn-On Delay Time	t_{D1}	Non-inverting Input		34		ns
		Inverting Input		44		ns
Turn-Off Delay Time	t_{D2}	Non-inverting Input		34		ns
		Inverting Input		44		ns
Over-temperature protection						
Thermal Shutdown Threshold				150		
Thermal Shutdown ThresholdHysteresis				25		



Switching Time Test Circuit

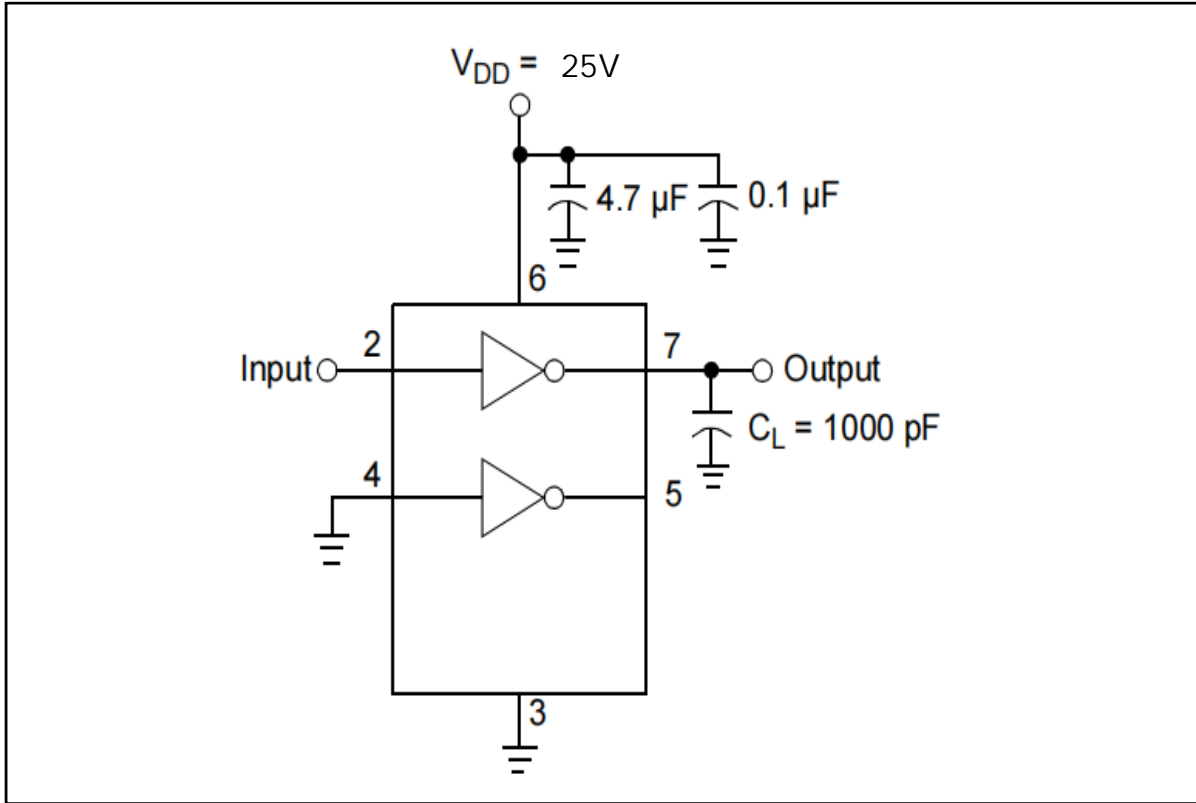

Inverting Driver

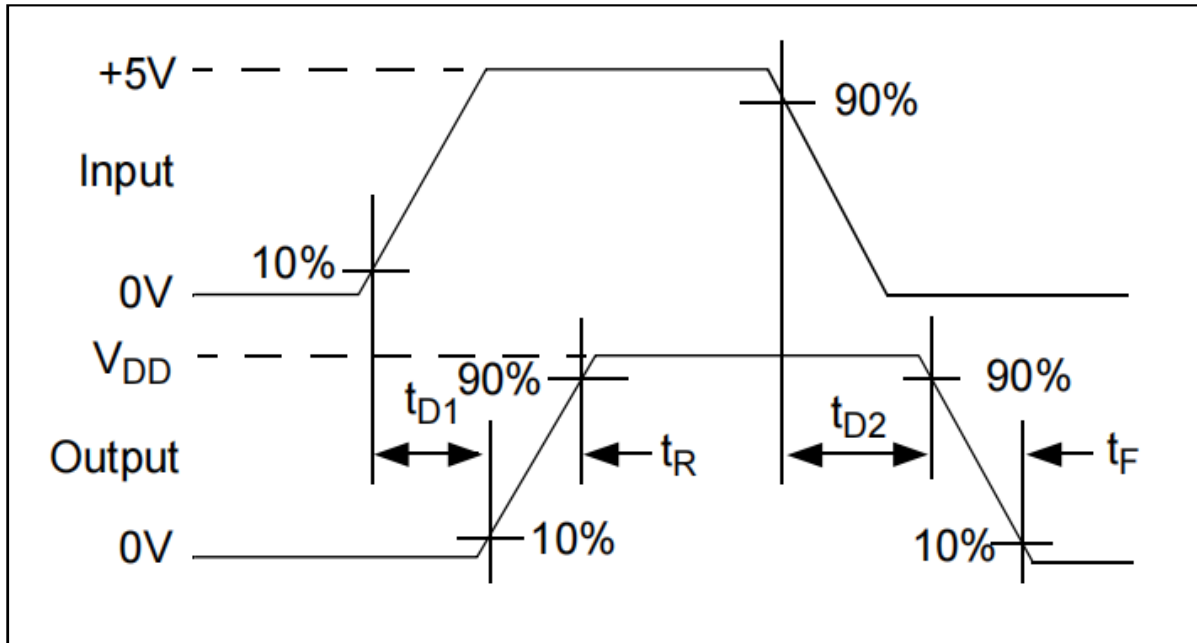

Non-Inverting Driver

Order information

Order Number	Package	Package Quantity	Marking On The park	Temperature
TPS2811DR-TUDI	SOP8	Tape,Reel,2500	2811	-40°C to 125°C
TPS2811P-TUDI	DIP8	Tube,50,A box of 2000	TPS2811P	
TPS2812DR-TUDI	SOP8	Tape,Reel,2500	2812	
TPS2812P-TUDI	DIP8	Tube,50,A box of 2000	TPS2812P	
TPS2813DR-TUDI	SOP8	Tape,Reel,2500	2813	
TPS2813P-TUDI	DIP8	Tube,50,A box of 2000	TPS2813P	



Package SOP8



Symbol	Dimensions In Millimeters		Dimensions In Inches	
	Min	Max	Min	Max
A	1.350	1.750	0.053	0.069
A1	0.100	0.250	0.004	0.010
A2	1.350	1.550	0.053	0.061
B	0.330	0.510	0.013	0.020
C	0.190	0.250	0.007	0.010
D	4.780	5.000	0.188	0.197
E	3.800	4.000	0.150	0.157
E1	5.800	6.300	0.228	0.248
e	1.270TYP		0.050TYP	
L	0.400	1.270	0.016	0.050
theta	0°	8°	0°	8°





Package DIP8



Symbol	Min	Non	Max
A1	6.28	6.33	6.38
A2	6.33	6.38	6.43
A3	7.52	7.62	7.72
A4	7.80	8.40	9.00
B1	9.15	9.20	9.25
B2	9.20	9.25	9.30
C		5.57	
D		1.52	
E	0.43	0.45	0.47
F		2.54	
G		0.25	
H	1.54	1.59	1.64
I	3.22	3.27	3.32
R		0.20	
M1	9°	10°	11°
M2	11°	12°	13°



Important statement:

- TUDI Semiconductor reserves the right to modify the product manual without prior notice! Before placing an order, customers need to confirm whether the obtained information is the latest version and verify the completeness of the relevant information.
- Any semi-guide product is subject to failure or malfunction under specified conditions. It is the buyer's responsibility to comply with safety standards when using TUDI Semiconductor products for system design and whole machine manufacturing. And take the appropriate safety measures to avoid the potential in the risk of loss of personal injury or loss of property situation!
- TUDI Semiconductor products have not been licensed for life support, military, and aerospace applications, and therefore TUDI Semiconductor is not responsible for any consequences arising from the use of this product in these areas.
- If any or all TUDI Semiconductor products (including technical data, services) described or contained in this document are subject to any applicable local export control laws and regulations, they may not be exported without an export license from the relevant authorities in accordance with such laws.
- The specifications of any and all TUDI Semiconductor products described or contained in this document specify the performance, characteristics, and functionality of said products in their standalone state, but do not guarantee the performance, characteristics, and functionality of said products installed in Customer's products or equipment. In order to verify symptoms and conditions that cannot be evaluated in a standalone device, the Customer should ultimately evaluate and test the device installed in the Customer's product device.
- TUDI Semiconductor documentation is only allowed to be copied without any alteration of the content and with the relevant authorization. TUDI Semiconductor assumes no responsibility or liability for altered documents.
- TUDI Semiconductor is committed to becoming the preferred semiconductor brand for customers, and TUDI Semiconductor will strive to provide customers with better performance and better quality products.