



**规格书目录**  
**Specification Content**

<b>No.</b>	<b>规格书内容/Specification</b>	<b>页码/Page</b>
<b>0</b>	<b>目录/Contents</b>	<b>2</b>
<b>0</b>	<b>修订履历/Change Records</b>	<b>3</b>
<b>1</b>	<b>适用范围/Applicable scope</b>	<b>4</b>
<b>2</b>	<b>使用条件/Applicable Conditions</b>	<b>4</b>
<b>3</b>	<b>测定条件/Masurement Conditions</b>	<b>4</b>
<b>4</b>	<b>性能标准/ characteristics Standard</b>	<b>5</b>
<b>5</b>	<b>机械性能/Mechanical characteristics</b>	<b>6</b>
<b>6</b>	<b>测试方法/Test Method</b>	<b>6</b>
<b>7</b>	<b>可靠性性能/Reliability characteristics</b>	<b>7-11</b>
<b>8</b>	<b>使用注意事项/Attention</b>	<b>12</b>
<b>9</b>	<b>包装/Packaging</b>	<b>13-14</b>
<b>10</b>	<b>产品 2D 图/ Product 2D drawing</b>	<b>15</b>



# 马达需求规格书/Linear Vibrator Specification

## 1. 适用范围/Applicable scope

本规格书适用于线性振动马达 080935 系列，包括使用条件、测定条件，性能标准，机械性能，测试方法，可靠性试验，使用注意事项，包装和外形图等。

This specification applies to linear type motor 080935 series, the document contains applicable conditions, measurement conditions, performance standard, mechanical characteristic, test methods, reliability tests, usage attentions, packing and outline drawings.

## 2. 使用条件/Applicable conditions

编号/Number	名称/Item	规格/Specification	备注/Notes
2.1	额定电压 Rated Voltage	0.9Vrms AC	最大工作电压 Input voltage should be lower than 0.9Vrms
2.2	工作电压 Work Voltage	0.1-0.95Vrms AC	低于额定电压时马达能振动;高于额定电压时马达能正常工作 The linear vibrator can vibrate below the rated voltage; while can vibrate over the rated voltage with no problem
2.3	振动方向 Vibration Direction	X axis	振子振动方向为产品的长度方向 The vibration direction is defined as the product length direction
2.4	使用环境 Operating Environment	-20℃~+70℃, Ordinary Humidity:0-95%RH	无水汽凝结 No condensation of moisture
2.5	输入频率 Input Frequency	170 Hz	谐振频率 Resonant Frequency
2.6	保存条件/Storage Conditions	-40℃~+85℃, Ordinary Humidity:65±20%RH	无水汽凝结 No condensation of moisture

## 3. 测定条件/Measurement Conditions

一般情况下，马达可以在 22~28℃，相对湿度 45~85%RH 的环境中测试.为保证一致性，测试应在下表规定内进行。

Normally, the vibrator could be measured under 22~28℃,45~85%RH. For coherence, it must be measured under below environment requirements.

项目/Item	规格/Specification
3-1	温度/Temperature 25℃±3℃
3-2	湿度/Humidity 65±20%RH
3-3	气压/Air Pressure 1011±40 hpa

#### 4、性能标准/ Characteristics Standard

项目/Item		规格/Specification	测试条件/Test Condition
4-1	额定电压 Rated Voltage	0.9Vrms AC, Sine wave	0.9Vrms AC, Sine wave
4-2	额定频率 Rated Frequency	170Hz	@nominal rated voltage
4-3	额定电流 Rated Current	Max 145mArms	0.9Vrms AC, F0, sine wave Refer to Figure 1
4-4	F0 点振动量 Acceleration	0.65 ± 0.15Grms	0.9Vrms AC, F0, sine wave
4-5	频率特性 Frequency Characteristics	170 ± 10Hz	
4-6	瞬态振动量 Transient vibration acceleration	0.90+0.15/-0.2Gp	9Vp+1cycle sine wave@F0
4-7	上升时间 Rise Time	Max 100ms 额定电压及谐振频率下，从上电开始，振动量上升至 90%额定振动量的时间 The time from 0 up to 90% maximum acceleration.	170Hz, 0.9Vrms AC, sine wave
4-8	下降时间 Falling Time	Max 130ms 驱动电压撤销后，从下电开始，振动量下降至 10%额定振动量的时间 The decay time free fall acceleration from 100% down to 10%.	170Hz, 0.9Vrms AC, sine wave
4-9	绝缘电阻 Insulation Resistance	10MΩ Min (100V)	在 100V 直流电压下马达端子与外壳的绝缘电阻 Min 10MΩ @100V DC between terminal and housing
4-10	端子阻抗 Resistance	8.0±1.0 Ohm	25°C ± 3°C

## 5、机械性能/Mechanical characteristics

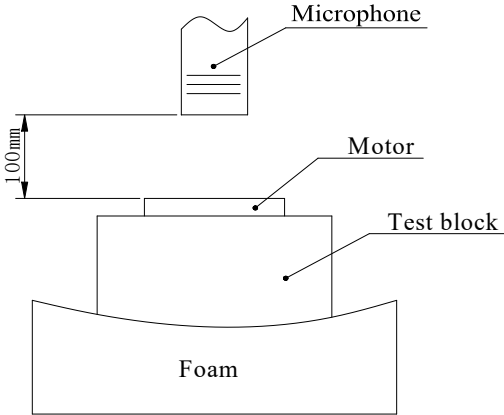
项目/Item		规格/Specification	测试条件/Test Conditions
5-1	噪音/Noise	45 dBA Max. 距离麦克风10 cm 的位置 10cm distance from microphone	170Hz, 0.9Vrms AC, sine wave/9Vp+1 cycle sine wave 背景噪音:不大于28dBA. Background noise 28dBA Max. 
5-2	马达尺寸 /Vibrator Size	L9.0*W8.0*H3.5 mm	micrometer calipers

## 6、测试方法/Test Method

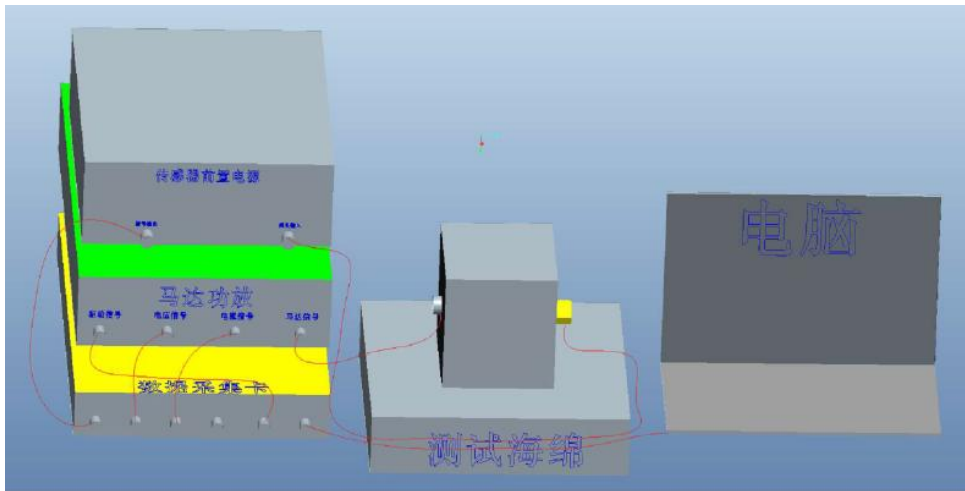

Linear Vibrator Test Method/线性马达测试方法

### Note:

- 测试工装尺寸及重量: 40mm\*40mm\*40mm, 100g。  
The dimension and weight of test jig: 40mm\*40mm\*40mm, weight:100g.
- 马达必须放置必须穿过测试工装的质心。  
The motor should be fixed by cross the center of test jig.
- 加速度探头必须放置在马达的正对面。  
The acceleration sensor should be fixed on the opposite of motor.

## 7、可靠性性能/Reliability characteristics

### 7.1 机械试验

项目/Item		测试条件/Test Condition	合格判据/Judgment	数量/Number
7.1.1	静态压力试验 /static-pressure test	50N, 1min	试验后马达外观无明显变形, 开裂等, 高度满足 $3.5 \pm 0.05$ , 性能满足 7.5 condition A 判定要求 After the test, the 7.5 condition A pass criteria must be satisfied and obvious deformation is not allowed, the height meet $3.5 \pm 0.05$ mm.	20
7.1.2	滚筒试验 /Tumbling test	220g $\pm$ 5g 跌落工装, 常规: 高度 0.5 米, 次数为 500 次, 跌落的接触面为钢板; 推荐 10-12 次/分钟 220g $\pm$ 5g test jig (the motor contained), half a meter high, 500 times, the contact surface is steel base, 10-12 per minute recommended.	试验后马达外观无明显变形, 开裂等, 高度满足 $3.5 \pm 0.05$ , 性能满足 7.5 condition A 判定要求 After the test, the 7.5 condition A pass criteria must be satisfied and obvious deformation is not allowed, the height meet $3.5 \pm 0.05$ mm.	20
7.1.3	跌落试验 /Free fall	1. 重量约 220g (包括马达本身) 落向花岗岩地面 2. 高度: 1.5m 3. 方向: 6 个面, 4 个角 4. 次数: 3 Cycles 220g $\pm$ 5g test jig (the motor contained), drop from 1.5m, the contact surface is monto granite base, six faces and four corners with three cycles.	试验后马达外观无明显变形, 开裂等, 高度满足 $3.5 \pm 0.05$ , 性能满足 7.5 condition A 判定要求 After the test, the 7.5 condition A pass criteria must be satisfied and obvious deformation is not allowed, the height meet $3.5 \pm 0.05$ mm.	20
7.1.4	振动试验 /Vibration test	220g $\pm$ 5g 工装常规测试: 5-500Hz, PSD=0.04g <sup>2</sup> /Hz, X/Y/Z 三轴每轴 1 小时; The motor fixed fixture weight 220g $\pm$ 5g, Frequency:5~500Hz, PSD =0.04g <sup>2</sup> /Hz Do the test for one hour per three straight shaft directions.	试验后马达外观无明显变形, 开裂等, 高度满足 $3.5 \pm 0.05$ , 性能满足 7.5 condition A 判定要求 After the test, the 7.5 condition A pass criteria must be satisfied and obvious deformation is not allowed, the height meet $3.5 \pm 0.05$ mm.	20

7.1.5	微跌试验 /Micro-drop test	220g±5g 工装, 跌落高度 0.1m, 500 次微跌/面, 按顺序 6 个面共测试 3000 次, 为 1 个循环, 共测试 6 个循环。 220g ± 5g test jig(the motor contained), drop from 0.1m, six faces with 500 times each for one cycle, six cycles.	试验后马达外观无明显变形, 开裂等, 高度满足 3.5±0.05, 性能满足 7.5 condition A 判定要求 After the test, the 7.5 condition A pass criteria must be satisfied and obvious deformation is not allowed, the height meet 3.5±0.05mm.	20
-------	--------------------------	--	--	----

## 7.2.环境试验

项目/Item	测试条件/Test Condition	合格判据/Judgment	数量/Number
7.2.1	高温存储试验 /High temperature storage test 在常温状态下, 以 1℃/min 将温度升到 85℃, 温度稳定后存储 96 小时, 然后以 1℃/min 的速率降温到常温; 保持 2 小时后取出; The temperature rise 1℃ per minute to 85℃ from normal temperature, and stay for 96 hours, then drop 1℃ per minute to normal temperature, pick out after two hours. 温度/Temperature:85±2℃ 时间/Time:96hs	试验后马达性能满足 7.5 condition A 判定要求 After the test, the 7.5 condition A pass criteria must be satisfied.	20
7.2.2	低温存储试验 /Low temperature storage test 在常温状态下, 以 1℃/min 将温度降到 -40℃, 温度稳定后存储 96 小时, 然后以 1℃/min 的速率升温到常温, 保持 2 小时后取出; The temperature drop 1℃ per minute to -40℃ from normal temperature, and stay for 96 hours, then rise 1℃ per minute to normal temperature, pick out after two hours. 温度/Temperature:-40±2℃ 时间/Time:96 hours	试验后马达性能满足 7.5 condition A 判定要求 After the test, the 7.5 condition A pass criteria must be satisfied.	20
7.2.3	温度冲击试验 /Temperature shock 低温: -40℃ 30 分钟, 高温: 85℃ 30 分钟, 温度转换时间小于 20 秒, 共 50 个循环。 -40℃@ 30 minutes and 85℃@ 30 minutes, the exchange time within 20 seconds, 50 cycles.	试验后马达性能满足 7.5 condition A 判定要求 After the test, the 7.5 condition A pass criteria must be satisfied.	20
7.2.4	高温高湿存储试验 /Temperature and humidity test 在常温状态下, 温度以 1℃/min 的速率上升至 85℃, 湿度保持在 85%RH, 放置 500 小时, 然后以 1℃/min 的速率降温到常温; 保持 2 小时后取出; The temperature rise 1℃ per minute to 85℃, with 85%RH, for 500 hours.	试验后马达性能满足 7.5 condition A 判定要求 After the test, the 7.5 condition A pass criteria must be satisfied.	20

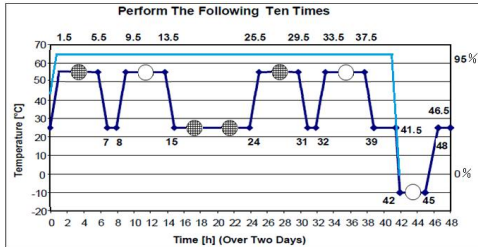
7.2.5	盐雾试验/Salt spray test	<p>设置喷雾环境温度 35℃，盐雾浓度为 5% 的 NaCl 溶液，在 35℃ 条件连续喷雾 24 小时(盐雾量要求:用面积为 80 平方厘米的器皿连续收集雾化沉积溶液，达到 1mL-2mL/h)；</p> <p>The five percentage NaCl solutions (by mass) is sprayed continuously for 24 hours at 35℃, then remove the products from the test condition, one cycle;</p>	<p>试验过程中，任一时间点停止试验，马达外壳及 FPC pad 腐蚀情况满足规格书要求</p> <p>Stop the test at any time, the crust and FPC pad corrosion situation must meet the specification request.</p>	20
7.2.6	交变湿热试验 /Temperature Humidity storage test	<p>按温湿曲线循环两次</p>  <p>The deep blue is temperature curve, and the light blue is humidity curve. Two cycles following the above temperature-humidity curve.</p>	<p>试验后马达性能满足 7.5 condition A 判定要求</p> <p>After the test, the 7.5 condition A pass criteria must be satisfied.</p>	20

### 7.3 寿命试验

项目/Item	测试条件/Test Condition	判定标准/Judgment	数量 /Number	
7.3.1	<p>常温寿命试验 Lifetime</p>	<p>驱动电压设为额定电压、过载电压为允许最大电压，驱动频率为马达谐振频率，带有过载启动与刹车，2sON/1sOFF，100 万次循环；</p> <p>F0 pure sine wave drive at rated voltage, 2.0s on/ 1.0s off, one million cycles at room temperature.</p>	<p>试验后马达性能满足 7.5 condition A 判定要求</p> <p>After the test, the 7.5 condition A pass criteria must be satisfied.</p>	20
7.3.2	<p>长期温度循环 上电 /Long-term lifetime with temperature</p>	<p>温度变化范围 -20 °C~55°C，各停留 30min，温变 10 °C /min，共进行 78 个循环。</p> <p>2sON/1sOFF</p> <p>-20 °C~55°C， stay 30 minutes per 10°C /min, total 78 cycles. 2sON/1sOFF</p>	<p>试验后马达性能满足 7.5 condition A 判定要求</p> <p>After the test, the 7.5 condition A pass criteria must be satisfied.</p>	20

7.3.3	高温高湿寿命试验 /High temperature and humidity life	在常温状态下，温度以1℃/min的速率上升至65℃，湿度保持在95%RH，长振运行24小时，然后以1℃/min的速率降温到常温，保持2小时后取出。 65℃, 95%RH, F0 pure sine wave drive at rated voltage for 24hours.	试验后马达性能满足7.5 condition A判定要求 After the test, the 7.5 condition A pass criteria must be satisfied.	20
7.3.4	连续寿命试验 /Continuous life	-10℃工作24小时,55℃工作24小时,25℃常温192小时，合计240小时 24 hours@-10℃, 24 hours@55℃, and 192 hours@25℃, total 240 hours,@rated voltage,@F0.	试验后马达性能满足7.5 condition A判定要求 After the test, the 7.5 condition A pass criteria must be satisfied.	20

#### 7.4. 夹具及试验要求 Jig and test methods

##### 7.4.1. 跌落工装及方向 Drop jig and drop direction

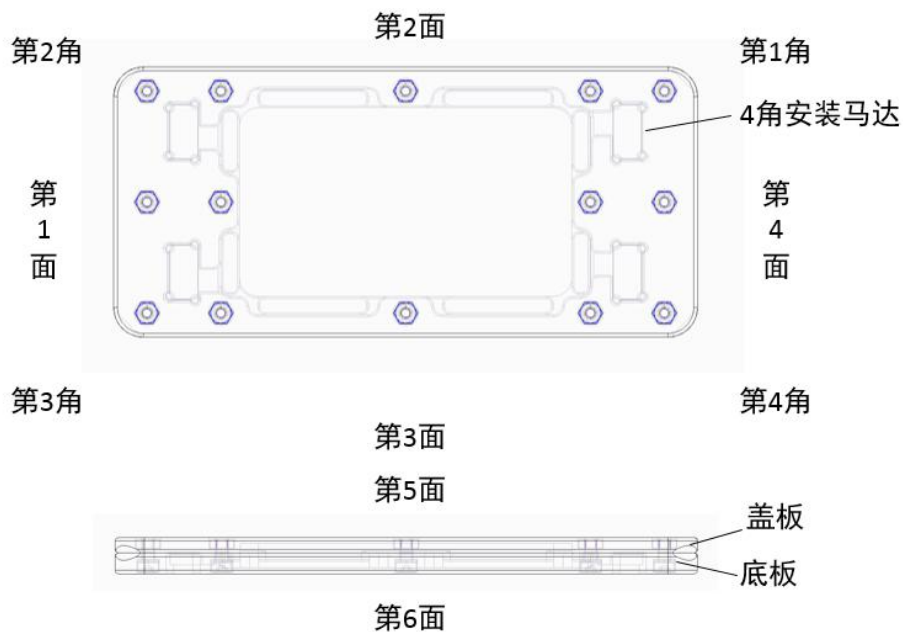

马达在夹具中的位置参考上图

##### 7.4.2. 工装压力标准: Jig pressure standard

马达在测试工装中的表面受压管控标准为  $10/\pm 5\text{N}$ ，详细工装图纸由客户确定。

The surface compression of the motor is  $10\pm 5\text{N}$  in the test jig, and the detail drawings are determined by customers.

## 7.5、判断特性/Requirements after reliable test

试验后应满足下列条件/Test pass criteria

After reliability tests, all test samples must be meet the following conditions, otherwise they will be regarded as NG.

Condition A:

F0 变化量: 不超出初始值 $\pm 10\text{Hz}$ ;

Within  $\pm 10\text{Hz}$  of F0 measured before tests.

工作电流变化:  $\leq \pm 20\%$

Within 20% of work current measured before tests

振动量变化:  $\leq \pm 20\%$

Within 20% of Acceleration measured before tests @ F0

停止时间变化不超过 $\pm 20\text{ms}$ ;

Within 20ms of stop time measured before tests @ F0

噪音:  $\leq 48\text{dB}$ ;

Max 48dB(A);

## 8、使用注意事项/ Points for Attentions

8-1.必须安装规格书标准使用，否则性能与寿命都将受到相当的减少，必须注意电压的使用范畴。

Make sure to use the motor in accordance with the specifications, if not, the lifetime might be reduced accordingly, pay high attention to the range of the voltage.

8-2.建议马达在 6 个月内使用,不要在以下环境中使用及保存.

8-2-1.高温与高湿的场所;

8-2-2.腐蚀性气体，如：H<sub>2</sub>S,SO<sub>2</sub>,NO<sub>2</sub>,CL<sub>2</sub>;

8-2-3.生锈场所。

The motor is suggested using within 6 months. Do not use or store the motor under below environments:

8-2-1.High temperature and high humidity area;

8-2-2.Corrosive gas such as H<sub>2</sub>S,SO<sub>2</sub>,NO<sub>2</sub>,CL<sub>2</sub>;

8-2-3.Dusty area;

8-3.注意处理马达的工作环境，避免含铁质物体被马达吸住，否则马达将会产生噪音，性能会降低，从而降低产品的可靠性。

Pay attention to the working environment of the motor, avoid any iron material sucked by the motor, or the motor might cause noise and the performance will be degraded, meanwhile, the reliability might be reduced.

8-4.应确信本产品不会违背相关的标准，以及法律法规与行政令。

Make sure the product will not violate any local relevant standards, as well as laws and regulations.

8-5.拿马达时，要轻拿轻放。

Handle with care.

8-6.钢板面边缘有少许锈斑是允许的。

A little rusty spot at the steel plate surface is allowed.

8-7.我司遵循持续发展的策略，在不预先通知的情况下，有对产品（部品）进行修改和改进的权利，当然这些都不会影响马达的特性及使用功能。

Our company follow the sustainable developing strategy, and have the right to make change and improvements to our product without giving notice in advance . of course ,these changes and improvements will not affect the characteristics and function of the motor.

## 9. 包装/Packing

2022-04-06	说明书/Specification	编号/No KOTL-L-B-049	12 / 15
------------	-------------------	--------------------	---------

## 9.1 载带包装 (材料:PS 黑色 防静电) Carrier tape (Material: PS, black, anti-static)

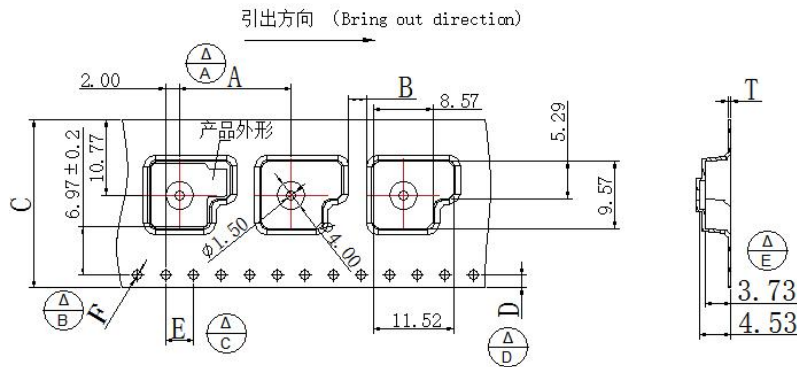

尺寸栏 (dimensions)	
D	1.75±0.10
F	1.50 ± 0.10 / 0.00
E	4.00±0.10
10°E	40.00±0.20
C	24.00±0.20
拔模角 (draft angle)	5° -6°
T	0.40 ± 0.05
B	2.6
A	16.00±0.10

### 技术要求:

1. 10个边孔的累计公差不能超过±0.1mm。

The accumulative tolerance of ten side holes should not exceed 0.1mm

2. 材料规格: PS 黑色防静电, 厚度0.4mm。

Material specification: PS, Black, anti-static, 0.4mm thick.

3. 13英寸卷轮卷装长度: 15.36米 (参考)。

The length of the 13 inch reel is 15.36 meters. (for references)

4. 13吋卷轮包装零件总颗数: 960颗, 实际包装数量900颗。产品包装时内圈空格30颗, 产品包装时外圈空格30颗。

The total packing numbers the reel: 960 pieces, with inner 30 pieces, and outer 30 empty pieces, the actual packing motor number is 900 pieces.

5. 胶盘颜色: 蓝色。

The reel color is blue.

6. 产品符合金龙机电股份有限公司最新版《禁用有害物质标准》。

The tape satisfied the latest Kotl <<prohibited hazardous substances standard>> .

7. 标记Δ为重要控制项目, 未注公差按0.1mm。

The dimension labeled Δ are important, and the tolerance not indicated is 0.1mm.

8. 所有尺寸设计参照EIA-481-C-2003。

All the dimensions design should follow the EIA-481-C-2003.

9. 载带在250mm长度以内最大弯曲度不超过1mm (见下图)。

The maximum bending of the tape should not exceed 1mm within 250mm. (see the picture below)

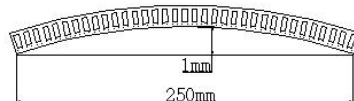

## 9.2 纸箱包装 Carton packing

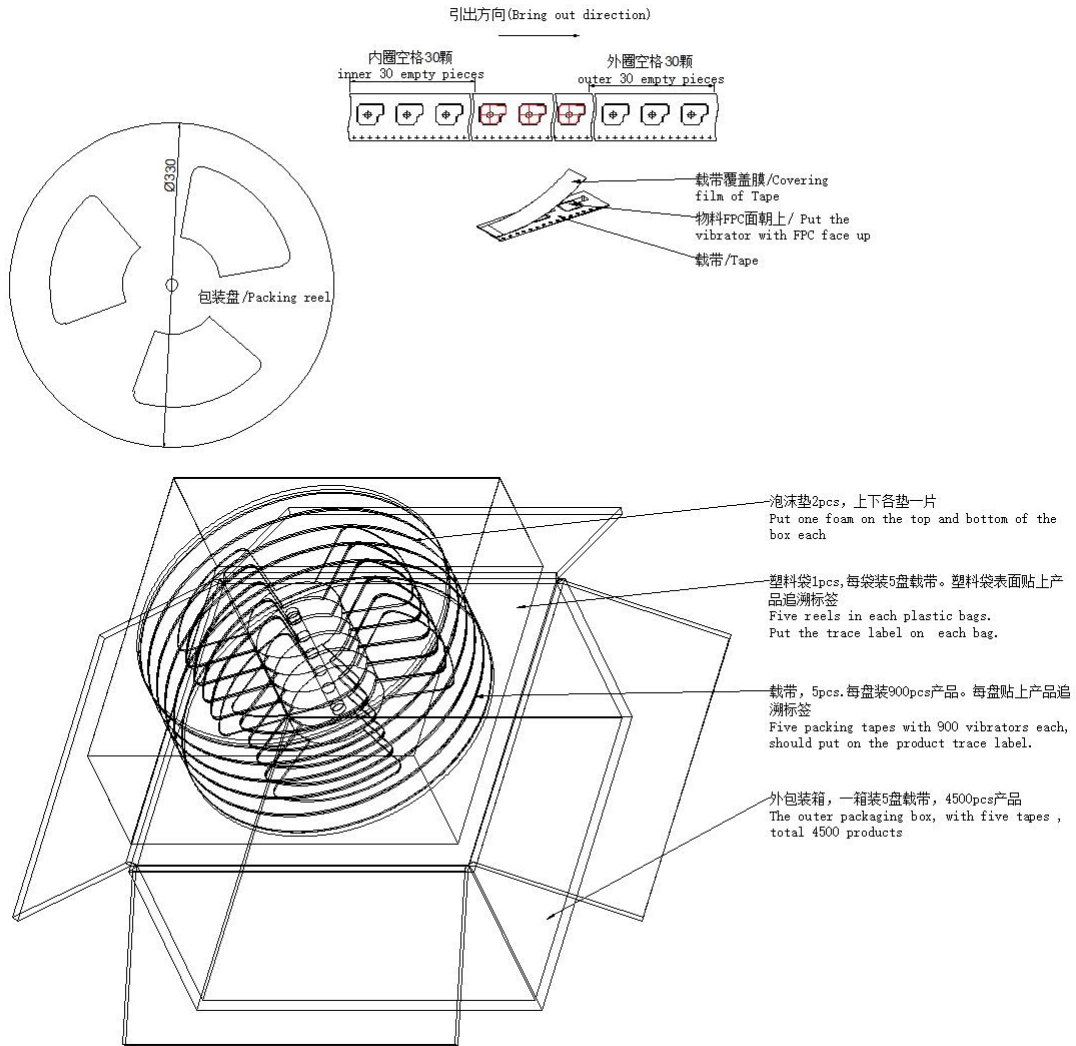

## 10、产品 2D 图/ Product 2D drawing

03.09.L080935.I001F

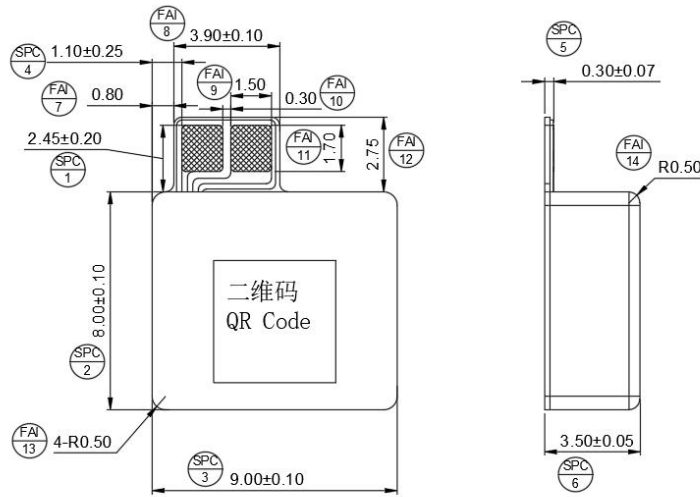

普(通)用 件 登 记
旧底图总号
底图总号
签 字
日 期
档案员 日期

技术要求:  
 1)未注公差±0.1。  
 2)标记SPC项目为关键控制项目,需满足CPK≥1.33要求,标记Δ为重要控制项目。

标记	处数	版本号	签字	日期
设计			标准化	
制图			审定	
校对			批准	
工艺			日期	

成品外形图

金龙机电股份有限公司	
03.09.L080935.I001F	

技术要求/Technical Request:

1)未注公差±0.1。

The tolerance not indicated is 0.1mm.

2)标记SPC项目为关键控制项目,需满足CPK≥1.33要求,标记Δ为重要控制项目,标记FAI为管控项目。

The dimensions labeled SPC are key control items, should meet the CPK≥1.33, and the dimensions labeled Δ are important items, and the ones labeled FAI are control items.