

Features

- Ultra low leakage: nA level
- Operating voltage: 24V
- Low clamping voltage
- Complies with following standards:
 - IEC 61000-4-2 (ESD) immunity test
 - Air discharge: $\pm 30\text{kV}$
 - Contact discharge: $\pm 30\text{kV}$
 - IEC61000-4-4 (EFT) 40A (5/50ns)
 - IEC61000-4-5 (Lightning) 4A (8/20 μs)
- RoHS Compliant

Dimensions SOT-23



Applications

- Cell Phone Handsets and Accessories
- Microprocessor based equipment
- Personal Digital Assistants (PDA 's)
- Notebooks, Desktops, and Servers
- Portable Instrumentation
- Networking and Telecom
- Serial and Parallel Ports
- Peripherals

Pin Configuration

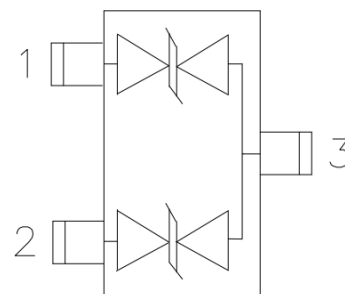

Mechanical Characteristics

- Package: SOT-23
- Lead Finish: Lead Free
- UL Flammability Classification Rating 94V-0
- Quantity Per Reel: 3,000 pcs
- Reel Size: 7 inch
- Device Marking: tAN

Absolute Maximum Ratings (T_{amb}=25°C unless otherwise specified)

Parameter	Symbol	Value	Unit
Peak Pulse Power (8/20 μs)	P _{pp}	160	W
ESD per IEC 61000-4-2 (Air)	V _{ESD}	± 30	kV
ESD per IEC 61000-4-2 (Contact)		± 30	
Operating Temperature Range	T _J	-40 to +125	°C
Storage Temperature Range	T _{STJ}	-55 to +150	°C

Electrical Characteristics (TA=25°C unless otherwise specified)

Parameter	Symbol	Test Condition	Min	Typ	Max	Unit
Reverse Working Voltage	V_{RWM}				24	V
Breakdown Voltage	V_{BR}	$I_T = 1\text{mA}$	26	28	31	V
Reverse Leakage Current	I_R	$V_{RWM} = 24\text{V}$			0.1	μA
Clamping Voltage	V_C	$I_{PP} = 1\text{A}$ (8 x 20 μs pulse)		30	32	V
Clamping Voltage	V_C	$I_{PP} = 4\text{A}$ (8 x 20 μs pulse)		35	40	V
Junction Capacitance	C_J	$V_R = 0\text{V}$, $f = 1\text{MHz}$		10	20	pF

Electrical Parameters (TA=25°C unless otherwise specified)

Symbol	Parameter
V_{RWM}	Peak Reverse Working Voltage
I_R	Reverse Leakage Current @ V_{RWM}
V_{BR}	Breakdown Voltage @ I_T
I_T	Test Current
I_{PP}	Maximum Reverse Peak Pulse Current
V_C	Clamping Voltage @ I_{PP}

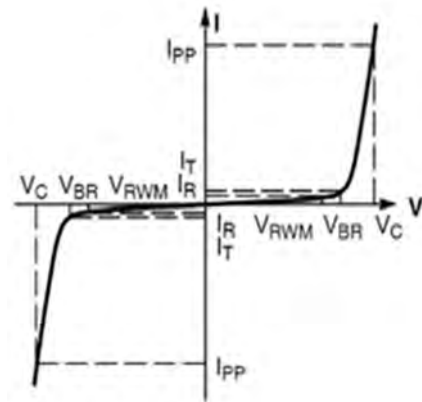

Typical Performance Characteristics(TA=25°C unless otherwise specified)

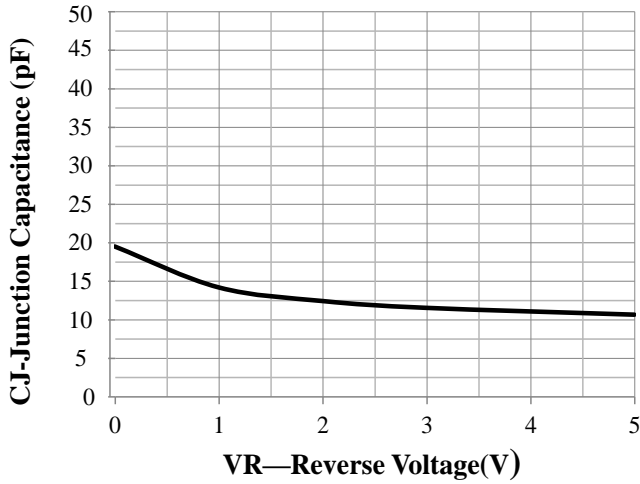

Junction Capacitance vs. Reverse Voltage

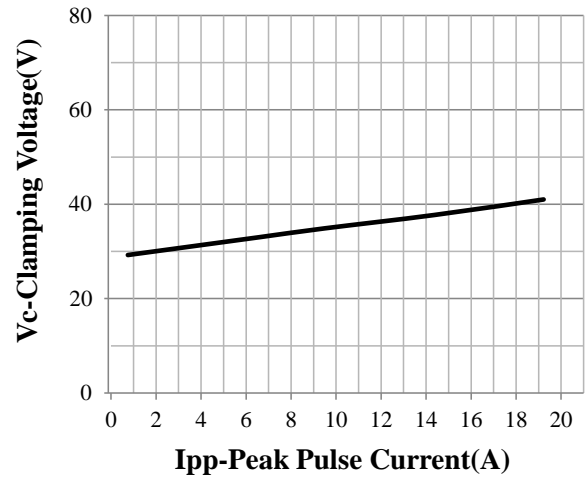

Clamping Voltage vs. Peak Pulse Current

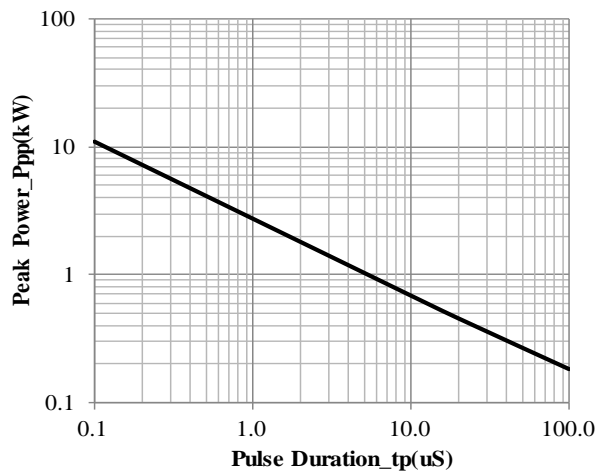

Peak Pulse Power vs. Pulse Time

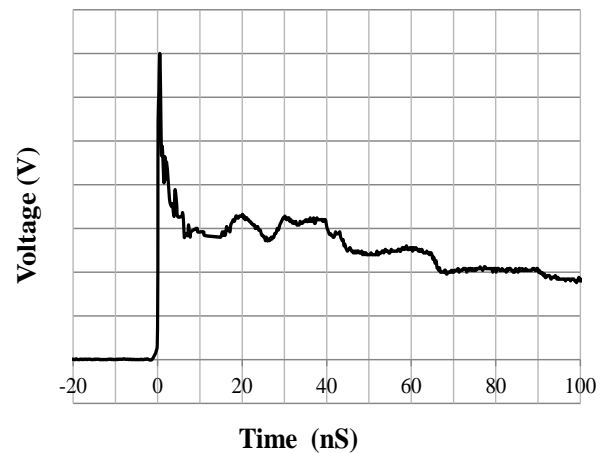

IEC61000-4-2 Pulse Waveform

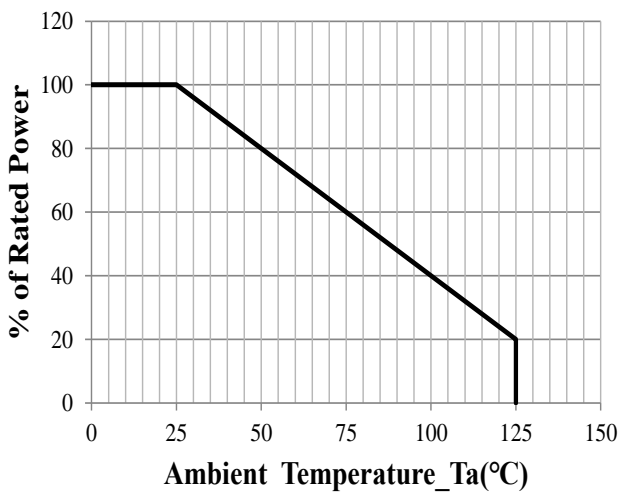

Power Derating Curve

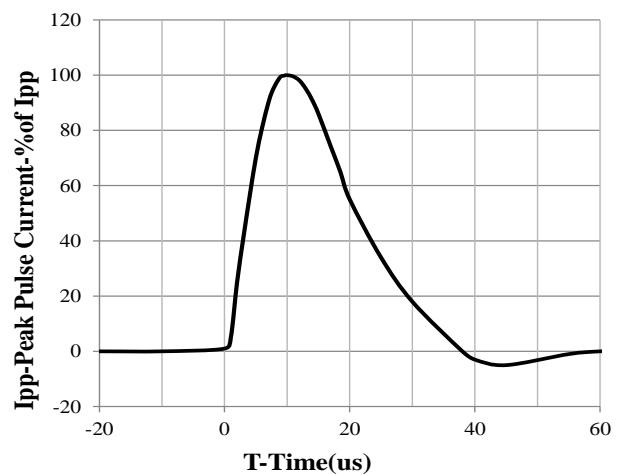

8 X 20us Pulse Waveform

SOT-23 Package Outline Drawing

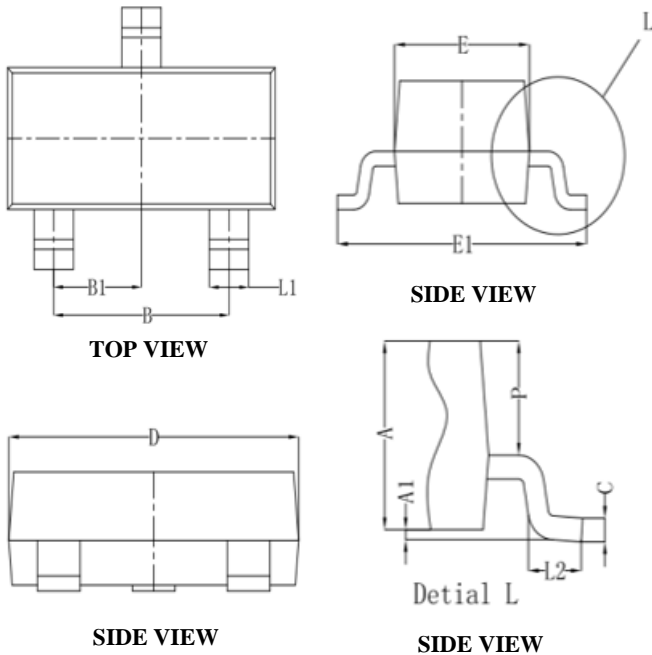

SYM	DIMENSIONS					
	MILLIMETERS			INCHES		
	Min	Typ	Max	Min	Typ	Max
A	0.900	1.000	1.100	0.0354	0.0394	0.0433
A1	0.000	0.050	0.100	0.0000	0.0020	0.0039
B	1.900 TYP			0.0748 TYP		
B1	0.950 TYP			0.0374 TYP		
C	0.100	0.110	0.120	0.0039	0.0043	0.0047
D	2.800	2.900	3.000	0.1102	0.1142	0.1181
E	1.250	1.300	1.350	0.0492	0.0512	0.0531
E1	2.250	2.400	2.550	0.0886	0.0945	0.1004
L1	0.350	0.400	0.500	0.0138	0.0157	0.0197
L2	0.200	0.350	0.450	0.0079	0.0138	0.0177
P	0.550	0.575	0.600	0.0217	0.0226	0.0236

Suggested Land Pattern

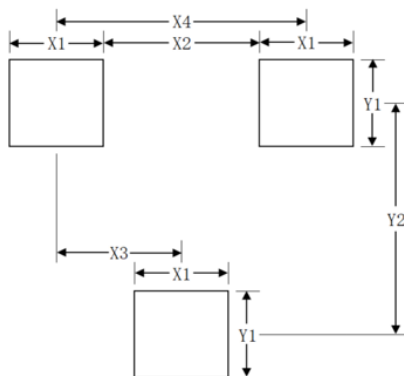

SYM	DIMENSIONS	
	MILLIMETER	INCHES
X1	0.800	0.031
X2	1.100	0.043
X3	0.950	0.037
X4	1.900	0.075
Y1	0.800	0.031
Y2	2.200	0.087

NOTICE

Leiditech reserves the right to make modifications, enhancements, improvements, corrections or other changes without further notice to any product herein. Leiditech does not assume any liability arising out of the application or use of any product described herein.