

## FEATURES

- Continuous short-circuit protection
- No-load input current as low as 8mA
- Operating ambient temperature range: -40°C to +105°C
- High efficiency up to 85%
- I/O isolation test voltage: 3k VDC
- Industry standard pin-out

1W isolated DC-DC converter

Fixed input voltage, unregulated dual/single output

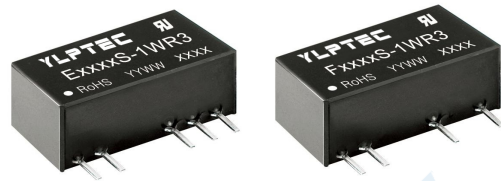

RoHS



E\_S-1WR3 & F\_S-1WR3 series are specially designed for applications where an isolated (two isolated) voltage is required in a distributed power supply system. They are suitable for: pure digital circuits, low frequency analog circuits, relay-driven circuits and data switching circuits.

## Selection Guide

Certification	Part No.	Input Voltage (VDC)	Output		Full Load Efficiency (%) Min./Typ.	Capacitive Load(μF) Max.*	
		Nominal (Range)	Voltage (VDC)	Current (mA) Max./Min.			
--	E0303S-1WR3	3.3 (2.97-3.63)	±3.3	±150/±15	74/78	1200	
	E0305S-1WR3		±5	±100/±10	78/82	1200	
	E0309S-1WR3		±9	±56/±6	81/85	470	
	E0312S-1WR3		±12	±42/±5	78/82	220	
	E0315S-1WR3		±15	±34/±4	78/82	220	
	E0324S-1WR3		±24	±21/±2	80/84	100	
	F0303S-1WR3		3.3	303/30	75/79	2400	
	F0305S-1WR3		5	200/20	78/82	2400	
	F0309S-1WR3		9	111/11	81/85	1000	
	F0312S-1WR3		12	83/8	78/82	560	
	F0315S-1WR3		15	67/7	78/82	560	
	F0324S-1WR3		24	42/4	80/84	220	
	E0503S-1WR3	5 (4.5-5.5)	±3.3	±152/±15	70/74	1200	
	E0505S-1WR3		±5	±100/±10	78/82	1200	
	E0509S-1WR3		±9	±56/±6	79/83	470	
	E0512S-1WR3		±12	±42/±5	79/83	220	
	E0515S-1WR3		±15	±34/±4	79/83	220	
	E0524S-1WR3		±24	±21/±3	81/85	100	
	F0503S-1WR3		3.3	303/30	70/74	2400	
	F0505S-1WR3		5	200/20	78/82	2400	
	F0509S-1WR3		9	111/12	79/83	1000	
	F0512S-1WR3		12	84/9	79/83	560	
	F0515S-1WR3		15	67/7	79/83	560	
	F0524S-1WR3		24	42/4	81/85	220	
	F0909S-1WR3		9 (8.1-9.9)	9	111/12	77/81	470

--	E1203S-1WR3	12 (10.8-13.2)	±3.3	±152/±15	71/75	1200	
	E1205S-1WR3		±5	±100/±10	76/80	1200	
	E1209S-1WR3		±9	±56/±5	76/80	470	
	E1212S-1WR3		±12	±42/±5	77/81	220	
	E1215S-1WR3		±15	±34/±4	77/81	220	
	E1224S-1WR3		±24	±21/±2	76/80	100	
	F1203S-1WR3		3.3	303/30	71/75	2400	
	F1205S-1WR3		5	200/20	76/80	2400	
	F1209S-1WR3		9	111/12	76/80	1000	
	F1212S-1WR3		12	83/9	76/80	560	
	F1215S-1WR3		15	67/7	77/81	560	
	F1224S-1WR3		24	42/5	77/81	220	
	E1505S-1WR3	15 (13.5-16.5)	±5	±100/±10	76/80	1200	
	E1509S-1WR3		±9	±56/±5	76/80	470	
	E1512S-1WR3		±12	±42/±5	76/80	220	
	E1515S-1WR3		±15	±34/±4	77/81	220	
	E1524S-1WR3		±24	±21/±2	77/81	100	
	F1505S-1WR3		5	200/20	76/80	2400	
	F1509S-1WR3		9	111/12	76/80	1000	
	F1512S-1WR3		12	83/9	76/80	560	
	F1515S-1WR3		15	67/7	77/81	560	
	F1524S-1WR3		24	42/5	77/81	220	
	E2403S-1WR3		24 (21.6-26.4)	±3.3	±150/±15	72/76	1200
	E2405S-1WR3			±5	±100/±10	74/80	1200
E2409S-1WR3	±9	±56/±5		74/80	470		
E2412S-1WR3	±12	±42/±5		75/81	220		
E2415S-1WR3	±15	±34/±4		73/79	220		
E2424S-1WR3	±24	±21/±2		74/80	100		
F2403S-1WR3	3.3	303/30		69/75	2400		
F2405S-1WR3	5	200/20		73/79	2400		
F2407S-1WR3	7.2	139/13		74/80	1000		
F2409S-1WR3	9	111/12		74/80	1000		
F2412S-1WR3	12	83/9		75/81	560		
F2415S-1WR3	15	67/7		75/81	560		
F2424S-1WR3	24	42/5	75/81	220			

Note: \*The specified maximum capacitive load for positive and negative output is identical.

## Input Specifications

Item	Operating Conditions		Min.	Typ.	Max.	Unit
Input Current (full load / no-load)	3.3VDC input	3.3VDC output	--	384/	405/--	mA
		other output	--	10370/	389/--	
	5VDC input	3.3VDC/5VDC output	--	18	286/--	
		9VDC/12VDC output	--	270/8	254/--	
		15VDC/24VDC output	--	241/	254/--	
	9V input		--	12241/	144/--	
	12V input	3.3VDC output	--	18	118/--	
		5VDC/9VDC output	--	137/8	110/--	
		12VDC/15VDC output	--	112/8	109/--	
				105/8		
			103/8			

Input Current (full load / no-load)	12V input	24VDC output	--	105/8	110/--	mA
	15V input	5VDC/9VDC/12VDC output	--	84/8	88/--	
		15VDC/24VDC output	--	83/8	87/--	
	24V input	3.3VDC output	--	55/8	58/--	
		5VDC/9VDC/24VDC output	--	53/8	57/--	
		12VDC output	--	53/8	56/--	
	15VDC output	--	53/8	58/--		
Reflected Ripple Current*			--	15	--	
Surge Voltage(1sec. max.)	3.3VDC input		-0.7	--	5	VDC
	5VDC input		-0.7	--	9	
	9VDC input		-0.7	--	12	
	12VDC input		-0.7	--	18	
	15VDC input		-0.7	--	21	
	24VDC input		-0.7	--	30	
Input Filter			Capacitance filter			
Hot Plug			Unavailable			

Note: \* Refer to DC-DC Converter Application Notes for detailed description of reflected ripple current test method.

## Output Specifications

Item	Operating Conditions		Min.	Typ.	Max.	Unit
Voltage Accuracy			See output regulation curves (Fig. 1)			
Linear Regulation	Input voltage change: $\pm 1\%$	3.3VDC output	--	--	1.5	--
		Other output	--	--	1.2	
Load Regulation	3.3VDC input 10% -100% load	3.3VDC output	--	12	18	%
		Other output	--	8	15	
	5VDC input 10% -100% load	3.3VDC output	--	15	20	
		5VDC output	--	10	15	
		9VDC output	--	8	10	
		12VDC output	--	7	10	
		15VDC output	--	6	10	
	9/12/15/24VDC input 10%-100% load	24VDC output	--	5	10	
		3.3VDC output	--	15	20	
		5VDC output	--	10	15	
Ripple & Noise*	20MHz bandwidth	24VDC output	--	50	100	mVp-p
		Other output	--	30	75	
Temperature Coefficient	Full load		--	$\pm 0.02$	--	$\%/^{\circ}\text{C}$
Short-Circuit Protection			Continuous, self-recovery			

Note: \* The "parallel cable" method is used for Ripple and Noise test, please refer to DC-DC Converter Application Notes for specific information.

## General Specifications

Item	Operating Conditions	Min.	Typ.	Max.	Unit
Isolation	Input-output electric strength test for 1 minute with a leakage current of 1mA max.	3000	--	--	VDC
Insulation Resistance	Input-output resistance at 500VDC	1000	--	--	M $\Omega$
Isolation Capacitance	Input-output capacitance at 100kHz/0.1V	--	20	--	pF

Operating Temperature	5VDC input	Derating when operating temperature $\geq 85^{\circ}\text{C}$ , (see Fig. 2)	-40	--	105	$^{\circ}\text{C}$
Operating Temperature	Other input	Derating when operating temperature $\geq 100^{\circ}\text{C}$ , (see Fig. 2)	-40	--	105	$^{\circ}\text{C}$
Storage Temperature			-55	--	125	
Case Temperature Rise	$T_a=25^{\circ}\text{C}$		--	25	--	
Pin Soldering Resistance Temperature	Soldering spot is 1.5mm away from case for 10 seconds		--	--	300	
Storage Humidity	Non-condensing	3.3/5VDC input	--	--	95	%RH
		Other input	5	--	95	
Vibration	9/12/15/24VDC input		10-150Hz, 5G, 0.75mm. along X, Y and Z			
Switching Frequency	Full load, nominal input voltage	3.3VDC input	--	220	--	kHz
		5VDC input	--	270	--	
		9/12/15/24VDC input	--	260	--	
MTBF	MIL-HDBK-217F@25 $^{\circ}\text{C}$		3500	--	--	k hours

### Mechanical Specifications

Case Material	Black plastic; flame-retardant and heat-resistant (UL94V-0)
Dimensions	19.65 x 6.00 x 10.16mm
Weight	2.1g(Typ.)
Cooling Method	Free air convection

### Electromagnetic Compatibility (EMC)

Emissions	CE	CISPR32/EN55032	CLASS B
	RE	CISPR32/EN55032	CLASS B
Immunity	ESD	IEC/EN61000-4-2	Air $\pm 8\text{kV}$ , Contact $\pm 6\text{kV}$ perf. Criteria B

Note: Refer to Fig. 4 for recommended circuit test.

### Typical Performance Curves

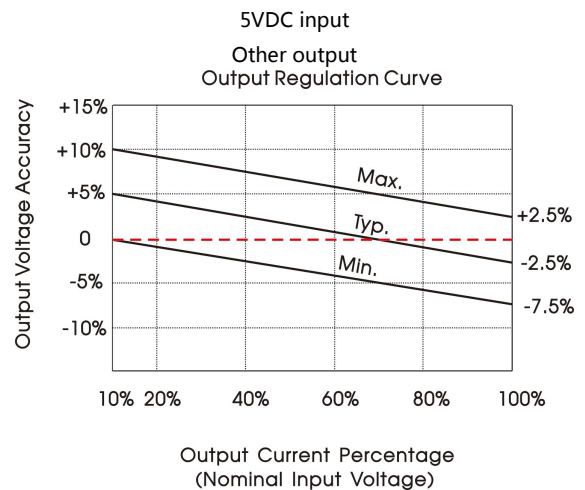
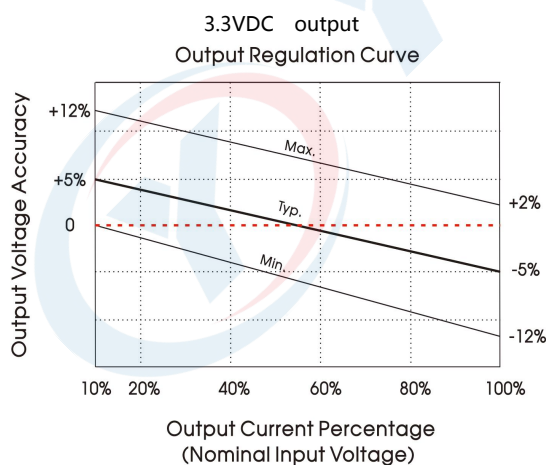

3.3/9/12/15/24VDC input  
Other output  
Output Regulation Curve

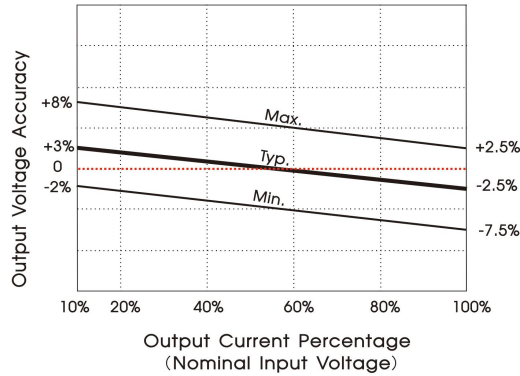
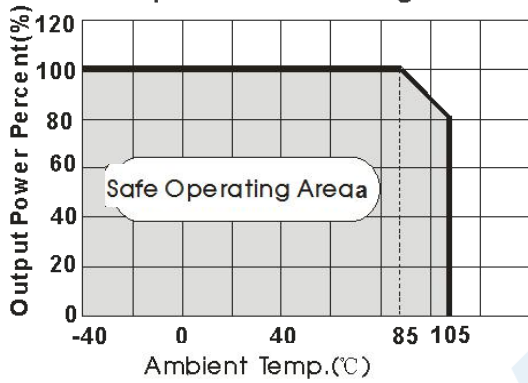

Fig. 1

5VDC input

Temperature Derating Curve



3.3/9/12/15/24VDC input

Temperature Derating Curve

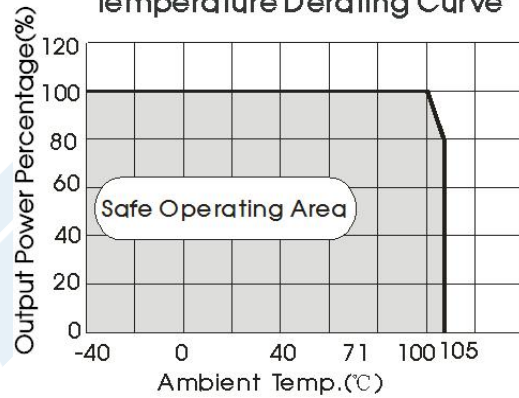
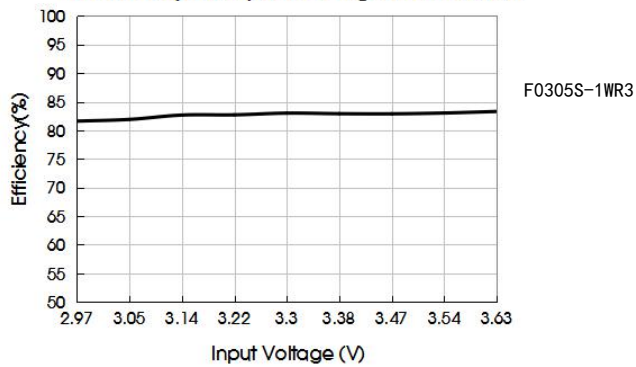
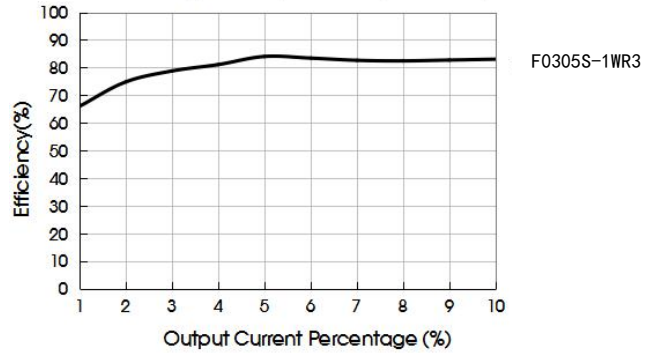

Fig. 2

Efficiency Vs Input Voltage (Full Load)



Efficiency Vs Output Load (Vin=3.3V)



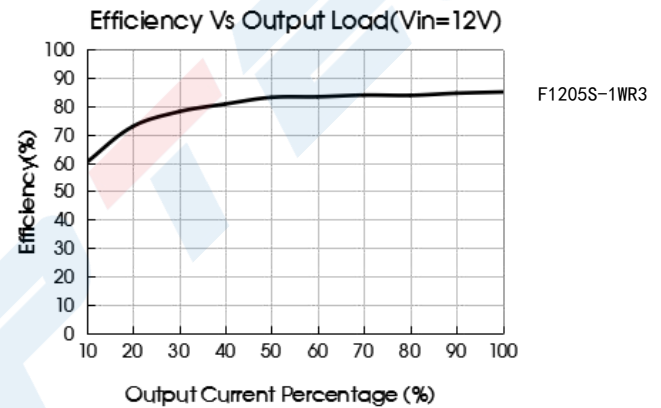
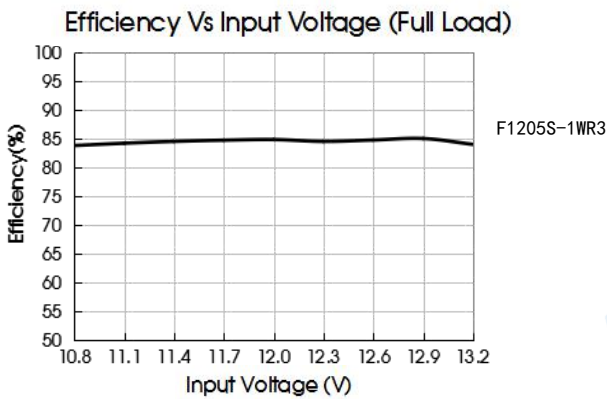
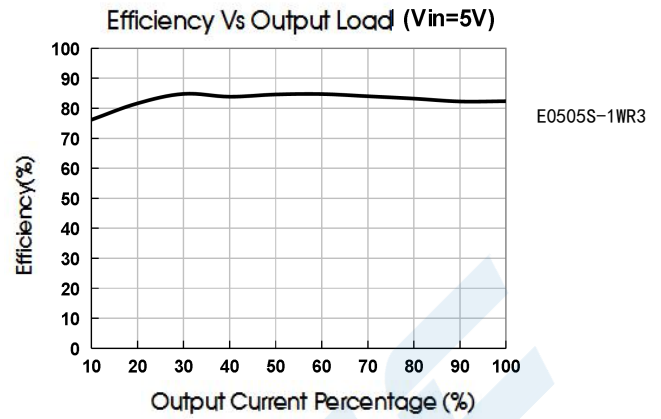
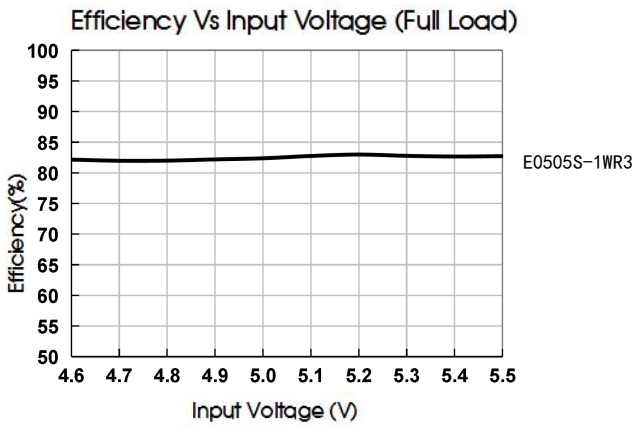

## Design Reference

### 1. Typical application

Input and/or output ripple can be further reduced, by connecting a filter capacitor from the input and/or output terminals to ground as shown in Fig. 3.

Choosing suitable filter capacitor values is very important for a smooth operation of the modules, particularly to avoid start-up problems caused by capacitor values that are too high. For recommended input and output capacitor values refer to Table 1.

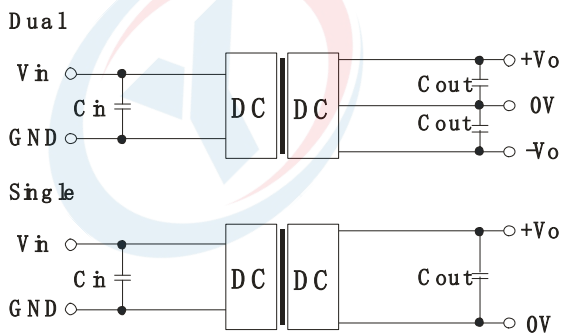

Fig. 3

Table 1: Recommended input and output capacitor values

Vin	Cin	Single output	Cout	Dual output	Cout
3.3VDC	10μF/16V	3.3VDC	10μF/16V	±3.3VDC	4.7μF/16V
5VDC	4.7μF/16V	5VDC	10μF/16V	±5VDC	4.7μF/16V
9VDC	2.2μF/25V	7.2VDC	2.2μF/16V	±9VDC	1μF/16V
12VDC	2.2μF/25V	9VDC	2.2μF/16V	±12VDC	1μF/25V
15VDC	2.2μF/25V	12VDC	2.2μF/25V	±15VDC	0.47μF/25V
24VDC	1μF/50V	15VDC	1μF/25V	±24VDC	0.47μF/50V
--	--	24VDC	1μF/50V	--	--

2. EMC compliance circuit

Dual

Single



Fig. 4

Table 2: EMC recommended circuit value table

Input voltage		3.3VDC		5VDC		Other input
Output voltage		3.3/5VDC	9/12/15/24VDC	3.3/5/9VDC	12/15/24VDC	--
EMI	C1/C2	4.7uF/16V	4.7uF/16V	4.7uF/25V	4.7uF/25V	4.7uF/50V
	CY	--	270pF /4kVDC VISHAY HGZ102MBP TDK CD45-E2GA102M-GKA	100pF/4kV	1000pF/4kV	270pF /3kVDC
	C3/C4	Refer to the Cout in table 1				
	LDM	6.8μH				

Dimensions and Recommended Layout

THIRD ANGLE PROJECTION

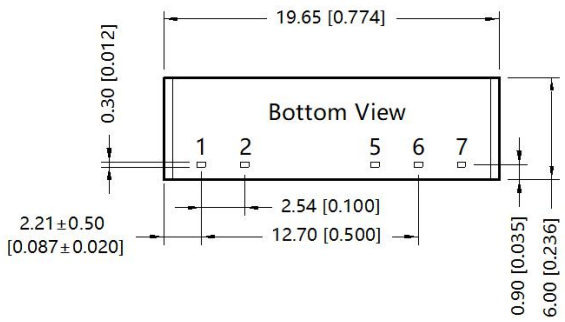
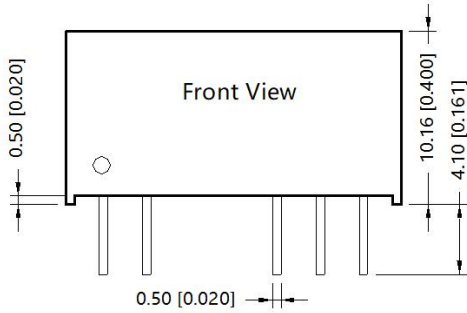

Note:  
Unit: mm[inch]  
Pin section tolerances:  $\pm 0.10[\pm 0.004]$   
General tolerances:  $\pm 0.25[\pm 0.010]$

Duals Output

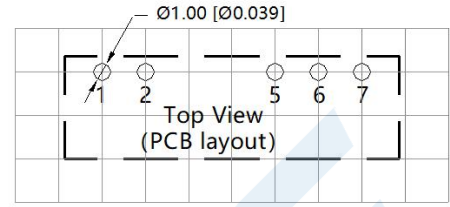

Singles Output

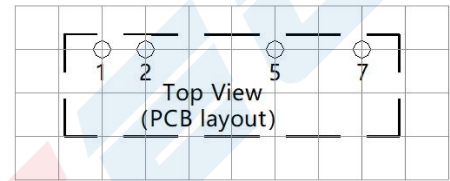

Note: Grid 2.54\*2.54mm

Pin	Single	Dual
1	Vin	Vin
2	GND	GND
5	0V	-Vo
6	No Pin	0V
7	+Vo	+Vo