

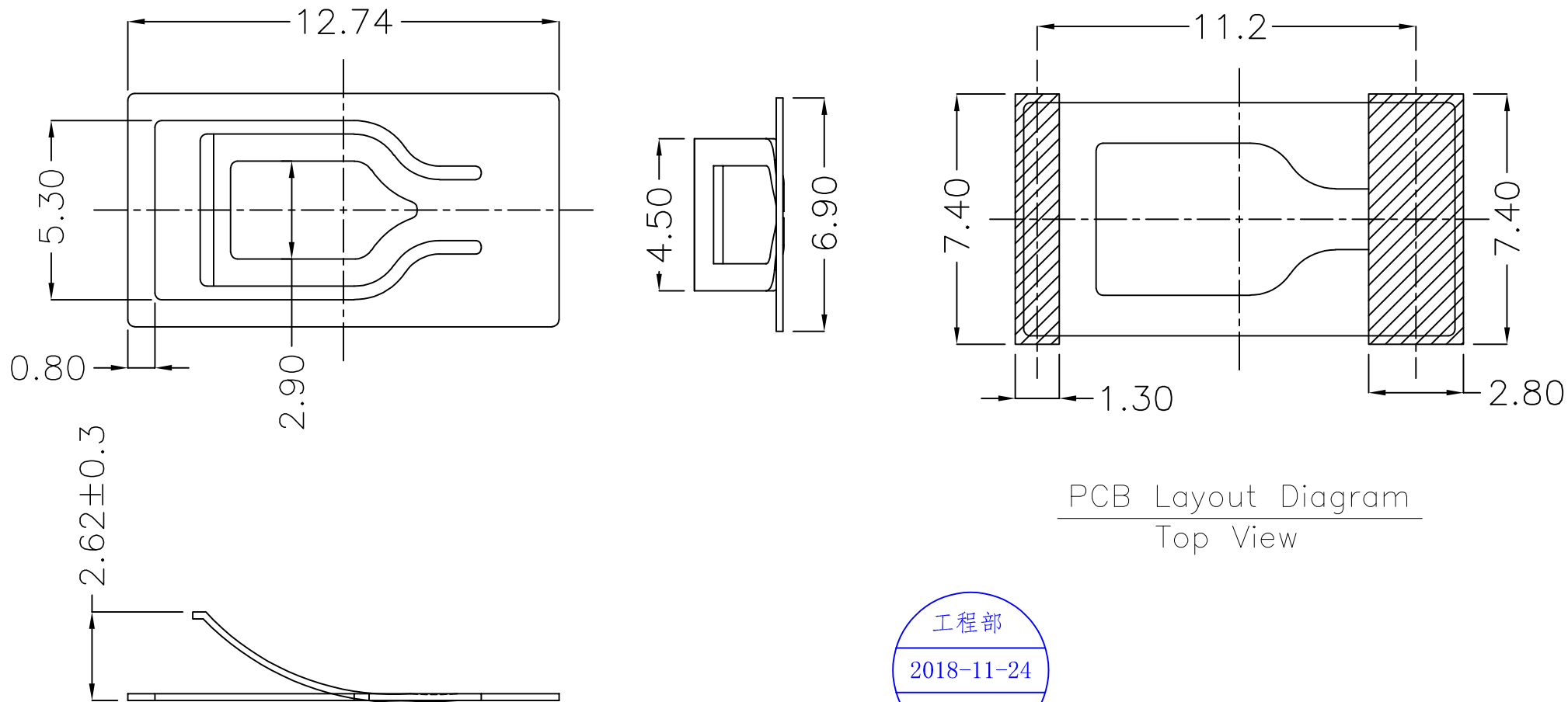

REV.	ECN NO.	REVISED	DATE



工程部  
2018-11-24  
H. WANG

技术要求:

- 1、截剪断面毛刺高度 $\leq 0.03\text{mm}$ ;
- 2、部件要求平整,无变形、裂纹、损伤等外观缺陷;

UNLESS OTHERWISE SPECIFIED TOLERANCES		<b>MYOUNG 美用</b> <a href="http://www.meiyangdz.com">www.meiyangdz.com</a>	
DECIMALS: X :±0.30 X.X :±0.25 X.XX :±0.20 X.XXX :±0.10	ANGLES: X :±1° X.X :±0.5°	DSND WangHeng	DATE 2018-11-24
		CHKD ZhouRuicai	DATE 2018-11-24
		APVD XueShunong	DATE 2018-11-24
WEIGHT:		SCALE: 1:1	SIZE: A4
SHEET 1 OF 2		VIEW:	TITLE: 电池接触片-115负极 SMT 卷装
		UNIT: mm	REV.: A/0
		OBJECT: MY	PART NO.: MY-FJ-115-R
			DRAW NO.:MY-CP-0170

1	TERMINAL -	1	PHOSPHOR BRONZE, T=0.20mm	Au or Ni-Plating
NO.	PART NAME	Q'TY	MATERIAL	PLATING & COLOR

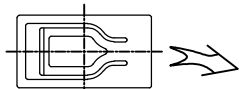

产品

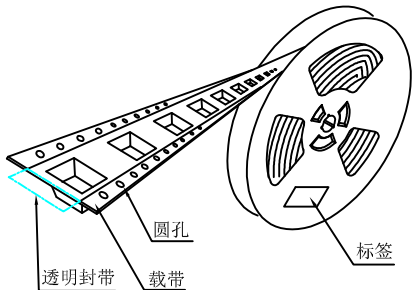

圆孔

透明封带 载带

标签

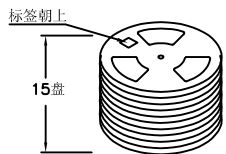

标签朝上

15盘

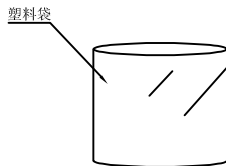

塑料袋

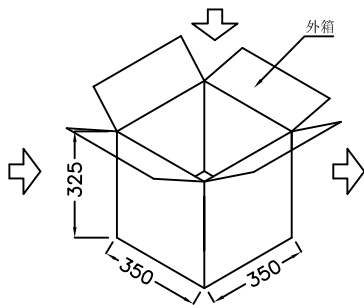

外箱

325

350

350

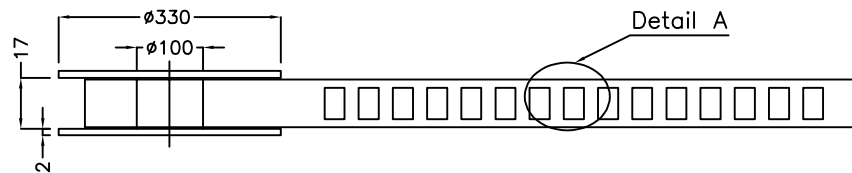
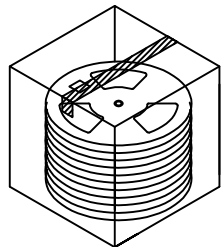

Detail A

17

Ø330

Ø100

2

出料方向

余留封带长: 200 MIN  
载带与封带剥离  
剥离角度: 165°-180°  
剥离强度: 0.1-1.0N

剥离方向

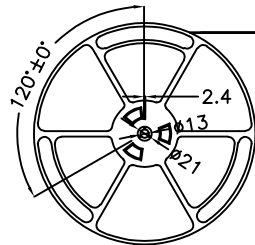

120°±0°

2.4

Ø13

Ø21

14空穴 共封装 1500 只产品

14空穴 前端留空穴载带

200MIN

末端留空穴载带

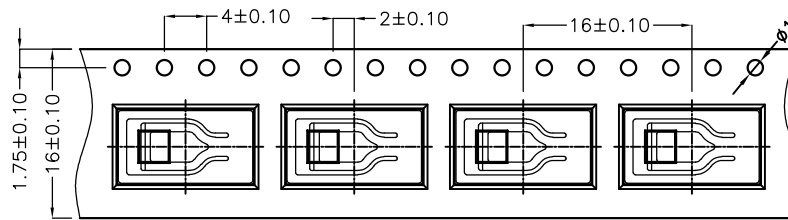

4±0.10 2±0.10 16±0.10

1.75±0.10 16±0.10

Ø1.50±0.10  
0.00

2.7±0.10

0.3±0.05

7.1±0.10



Detail A



工程部

2022-08-06

H. WANG

技术要求:

1. 圆孔十个孔距累计允许公差为±0.2mm
2. 带长250mm内容许弯曲度1mm
3. 材料厚度以在载带边缘测量为准
4. 所有尺寸定义依循EIA-481-C系准则定义之
5. 材料: 黑色PS T=0.30±0.05mm
6. 所有卷轮为灰蓝挖空旋转塑胶卷轮
7. 整模成型长度: 24.48M,
8. 非指明公差范围为: ±0.1mm; 超过250mm 不计算累计误差
9. 型腔外形凡未标明处倒角R为0.2-0.3; 拔模斜度未标注的为3° 以下

包装信息:

- 1、每卷盘装产品1500 只, 卷盘外侧贴相关标签;
- 2、每 15 卷盘放在一个塑料袋中;
- 3、每外箱装15盘, 产品总数: 22500 只;
- 4、外箱上下用胶纸封成"工"字;
- 5、电池接触片包材-115 SMT 卷装 (MY-FJ-115-R)

UNLESS OTHERWISE SPECIFIED TOLERANCES		<b>MYOUNG 美阳</b> www.meiyangdz.com					
DECIMALS: X.X: ±*** X.XX: ±*** X.XXX: ±***	ANGLES: X.X: ±*** X.XX: ±*** X.XXX: ±***	DSND	WangHeng	DATE	2022-08-06	TITLE:	电池接触片-115负极 SMT 卷装
		CHKD	ZhouRuicai	DATE	2022-08-06	PART NO.:	MY-FJ-115-R
		APVD	XueShunYong	DATE	2022-08-06	OBJECT:	MY
WEIGHT:		SCALE:	1:1	SIZE:	A4	REV.:	A/0
SHEET 2 OF 2		UNIT:	mm	OBJECT:	MY	DRAW NO.:	MY-BD-0031