

PART NUMBER	SML-LX2835SISUGUBC	REV.	C
DATE	E.C.N. NUMBER AND REVISION COMMENTS		REV.
03.14.11	E.C.N. #11699.		A
1.18.12	E.C.N. #11798.		B
09.17.14	E.C.N. #11927.		C

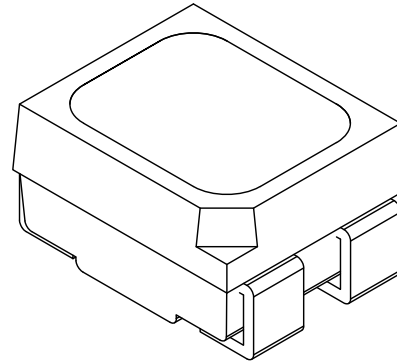
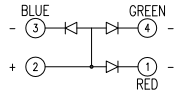
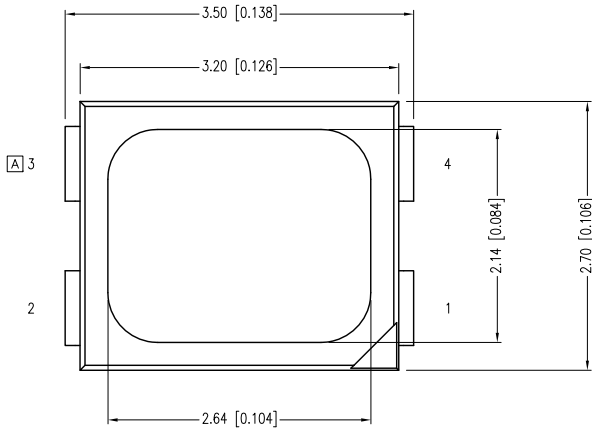

ELECTRO-OPTICAL CHARACTERISTICS $T_A=25^{\circ}\text{C}$ $I_f=20\text{mA}$

PARAMETER	RED	GREEN	BLUE	UNITS	TEST COND
PEAK WAVELENGTH	632	575	468	nm	
FORWARD VOLTAGE MIN.	1.75	1.75	2.75	V_f	
FORWARD VOLTAGE MAX.	2.35	2.35	3.65		
REVERSE VOLTAGE	5.0	5.0	5.0	V_r	$I_f=100\mu\text{A}$
AXIAL INTENSITY MIN.	72	28	90	mcd	$I_f=20\text{mA}$
AXIAL INTENSITY MAX.	180	72	225	mcd	$I_f=20\text{mA}$
VIEWING ANGLE	120	120	120	2x theta	
EMITTED COLOR:	RED/GREEN/BLUE				
EPOXY LENS FINISH:	WATER CLEAR LENS				

LIMITS OF SAFE OPERATION AT 25°C PER CHIP

PARAMETER	COLORS	MAX	UNITS
PEAK FORWARD CURRENT*	(R/G/B)	60/60/100	mA
STEADY CURRENT		25	mA
POWER DISSIPATION	(R/G/B)	60/60/95	mW
OPERATING TEMP.		-40 TO +85	°C
STORAGE TEMP.		-40 TO +90	°C
SOLDERING TEMP.		+260	°C
2.0mm FROM BODY			3 SEC. MAX

* $t < 10\mu\text{s}$

NOTES:

1. THE POLARITY MARK IS ORIENTED TOWARDS THE TAPE SPROCKET HOLE.
2. 2,000 PER REEL.

CAUTION: MOISTURE SENSITIVE DEVICE
PER JEDEC LEVEL 2 STANDARDS

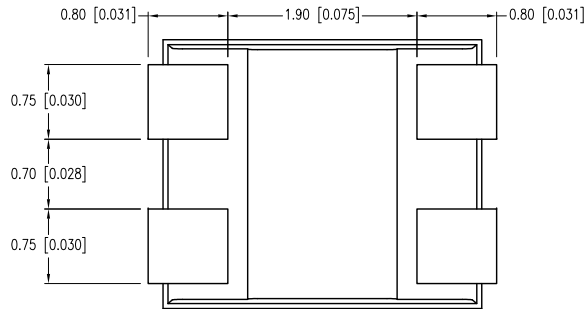
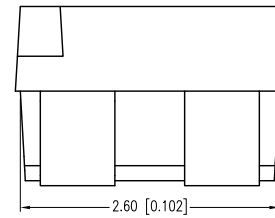
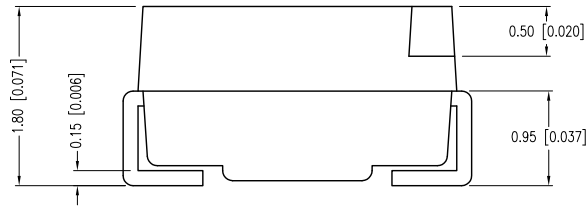

*UNLESS OTHERWISE SPECIFIED TOLERANCES PER DECIMAL PRECISION ARE: X=±1 (±0.039), X.X=±0.5 (±0.020), X.XX=±0.25 (±0.010), X.XXX=±0.127 (±0.005). LEAD SIZE=±0.05 (±0.002), LEAD LENGTH=±0.75 (±0.030). MIN= ^{+DECIMAL PRECISION} -0.00 _{-DECIMAL PRECISION}



290 E. HELEN ROAD
PALATINE, IL 60067-6976
PHONE: +1.847.359.2790
FAX: +1.847.359.6538
WEB: WWW.LUMEX.COM

2.7mm x 3.2mm SML /W REFLECTOR CUP, 632nm/575nm/468nm LED, WATER CLEAR LENS, 2k PER REEL.

THE SPECIFICATIONS MAY CHANGE AT ANY TIME WITHOUT NOTICE DUE TO NEW MATERIALS OR PRODUCT IMPROVEMENT.

CONFIDENTIAL INFORMATION
THE INFORMATION CONTAINED IN THIS DOCUMENT IS THE PROPERTY OF LUMEX INC. EXCEPT AS SPECIFICALLY AUTHORIZED IN WRITING BY LUMEX INC., THE HOLDER OF THIS DOCUMENT SHALL KEEP ALL INFORMATION CONTAINED HEREIN CONFIDENTIAL AND SHALL PROTECT SAME IN WHOLE OR IN PART FROM DISCLOSURE AND DISSEMINATION TO ALL THIRD PARTIES.

DATE:	02.03.11	DRAWN BY:	AB
PAGE:	1 OF 2	CHKD BY:	KF
SCALE:	NTS	APRVD BY:	SS
UNIT:	mm [INCH]		(Pb)

PART NUMBER	SML-LX2835SISUGUBC	REV.	C
DATE	E.C.N. NUMBER AND REVISION COMMENTS		REV.
03.14.11	E.C.N. #11699.		A
1.18.12	E.C.N. #11798.		B
09.17.14	E.C.N. #11927.		C

LEAD FREE REFLOW PROFILE

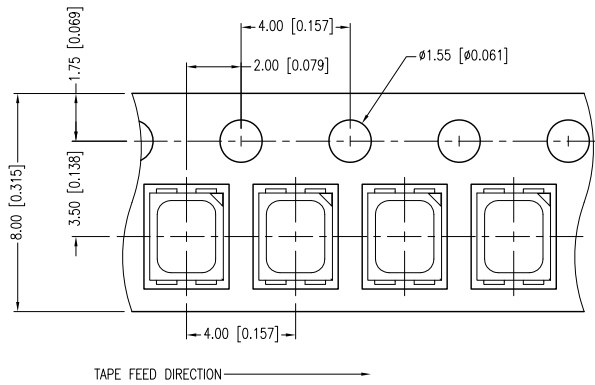
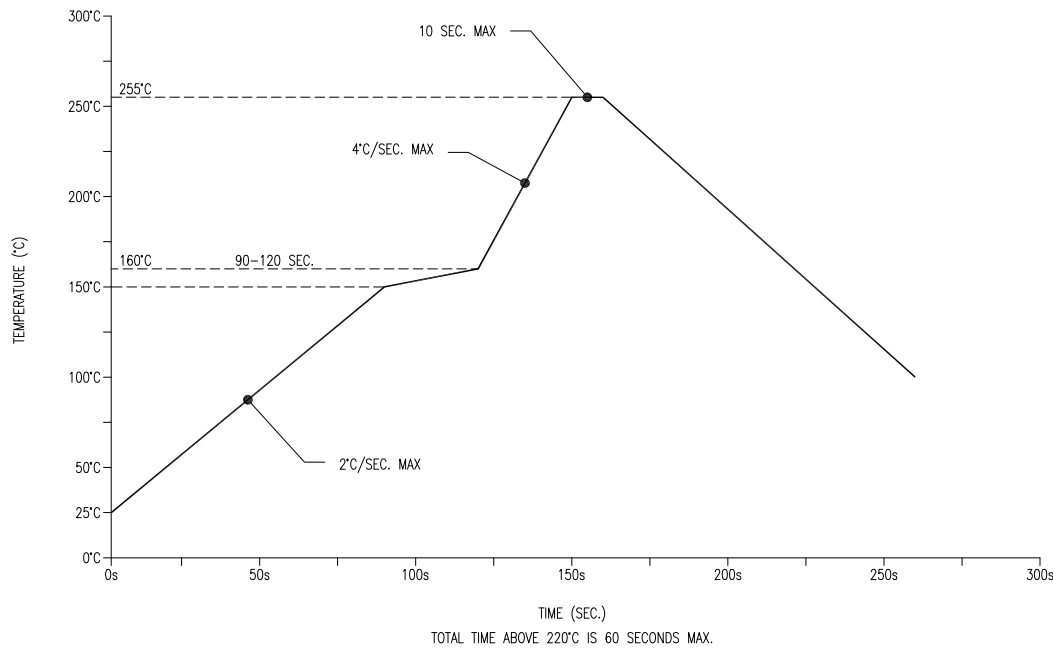

RECOMMENDED SOLDER PAD LAYOUT

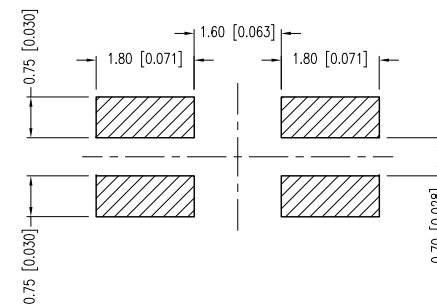

*UNLESS OTHERWISE SPECIFIED TOLERANCES PER DECIMAL PRECISION ARE: X=±1 (±0.039), X.X=±0.5 (±0.020), X.XX=±0.25 (±0.010), X.XXX=±0.127 (±0.005). LEAD SIZE=±0.05 (±0.002), LEAD LENGTH=±0.75 (±0.030). MIN.= ^{+0.00}DECIMAL PRECISION _{-0.00}DECIMAL PRECISION



290 E. HELEN ROAD
PALATINE, IL 60067-6976
PHONE: +1.847.359.2790
FAX: +1.847.359.6538
WEB: WWW.LUMEX.COM

2.7mm x 3.2mm SML /W REFLECTOR CUP, 632nm/575nm/468nm LED, WATER CLEAR LENS, 2k PER REEL.

THE SPECIFICATIONS MAY CHANGE AT ANY TIME WITHOUT NOTICE DUE TO NEW MATERIALS OR PRODUCT IMPROVEMENT.

CONFIDENTIAL INFORMATION
THE INFORMATION CONTAINED IN THIS DOCUMENT IS THE PROPERTY OF LUMEX INC. EXCEPT AS SPECIFICALLY AUTHORIZED IN WRITING BY LUMEX INC., THE HOLDER OF THIS DOCUMENT SHALL KEEP ALL INFORMATION CONTAINED HEREIN CONFIDENTIAL AND SHALL PROTECT SAME IN WHOLE OR IN PART FROM DISCLOSURE AND DISSEMINATION TO ALL THIRD PARTIES.

DATE:	02.03.11	DRAWN BY:	AB
PAGE:	2 OF 2	CHKD BY:	KF
SCALE:	NTS	APRVD BY:	SS
UNIT:	mm [INCH]		Ⓟ