

修 订 REV NO	标 记 MARK	修 改 描 要 REVISION DESCRIPTION	签 名 SIGNATURE	日 期 DATE
		NEW DWG		2016-03-12

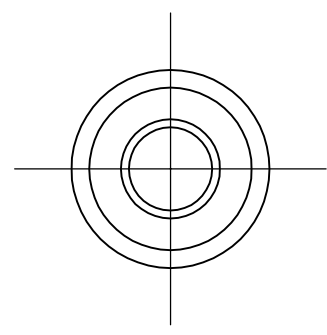

NOTE:

- ELECTRICAL REQUIREMENTS?
 - DIELECTRIC STRENGTH? AC 650V AT 1 MINUTE?
 - INSULATION RESISTANCE? DC 500V/100MEG OHMS MIN?
 - CONTACT RESISTANCE? 30MILLIOHMS MAX OR LESS BETWEEN PLUG AND JACK?
- MECHANICAL CHARACTERISTICS?
 - INSERTION FORCE? 15N MIN?
 - WITHDRAWAL FORCE? 13N MIN?
- SALT SPRAY? 35+/-2? 95-98%(R.H.) PH? 6.5-7.2, 24 HOURS

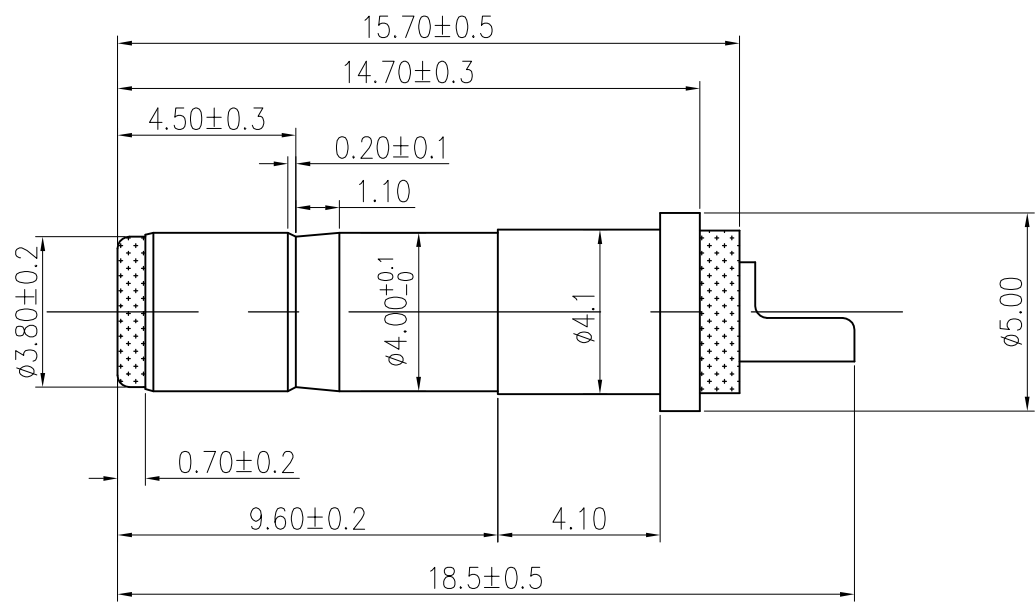
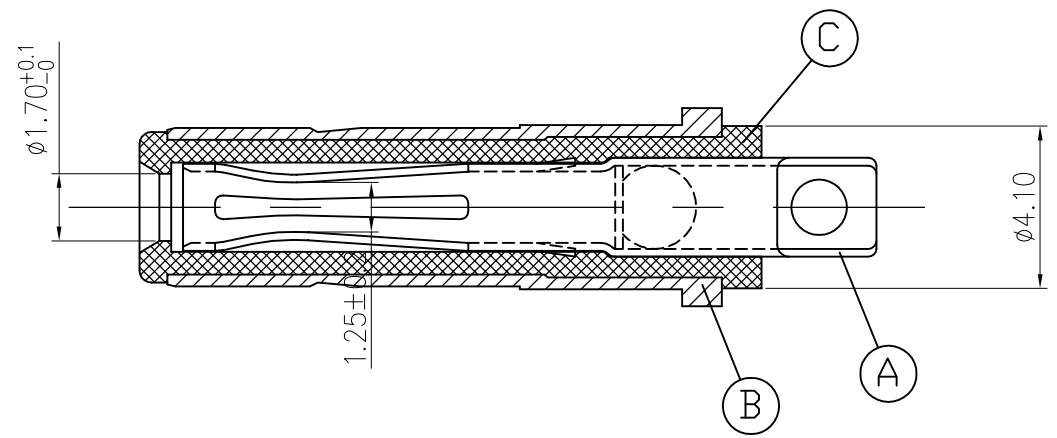

ITEM	DESCRIPTION	MATERIAL	TREATMENT	Q'TY
C	INSULATOR	PBT, 94V-0	COLOR:BLACK	1
B	OUTER BARREL	BRASS	NICKEL	1
A	FORK CONTACT	PHOSPHOR BRONZE	NICKEL	1

HDCG 深圳市华德共创科技有限公司
 Shenzhen Huade co-create Technology Co.,LTD
 电话: 0755-27111216 传真: 0755-29940187

NO	MATERIAL	PLATING	THICKNESS
3	P-BRONZE	NICKEL	2um
2	BRASS	NICKEL	2um
1	PBT	BLACK	

-TOLERANCES- UNLESS OTHERWISE SPECIFIED 公差参数表		APPD: 核准:		TITLE: 产品名称: DC电源插头 $\phi 4.00 \times \phi 1.70$			
X.X	± 0.30	X.X*	$\pm 3^\circ$	PART NO: 产品编号: DP400170-0038-6H			
X.XX	± 0.20	X.XX*	$\pm 2^\circ$	CHECK: 校对: 王建业	DATE	SCALE	UNIT
X.XXX	± 0.10	X.XXX*	$\pm 1^\circ$	DRAW: 绘图: 黄艳兰	2016-03-12	1:1	mm
							CODE NUMBER A001