

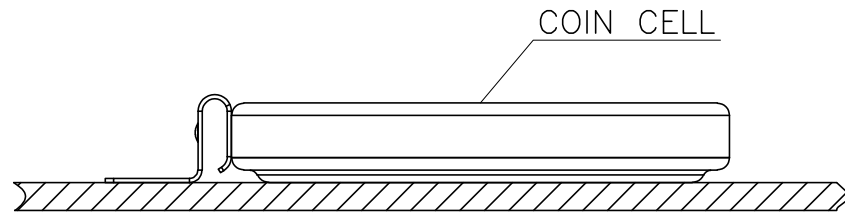

REV.	ECN NO.	REVISED	DATE

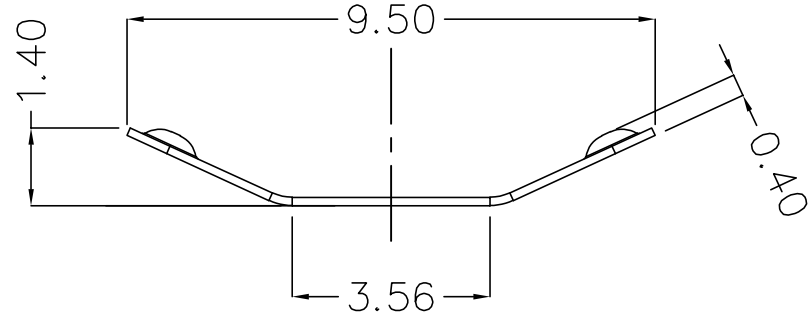
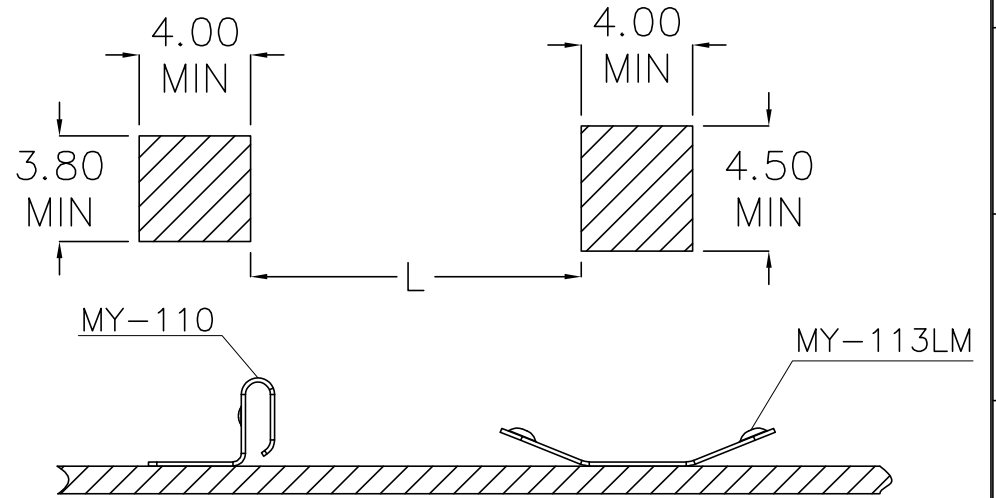
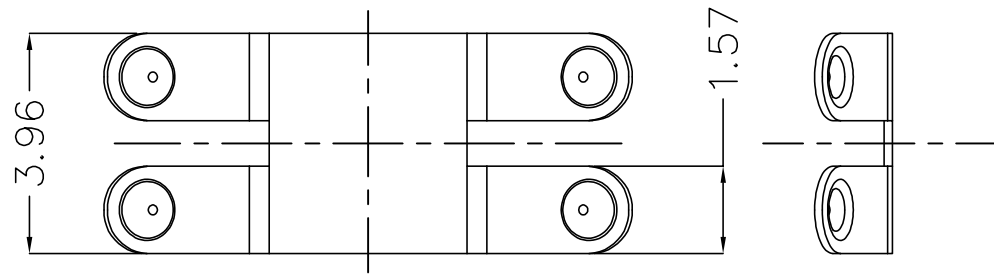

S:2:1

MTG LAYOUT USE WITH MY-113LM

COIN CELL DIA.	LDM.
20MM	9.40
23MM	10.90
24MM	11.40
30MM	14.40

工程部
2025-08-30
H. WANG

UNLESS OTHERWISE SPECIFIED TOLERANCES		MYOUNG 美用 www.meiyangdz.com	
DECIMALS: X :±0.30 X.X :±0.25 X.XX :±0.20 X.XXX :±0.10	ANGLES: X :±2° X.X :±1°	DSND WangHeng	DATE 2025-08-30
A-PD		CHKD ZhouRuicai	DATE 2025-08-30
		APVD XueShunyong	DATE 2025-08-30
SHEET 1 OF 2		SCALE: 1:1	SIZE: A4
UNIT: mm		REV.: A/0	VIEW:
TITLE:		PART NO.:	
		MY-FJ-113LM-R	
DRAW NO.:MY-CP-0136			

1	TERMINAL(-)	1	STAINLESS STEEL T=0.15mm	Au-Plating
NO.	PART NAME	Q'TY	MATERIAL	PLATING & COLOR

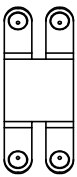

product

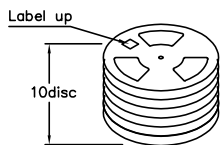
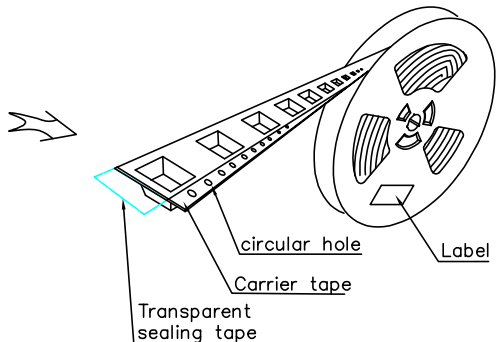

10disc

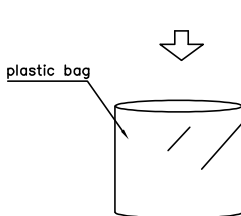

plastic bag

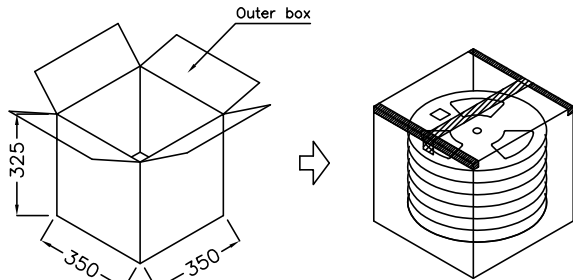

Outer box

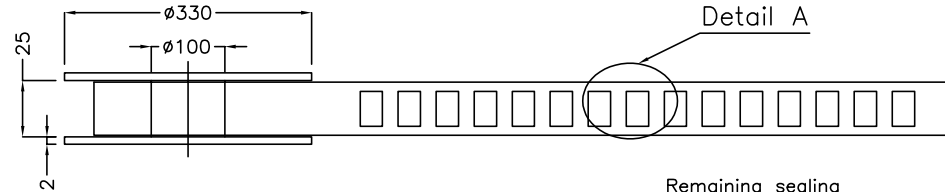

Detail A

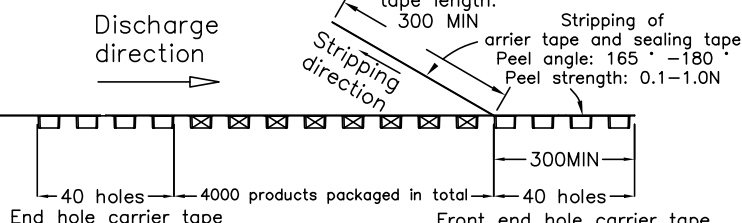
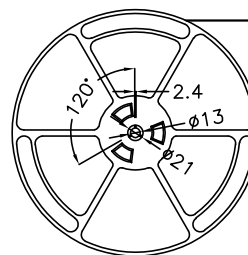

Discharge direction

Remaining sealing tape length: 300 MIN
Stripping of carrier tape and sealing tape
Peel angle: 165° - 180°
Peel strength: 0.1-1.0N

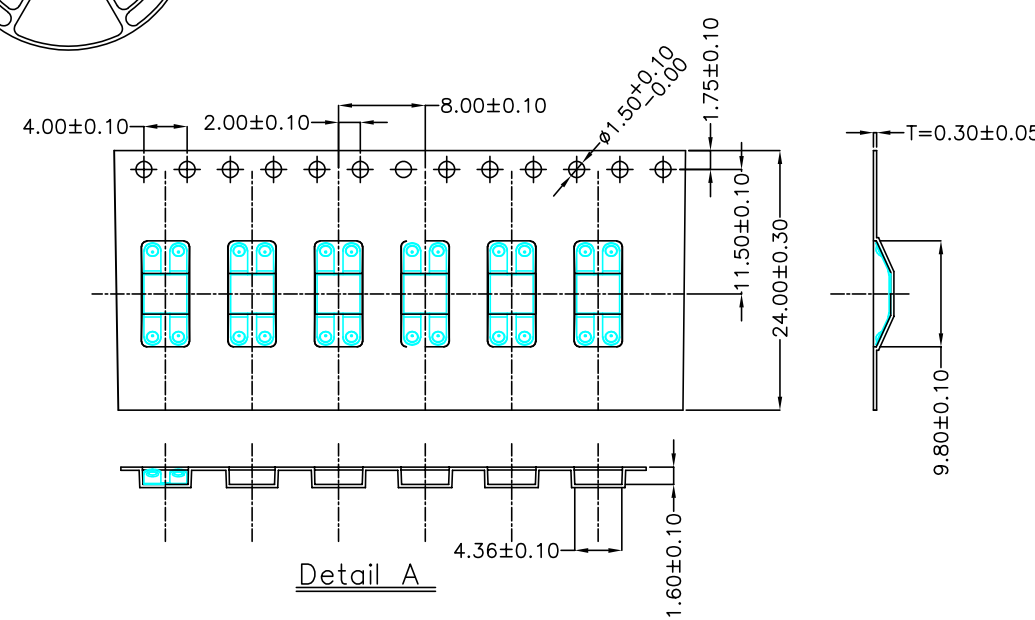

Detail A

Packaging information:

1. Each roll contains 4000 products, with relevant labels attached to the outside of the roll;
2. Put every 10 rolls in a plastic bag;
3. Each outer box contains 10 plates, with a total of 40000 products;
4. Seal the top and bottom of the outer box with adhesive tape to form the character "工";
5. Battery shrapnel packaging material 113 SMT roll pack(MY-FJ-113-01-R).

工程
2025-08-30
H. WANG

UNLESS OTHERWISE SPECIFIED TOLERANCES		MYOUNG 美用 www.meiyangdz.com			
DECIMALS: X :±*** X.X :±*** X.XX :±*** X.XXX :±***	ANGLES: X :±*** X.X :±***	DSND WangHeng	DATE 2025-08-30	TITLE: 电池接触片-113LM负极 卷装	
A-PD		CHKD ZhouRuicai	DATE 2025-08-30	PART NO.: MY-FJ-113LM-R	
SHEET 2 OF 2		APVD XueShun Yong	DATE 2025-08-30	DRAW NO.:MY-BD-0020	
		SCALE:	SIZE: A4	VIEW:	
		UNIT: mm	REV.: A/0	OBJECT: MY	