

BT134
MAIN FEATURES 4Q TRIAC

Symbol	Value	Unit
$I_{T(RMS)}$	2	A
V_{DRM}/V_{RRM}	800	V
$I_{GT1/2/3/4}$	5/5/5/10	mA

DESCRIPTION:

The BT134 triac is suitable for general purpose AC switching. It can be used as an ON/OFF function in applications such as heating regulation, induction motor starting circuits, for phase control operation in light dimmers, motor speed controllers.

Package SOT-223-3L is RoHS compliant.

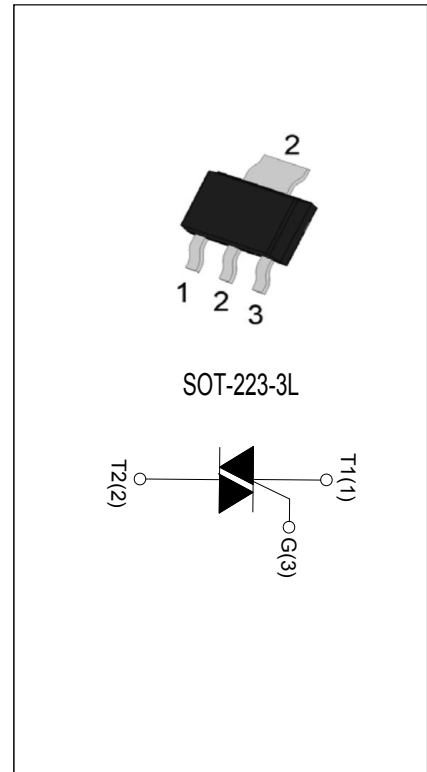
ABSOLUTE MAXIMUM RATINGS

Parameter	Symbol	Value	Unit
Storage junction temperature range	T_{stg}	-40-150	°C
Operating junction temperature range	T_j	+125	°C
Repetitive peak off-state voltage ($T_j=25^\circ\text{C}$)	V_{DRM}	800	V
Repetitive peak reverse voltage ($T_j=25^\circ\text{C}$)	V_{RRM}	800	V
RMS on-state current ($T_c \leq 90^\circ\text{C}$)	$I_{T(RMS)}$	2	A
Non repetitive surge peak on-state current (full cycle , $t_p=20\text{ms}$, $T_j=25^\circ\text{C}$)	I_{TSM}	20	A
I^2t value for fusing ($t_p=10\text{ms}$, $T_j=25^\circ\text{C}$)	I^2t	2.6	A^2s
Critical rate of rise of on-state current ($T_j=125^\circ\text{C}$)	di/dt	50	$\text{A}/\mu\text{s}$
Peak gate current ($t_p=20\mu\text{s}$, $T_j=125^\circ\text{C}$)	I_{GM}	2	A
Average gate power dissipation ($T_j=125^\circ\text{C}$)	$P_{G(AV)}$	0.5	W

ELECTRICAL CHARACTERISTICS ($T_j=25^{\circ}\text{C}$ unless otherwise specified)

Symbol	Test Condition	Quadrant	Value		Unit
I_{GT}	$V_D=12\text{V}$ $R_L=100\Omega$	I - II - III	MAX.	5	mA
		IV		10	
V_{GT}		ALL	MAX.	1.5	V
V_{GD}	$V_D=V_{DRM}$ $T_j=125^{\circ}\text{C}$ $R_L=100\Omega$	ALL	MIN.	0.2	V
I_L	$I_G=1.2I_{GT}$	I - III - IV	MAX.	15	mA
		II		30	
I_H	$I_T=500\text{mA}$		MAX.	15	mA
dV/dt	$V_D=2/3V_{DRM}$ $T_j=125^{\circ}\text{C}$		MIN.	5	V/ μs
dV/dt	$T_j=125^{\circ}\text{C}$		MIN.	10	V/ μs

STATIC CHARACTERISTICS

Symbol	Parameter		Value(MAX.)	Unit
V_{TM}	$I_{TM}=5\text{A}$	$T_j=25^{\circ}\text{C}$	1.7	V
V_{TO}	Threshold voltage	$T_j=125^{\circ}\text{C}$	0.94	V
R_D	Dynamic resistance	$T_j=125^{\circ}\text{C}$	36.8	m Ω
I_{DRM}	$V_D=V_{DRM}$ $V_R=V_{RRM}$	$T_j=25^{\circ}\text{C}$	5	μA
I_{RRM}		$T_j=125^{\circ}\text{C}$	1	mA

THERMAL RESISTANCES

Symbol	Parameter	Value	Unit
$R_{th(j-c)}$	junction to case (AC)	11.3	$^{\circ}\text{C}/\text{W}$

ORDERING INFORMATION

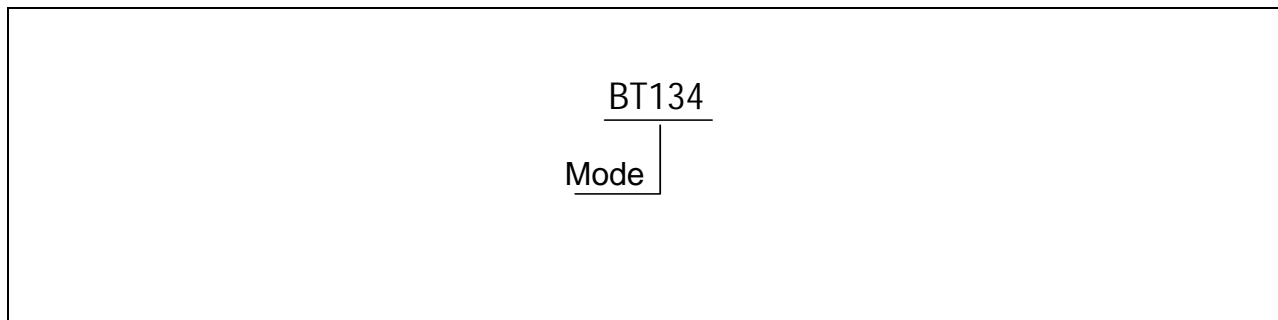

MARKING

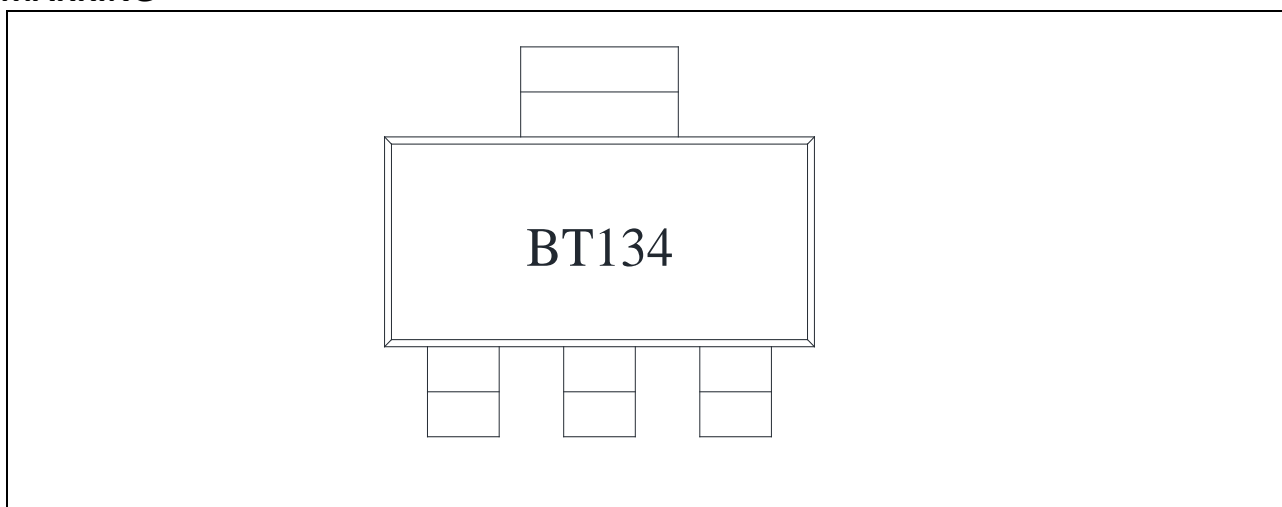

ORDERING INFORMATION

Order code	Voltage V _{DRM} /V _{RPM} (V)	IGT(mA)		Package	Base qty. (pcs)	Delivery mode
		I -II-III	IV			
BT134	800	5	10	SOT-223-3L	1000	REEL

PACKAGE MECHANICAL DATA

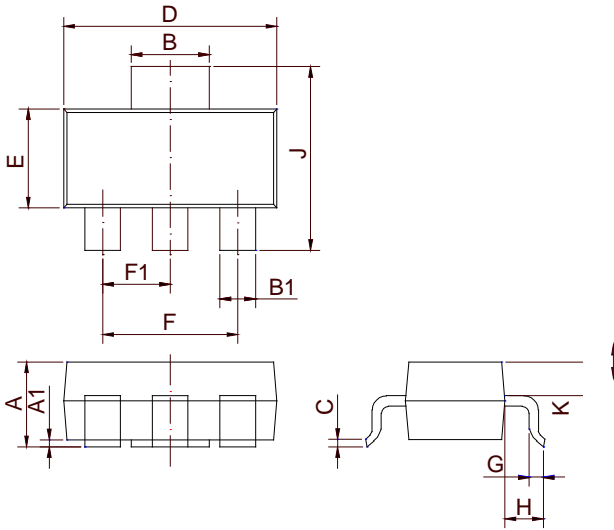

SOT-223-3L

Ref.	Dimensions		
	Millimeters		
	Min.	Typ.	Max.
A	1.5	1.6	1.8
A1	0.01	0.06	0.10
B	2.9	3.0	3.1
B1	0.6	0.7	0.8
C	0.22	0.26	0.32
D	6.3	6.5	6.7
E	3.3	3.5	3.7
F	4.4	/	4.8
F1	2.2	/	2.4
G	0.5	/	1.0
H	1.5	1.75	2.0
J	6.7	7.0	7.3
K	0.8	0.9	1.0

DELIVERY MODE

PACKAGE	OUTLINE	REEL (PCS)	INNER BOX (PCS)	PER CARTON (PCS)
SOT-223-3L	REEL	2.5K	5K	25K

FIG.1 Maximum power dissipation versus RMS state current

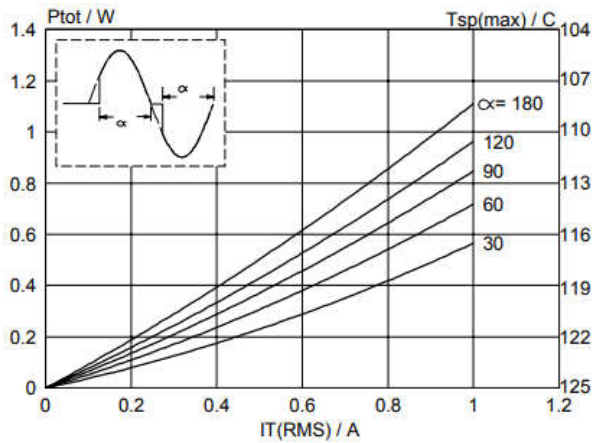

FIG.2: RMS on-state current versus case temperature

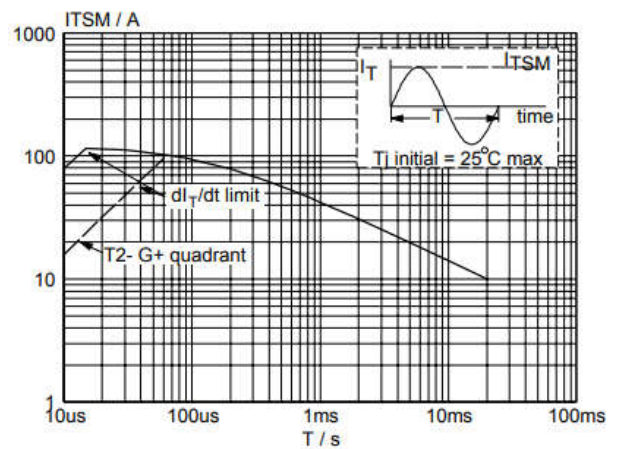

FIG.3: Surge peak on-state current versus

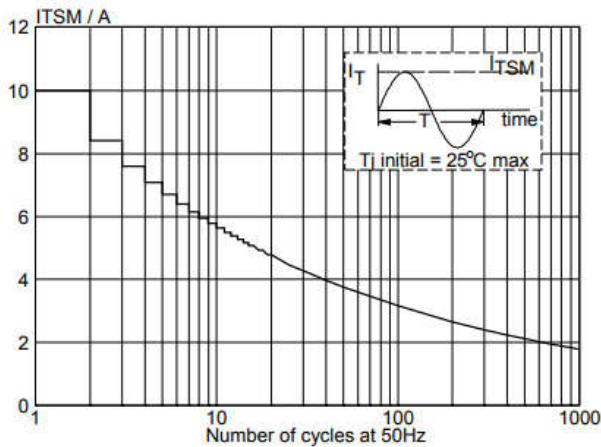

FIG.4: On-state characteristics

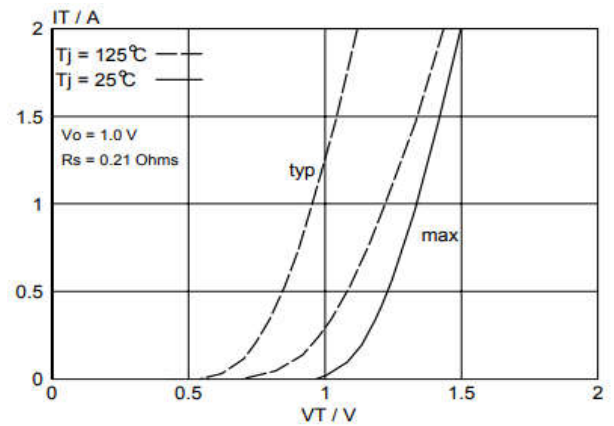

FIG.5: Non-repetitive surge peak on-state current for a sinusoidal pulse with width tp and value of It

(I II III dl/dt<50A/μs;IV: dl/dt<30A/μs)

FIG.6: Relative variations of gate trigger current, holding current and latching current versus junction temperature

