

Description

The TL432 is a Three-terminal adjustable shunt regulator highly accurate 1.24V bandgap reference. The device offers thermal stability, wide operating current and an extended temperature range of 0 to 105 °C for operation in power supply applications. The TL432 offers a wide operating voltage range of up to 18V and is an excellent choice for voltage reference requirements in an isolated feedback circuit for 3.0V to 3.3V switching mode power supplies.

Feature

- Wide programmable output voltage from 1.24V to 18V
- Sink current capability from 55μA to 100mA.
- Low output noise
- Wide Operating Range of -40 to 125°C

Application

- Adjustable voltage and current references
- Voltage monitoring
- Replacement of zener diode
- Comparator with integrated reference

Schematic diagram

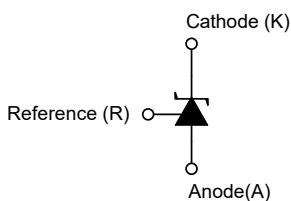

Functional block diagram

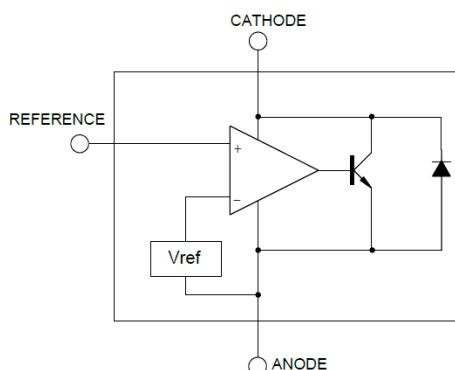

SOT-23

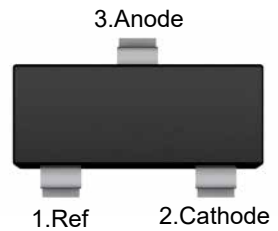

SOT-23-3

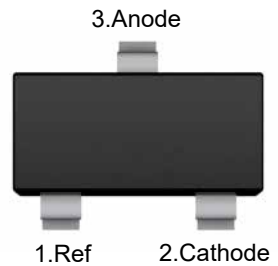

SOT-89

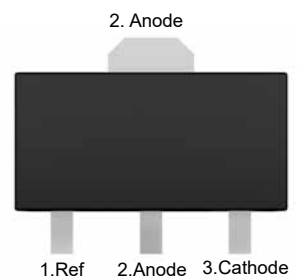

SOT-23-5

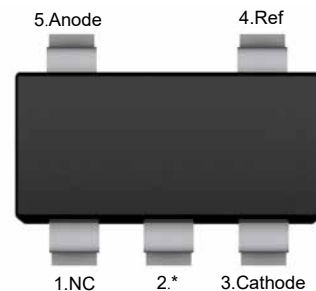

NC:No internal connection
*: Attached to substrate and must be connected to Anode or left open

SOP-8

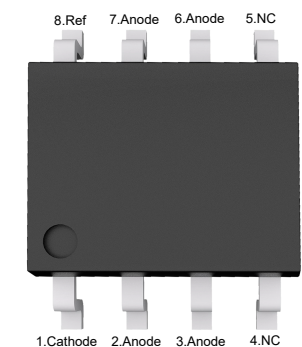

NC:No internal connection

**Ordering Information**

TL432-□ □

└ Package Type

□□(Blank): SOT-23

SC: SOT-23-3

SQ: SOT-89

SE: SOT-23-5

PA: SOP-8

└ V_{REF} tolerance

□(Blank): 1%

C: 0.5%

Orderable Device	Voltage Tolerance	Package	Reel (inch)	Package Qty (PCS)	Eco Plan ^{Note}	MSL Level	Marking Code
TL432	1%	SOT-23	7	3000	RoHS & Green	MSL1	432
TL432C	0.5%	SOT-23	7	3000	RoHS & Green	MSL1	432C
TL432SC	1%	SOT-23-3	7	3000	RoHS & Green	MSL3	T432
TL432CSC	0.5%	SOT-23-3	7	3000	RoHS & Green	MSL3	T432C
TL432SQ	1%	SOT-89	7 / 13	1000 / 3000	RoHS & Green	MSL1	TL432
TL432CSQ	0.5%	SOT-89	7 / 13	1000 / 3000	RoHS & Green	MSL1	TL432C
TL432SE	1%	SOT-23-5	7	3000	RoHS & Green	MSL3	432E
TL432CSE	0.5%	SOT-23-5	7	3000	RoHS & Green	MSL3	432CE
TL432PA	1%	SOP-8	13	4000	RoHS & Green	MSL3	432P
TL432CPA	0.5%	SOP-8	13	4000	RoHS & Green	MSL3	432CP

Note:

RoHS: PJ defines "RoHS" to mean semiconductor products that are compliant with the current EU RoHS requirements for all 10 RoHS substances, including the requirement that RoHS substance do not exceed 0.1% by weight in homogeneous materials.

Green: PJ defines "Green" to mean Halogen-Free and Antimony-Free.

**Absolute Maximum Ratings** ($T_a=25^{\circ}\text{C}$ unless otherwise specified)

Parameter	Symbol	Value	Units
Cathode Voltage	V_{KA}	20	V
Cathode Current Range(Continuous)	I_{KA}	-100 ~ +100	mA
Reference Input Current Range	I_{REF}	10	mA
Operating Junction Temperature	T_J	150	$^{\circ}\text{C}$
Storage Temperature Range	T_{STG}	-65 ~ +150	$^{\circ}\text{C}$

Note: Absolute maximum ratings are those values beyond which the device could be permanently damaged.
Absolute maximum ratings are stress ratings only and functional device operation is not implied.

Recommended Operating Conditions

Parameter	Symbol	Min.	Max.	Units
Cathode Voltage	V_{KA}	V_{REF}	18	V
Cathode Current	I_{KA}	0.1	100	mA
Operating Ambient Temperature Range	T_{OPR}	-40	125	$^{\circ}\text{C}$

Thermal Information

Parameter	Symbol	Value		Units
Junction-to-Ambient thermal resistance	$R_{\theta JA}$	SOT-23	416	$^{\circ}\text{C}/\text{W}$
		SOT-23-3	416	$^{\circ}\text{C}/\text{W}$
		SOT-23-5	416	$^{\circ}\text{C}/\text{W}$
		SOT-89	156	$^{\circ}\text{C}/\text{W}$
		SOP-8	208	$^{\circ}\text{C}/\text{W}$

Electrical Characteristics (Ta=25°C unless otherwise specified)

Parameter	Symbol	Test Conditions	Min.	Typ.	Max.	Unit	
Reference Input Voltage Fig1	V _{REF}	V _{KA} =V _{REF} , I _{KA} =10mA	TL432(1%)	1.228	1.24	1.252	V
			TL432C(0.5%)	1.234	1.24	1.246	V
Deviation of Reference Input Voltage Over Temperature Fig1	ΔV _{REF}	V _{KA} =V _{REF} , I _{KA} =10mA	0°C ≤ T _A ≤ 70°C	--	2	10	mV
			-20°C ≤ T _A ≤ 125°C	--	3	15	mV
			-40°C ≤ T _A ≤ 125°C	--	8	25	mV
Ratio of Change in Reference Input Voltage to The Change in Cathode Voltage Fig2	$\frac{\Delta V_{REF}}{\Delta V_{KA}}$	I _{KA} =10mA, ΔV _{KA} =V _{REF} ~16V	--	-0.5	-1.5	mV/V	
Reference Input Current Fig2	I _{REF}	I _{KA} =10mA, R1=10KΩ, R2=∞	--	0.15	0.4	μA	
Deviation of Reference Input Current Over Full Temperature Range Fig2	ΔI _{REF}	I _{KA} =10mA, R1=10KΩ, R2=∞, -20°C ≤ T _A ≤ +85°C	--	--	0.4	μA	
Minimum Cathode Current for Regulation Fig1	I _{KA(MIN)}	V _{KA} =V _{REF}	--	--	80	μA	
Off-State Cathode Current Fig3	I _{KA(OFF)}	V _{KA} =18V, V _{REF} =0	--	0.04	0.5	μA	
Dynamic Impedance	Z _{KA}	V _{KA} =V _{REF} , I _{KA} =1~100mA, f ≤ 1.0KHz	--	0.05	0.15	Ω	

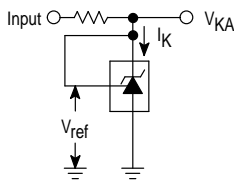
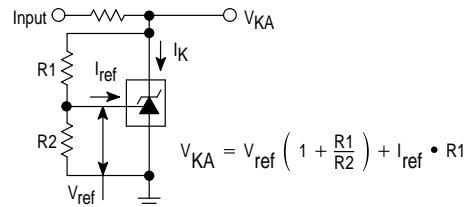
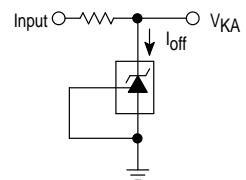
Figure 1. Test Circuit for V_{KA} = V_{REF}

Figure 2. Test Circuit for V_{KA} > V_{REF}

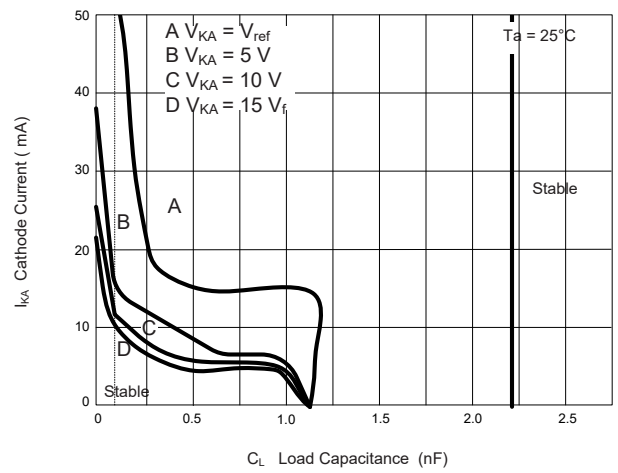
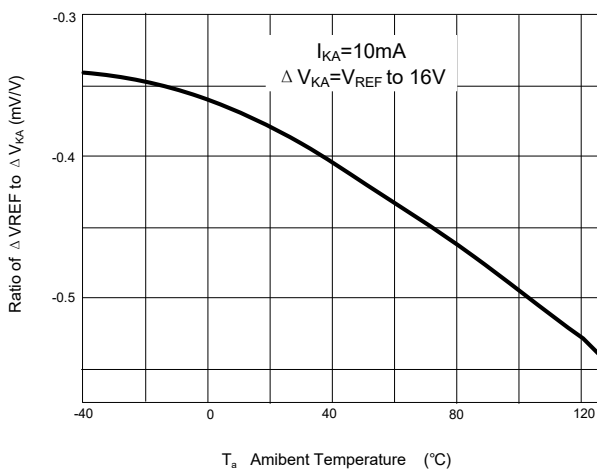
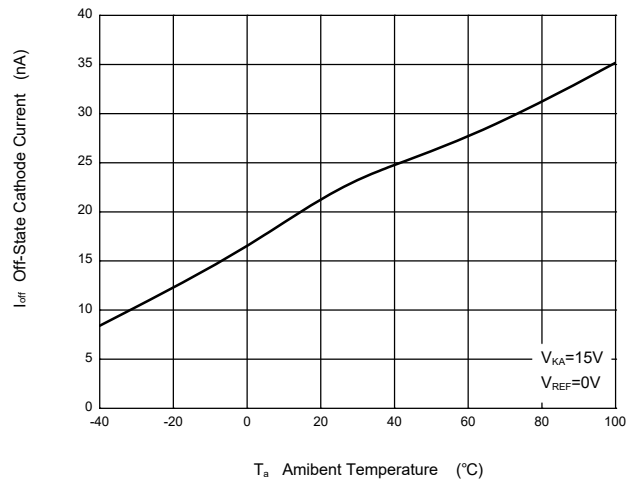
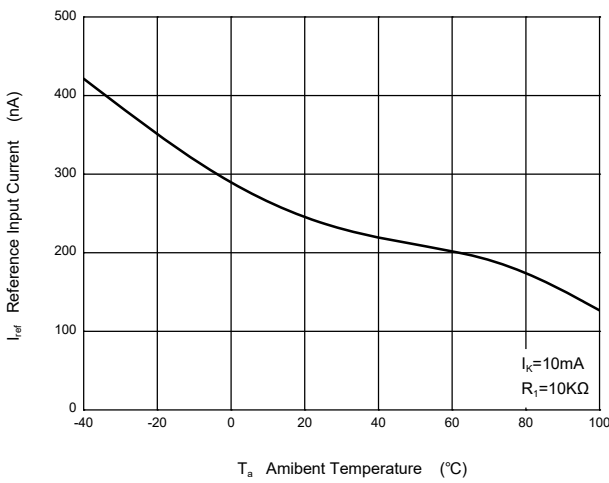
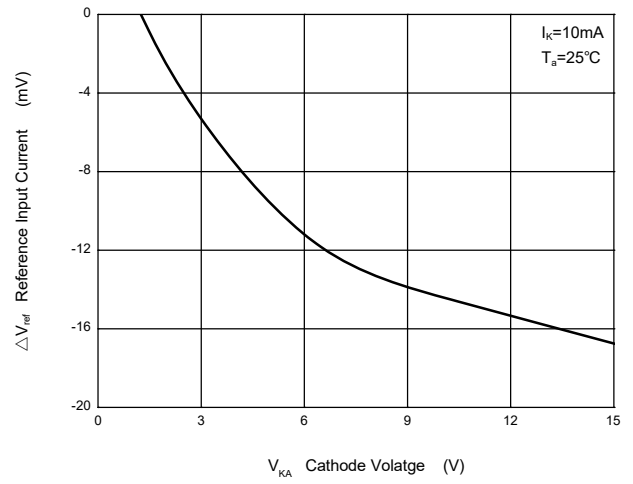
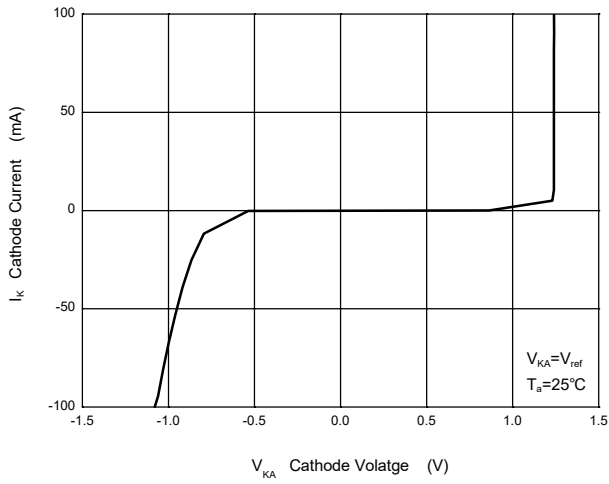
Figure 3. Test Circuit for I_{OFF}

Typical Characteristic Curves



Package Outline

SOT-23

Dimensions in mm

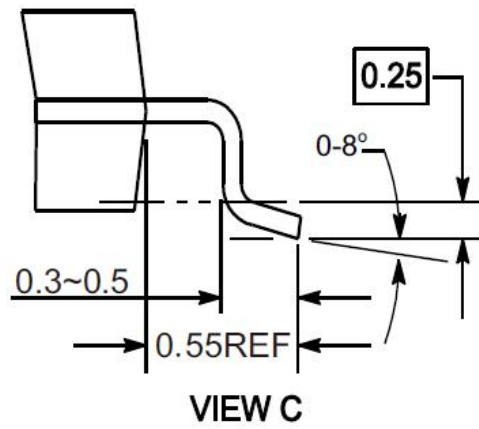
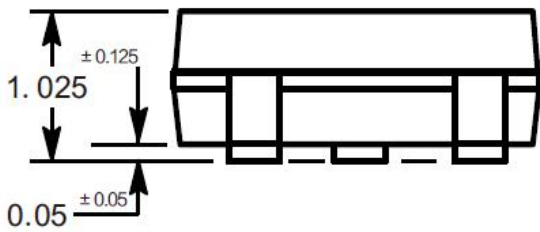
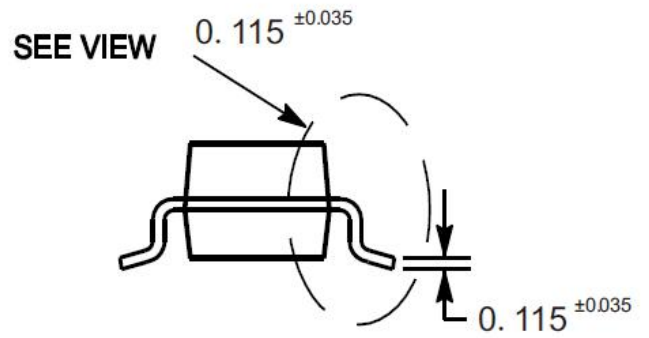
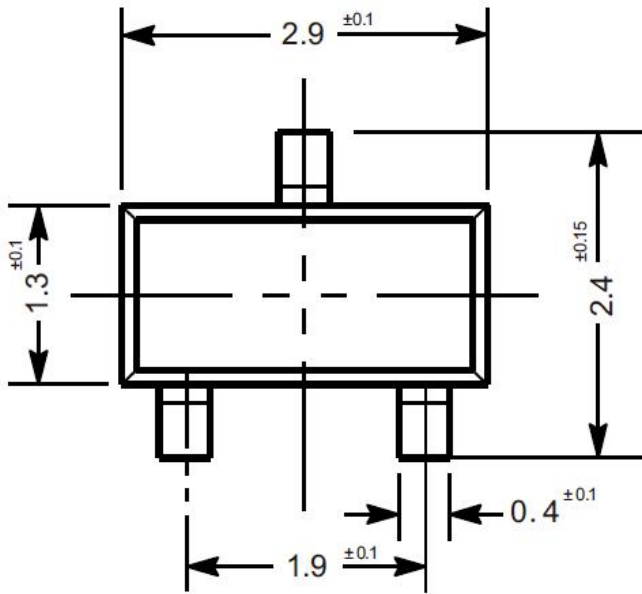

Package Outline

SOT-23-3

Dimensions in mm

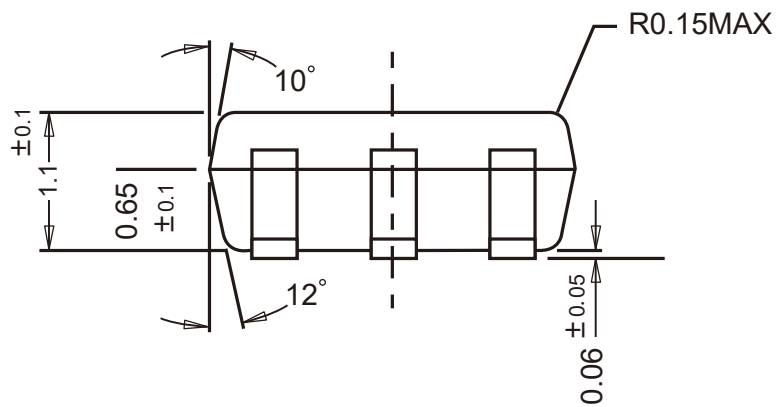
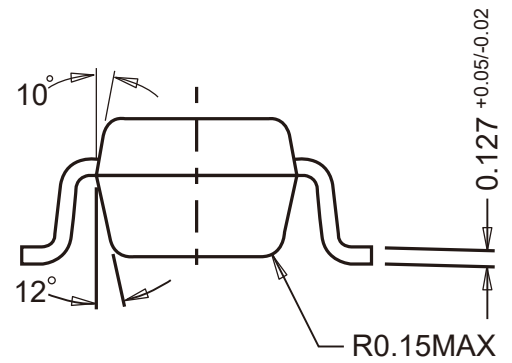
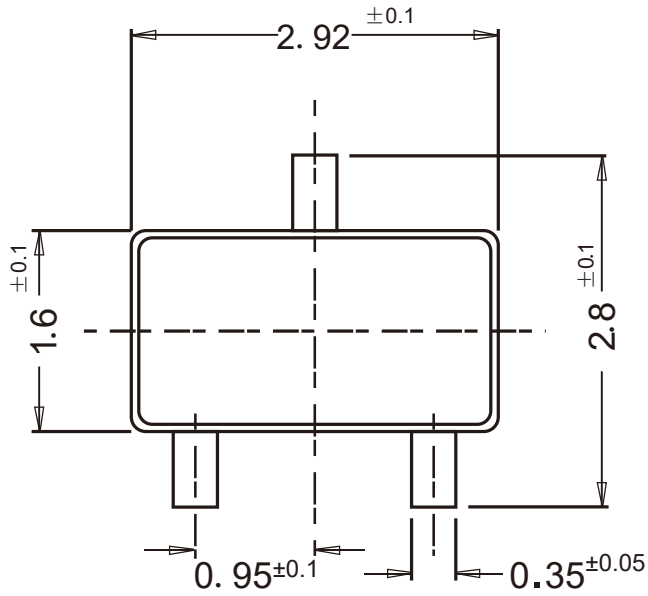

Package Outline

SOT-23-5

Dimensions in mm

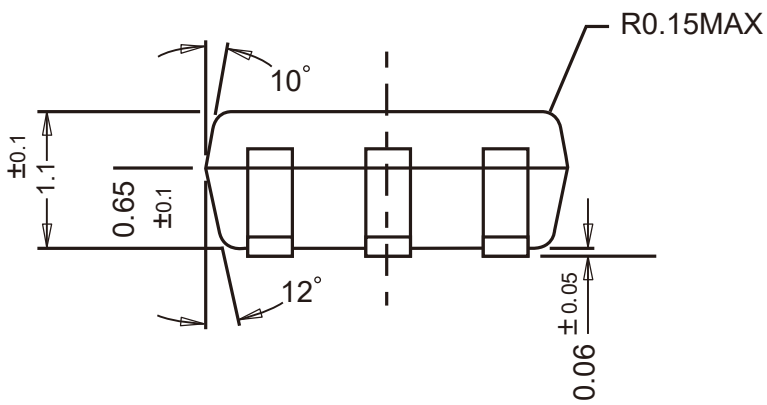
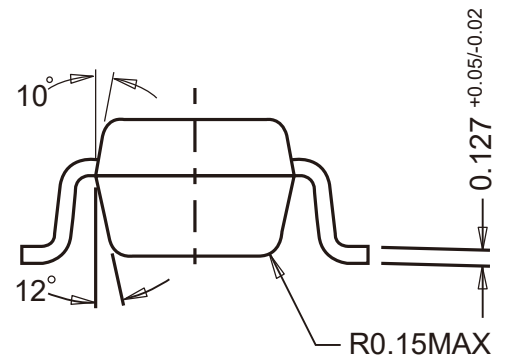
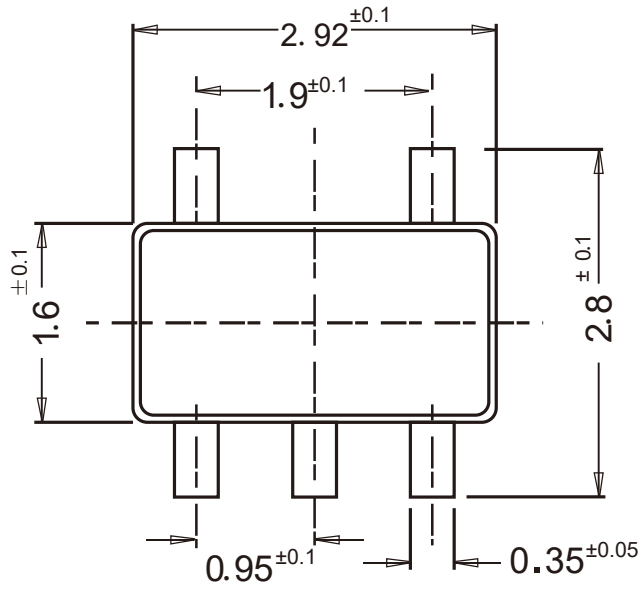

Package Outline

SOT-89

Dimensions in mm

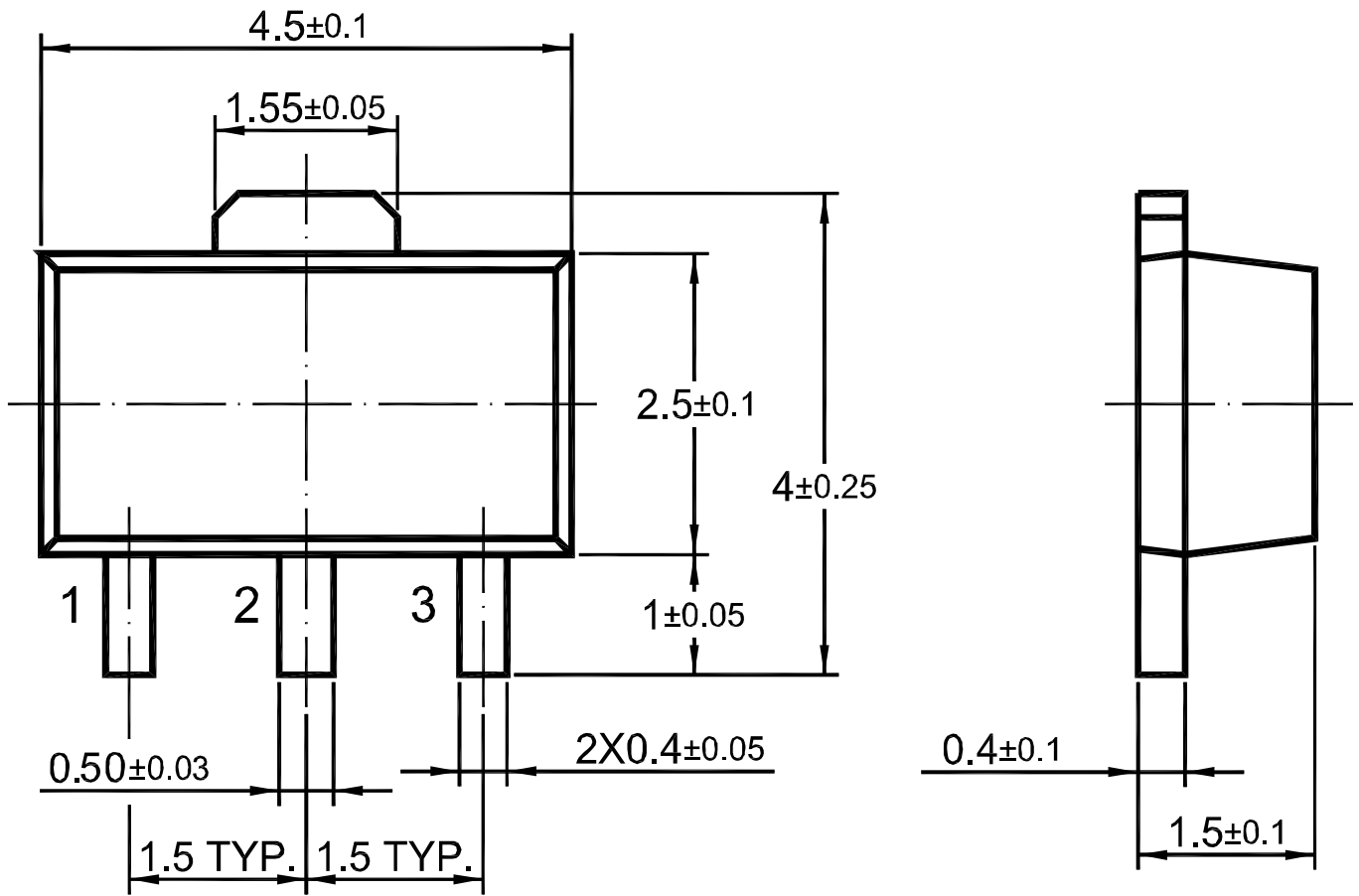

Package Outline

SOP-8

Dimensions in mm

