

### Features

- Ultra low forward voltage, low power loss
- Surface mount package
- Ultra thin profile package for space constrained utilization
- Lead free in compliance with EU RoHS 2.0
- Green molding compound as per IEC 61249 standard

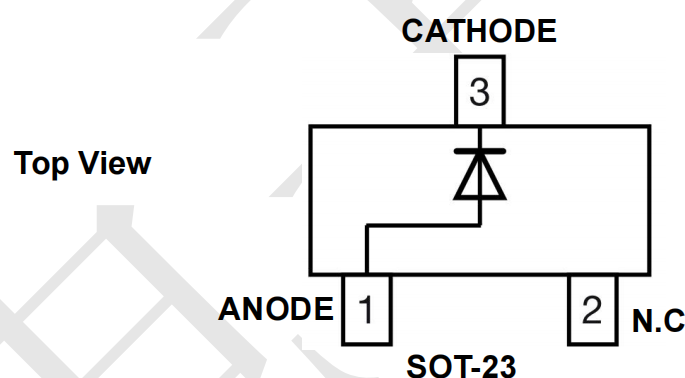
### Mechanical Data

- Case: Molded plastic, SOT-23
- Terminals: Solderable per MIL-STD-750, Method 2026
- Approx. Weight: 0.0003 ounces, 0.0084 grams

### Applications

- Low voltage rectification
- Reverse polarity protection
- Low power consumption applications

### Pin Configuration



### Maximum Ratings (T<sub>A</sub>= 25 °C unless otherwise noted)

PARAMETER	SYMBOL	TPMEG4005CT	UNIT
Maximum repetitive peak reverse voltage	V <sub>RRM</sub>	40	V
Maximum rms voltage	V <sub>RMS</sub>	28	V
Maximum dc blocking voltage	V <sub>R</sub>	40	V
Maximum average forward rectified current	I <sub>F(AV)</sub>	0.5	A
Peak forward surge current: 8.3ms single half sine-wave Superimposed on rated load	I <sub>FSM</sub>	2	A
Typical thermal resistance	R <sub>θJA</sub> <sup>(1)</sup>	350	°C/W
	R <sub>θJC</sub> <sup>(2)</sup>	180	
Operating junction temperature range	T <sub>J</sub>	-55 to +150	°C
Storage temperature range	T <sub>STG</sub>	-55 to +150	°C

### Electrical Characteristics

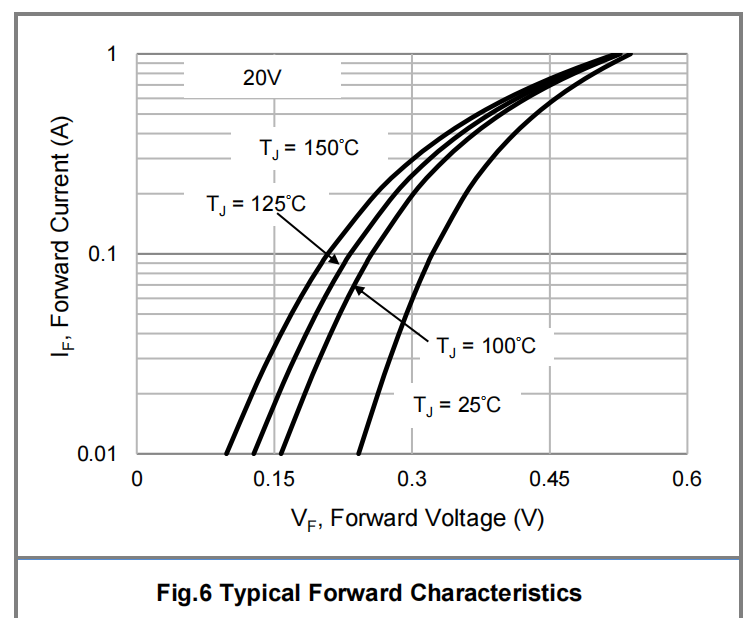
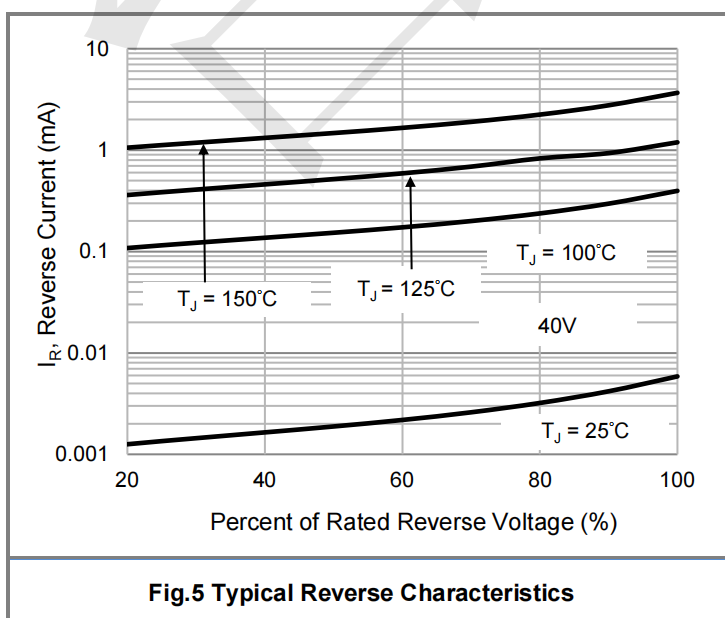
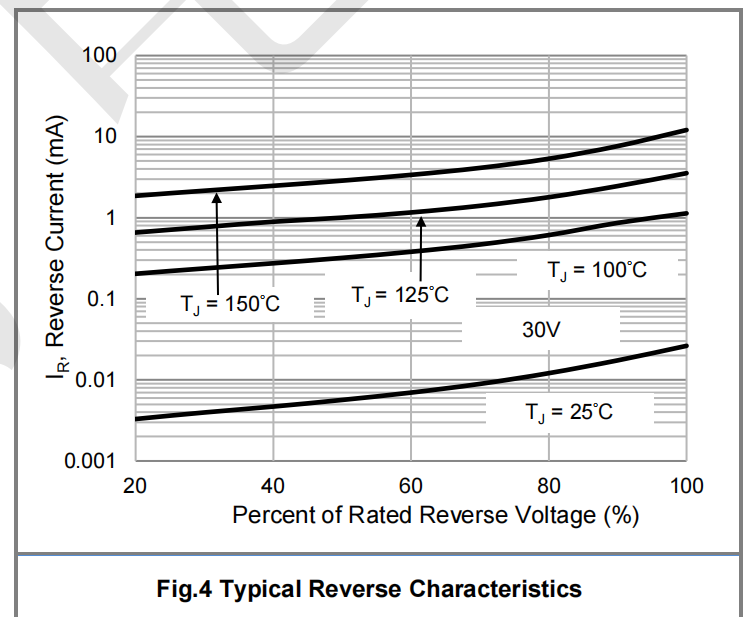
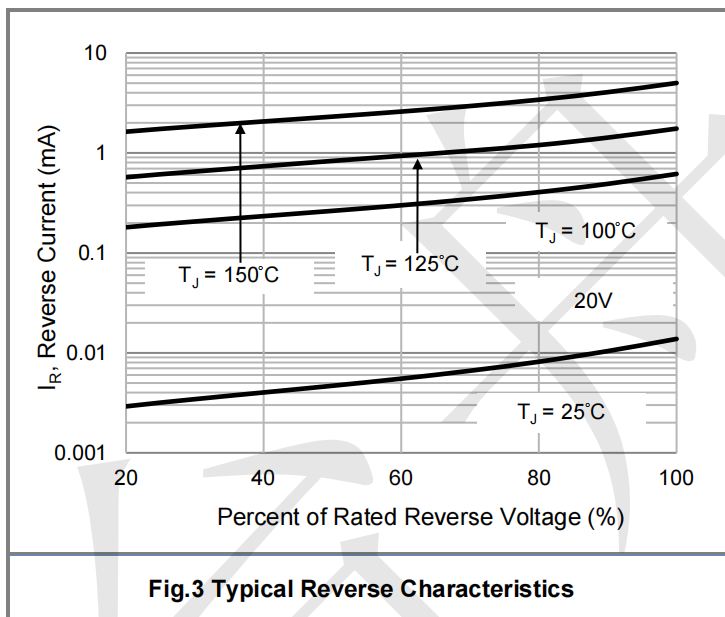
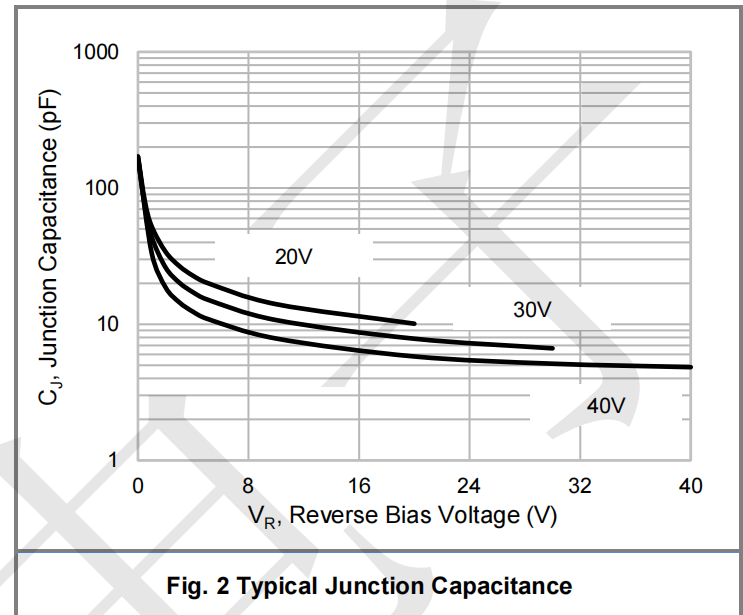
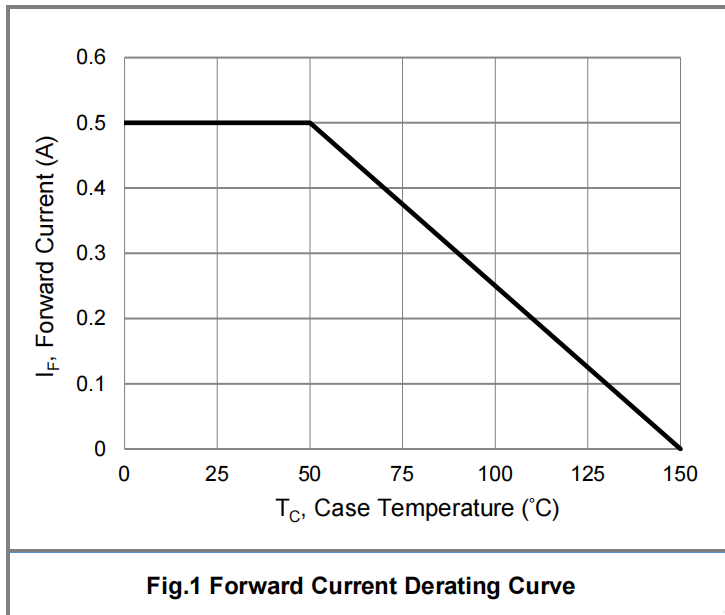
PARAMETER	SYMBOL	TEST CONDITION		TYP.	MAX.	UNIT
Forward voltage	V <sub>F</sub>	I <sub>F</sub> = 10mA	T <sub>J</sub> = 25 °C	0.23	-	V
		I <sub>F</sub> = 100mA		0.35	-	
		I <sub>F</sub> = 500mA		-	0.6	
		I <sub>F</sub> = 10mA	T <sub>J</sub> = 125 °C	0.15	-	V
I <sub>F</sub> = 100mA	0.29	-				
Reverse current	I <sub>R</sub> <sup>(3)</sup>	V <sub>R</sub> = 10V	T <sub>J</sub> = 25 °C	1.3	-	μA
		V <sub>R</sub> = 20V		1.9	-	
		V <sub>R</sub> = 30V		3.1	-	
		V <sub>R</sub> = 40V		-	50	
		V <sub>R</sub> = 20V	T <sub>J</sub> = 125 °C	0.5	-	mA
		V <sub>R</sub> = 30V		0.8	-	
V <sub>R</sub> = 40V	1.3	-				

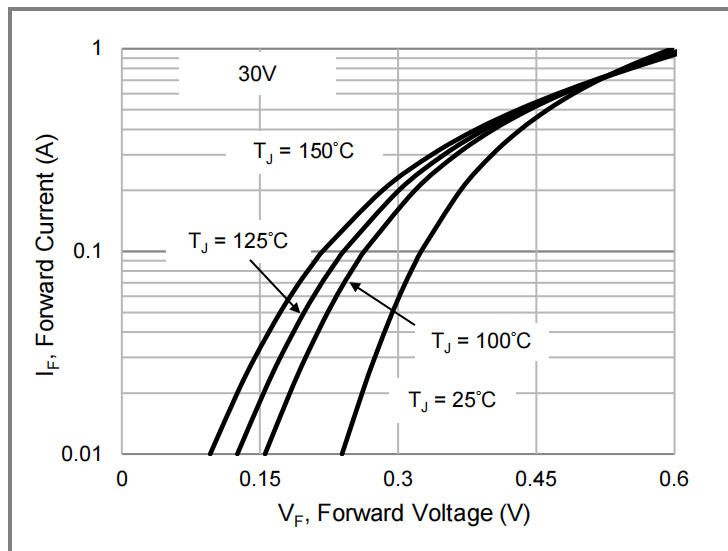
Note : 1. Mounted on a FR4 PCB, single-sided copper, mini pad.

2. Mounted on a FR4 PCB, single-sided copper, with 100cm<sup>2</sup> copper pad area.

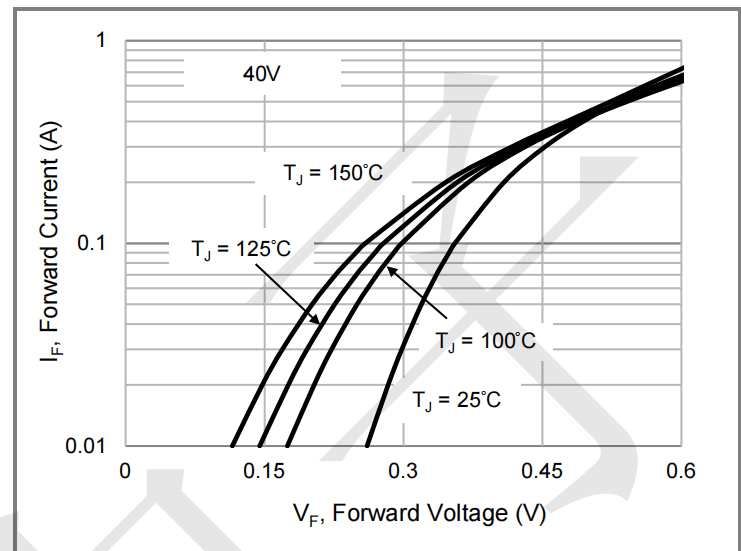
3. Short duration pulse test used to minimize self-heating effect.

**TYPICAL CHARACTERISTIC CURVES**

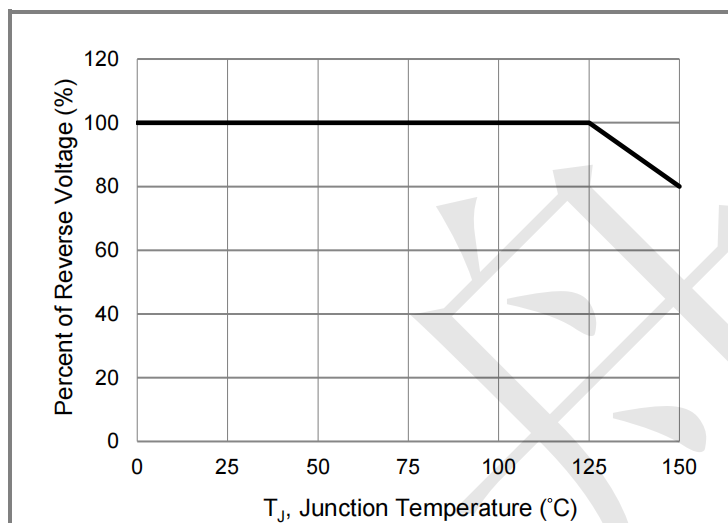




**Fig.7 Typical Forward Characteristics**



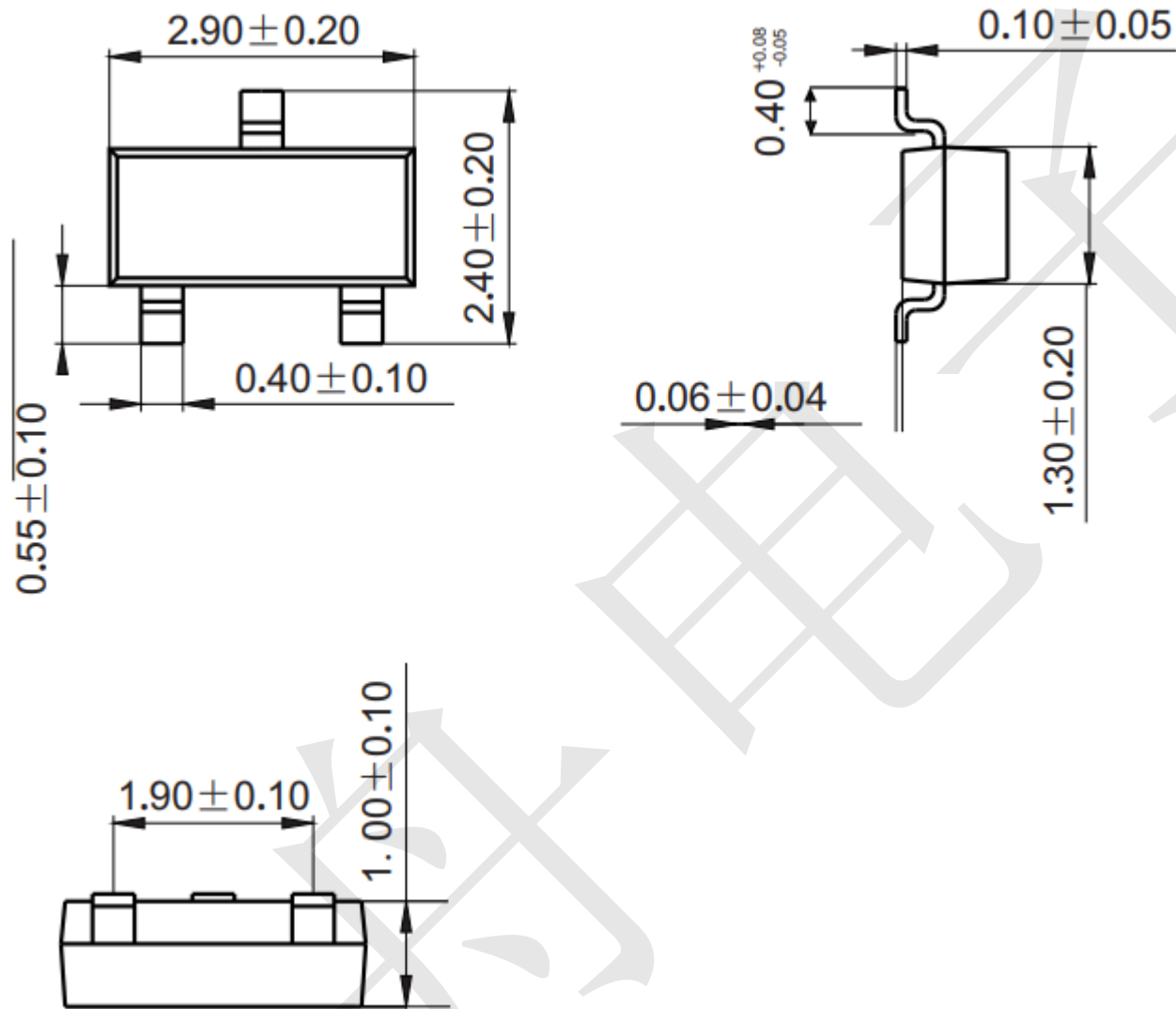
**Fig.8 Typical Forward Characteristics**



**Fig.9 Operating Temperature Derating Curve**

**Package information (Unit: mm)**

SOT-23



**Mounting Pad Layout (Unit: mm)**

