

STANDARD ORIENTATION

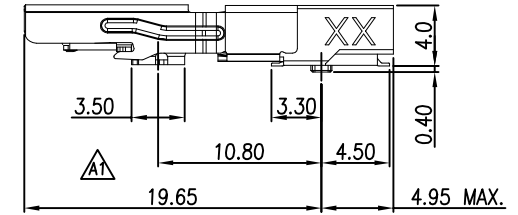

				TOLERANCE		<b>UMax</b> 东莞市友贸实业有限公司 <b>conn</b> DONGGUAN UMAX ENTERPRISE LIMITED		TITLE: DDR5 SO DIMM, 0.50Pitch, 4.0H 262P, SMT TYPE					
				LINEAR	ANGLES			PART NO. 90415-40XXSX					
A1	E2601007	Feng.PF	Apr,10,2026	.X±0.30	.X°±	APPD:	Jason	MAT'L:	DWG NO. C-90415-40				
A0	E2501001	Liu xuejun	Aug,13,2025	.XX±0.20	.XX°±	CHKD:	Schumi	FINISH:		UNITS	SCALE	SHEET	REV
REV	ECN NO.	NAME	DATE	.XXX±0.10	.XXX°±	DRWN:	Schumi	Q'TY:		MM	1 : 1	1 OF 5	A1

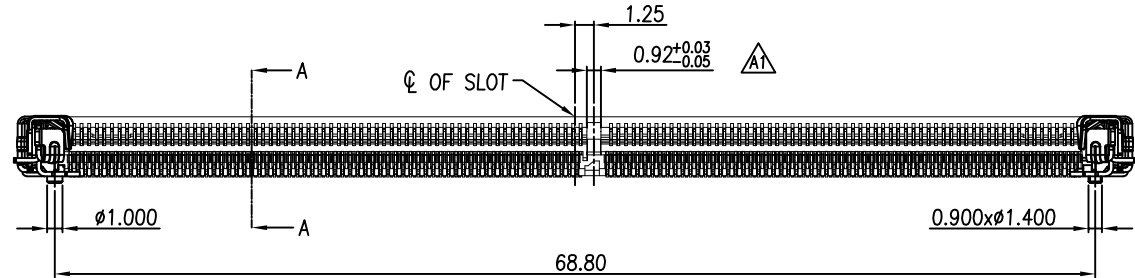
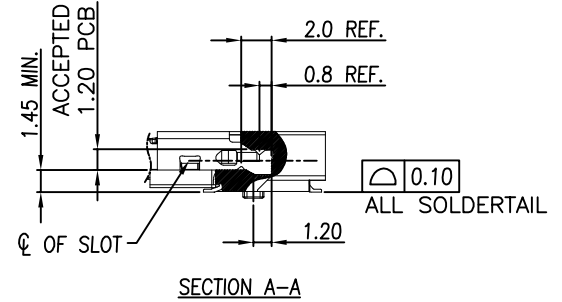
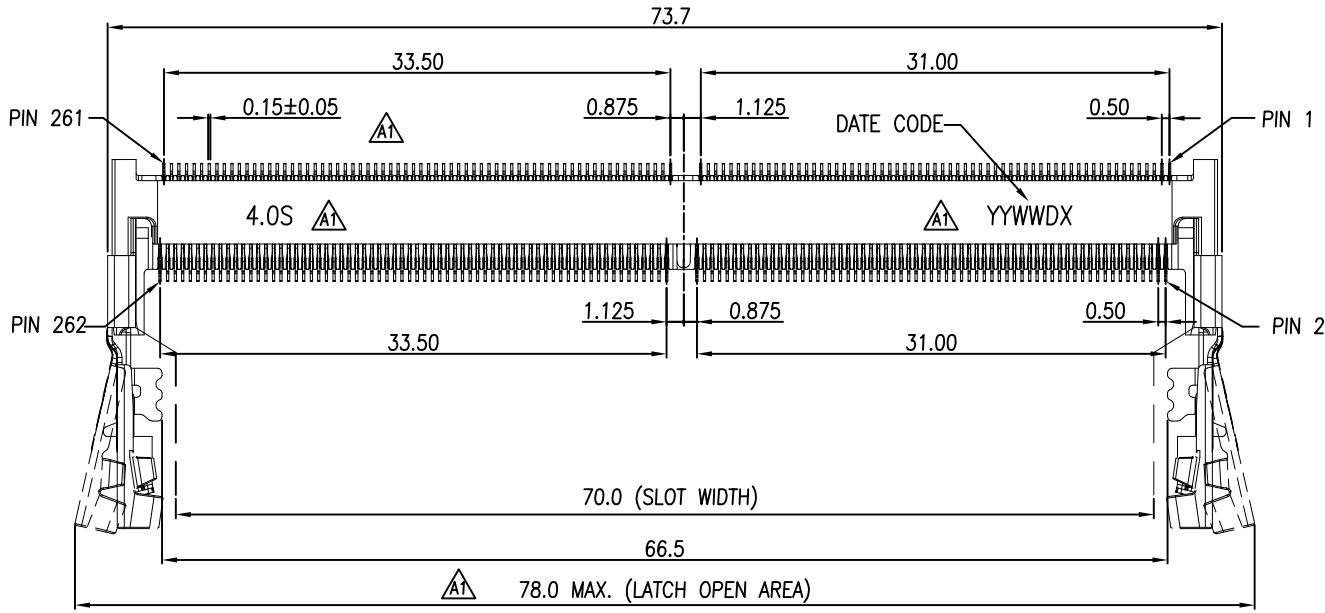

NOTES:

1. MATERIAL :

- 1.1 HOUSING: LCP WITH 30% GF, UL94 V-0, BLACK COLOR,
- 1.2 CONTACT: COPPER ALLOY.
- 1.3 LATCH: STAINLESS STEEL.
- 1.4 PEG: STAINLESS STEEL.

2. FINISH :

2.1 CONTACT

- 10u" GOLD PLATING ON THE CONTACT AREA.
- GOLD PLATING ON THE SOLDERING AREA.
- 50u" MIN NICKEL UNDERPLATING OVERALL.



2.2 PEG

- 50u" MIN NICKEL UNDERPLATING OVERALL.
- 50u" MIN MATTE TIN PLATING ENTIRE OVERALL.

PART NO.:

90415 - 40 15 X R

40: 4.0mm HEIGHT

PACKING OPTIONS  
R: TAPE & REEL

ORIENTATION  
S: STANDARD  
R: REVERSE

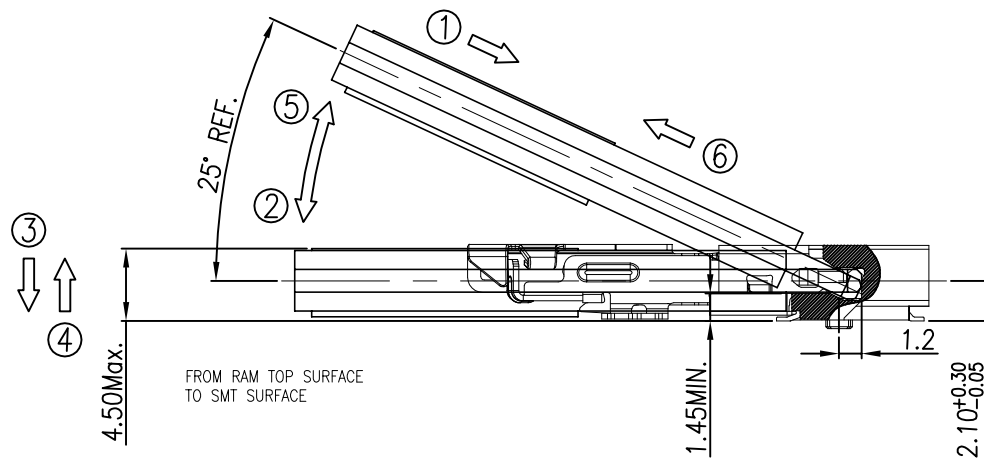

MATING: ① INSERTING — ② ROTATING — ③ FIXED  
UNMATING: ④ UNFIXED — ⑤ ROTATING — ⑥ WITHDRAWING  
MATING/UNMATING VIEW

TOLERANCE		UMax 东莞市友贸实业有限公司 conn DONGGUAN UMAX ENTERPRISE LIMITED		TITLE: DDR5 SO DIMM, 0.50Pitch, 4.0H 262P, SMT TYPE				
LINEAR	ANGLES			PART NO. 90415-40XXXX				
X.±	X°.±	APPD: Jason	MAT'L:	DWG NO. C-90415-40				
.X±	.X°.±	CHKD: Schumi	FINISH:		UNITS	SCALE	SHEET	REV
.XXX±	.XXX°.±	DRWN: Schumi	Q'TY:		MM	1 : 1	3 OF 5	A1

REV	SEE SHEET 1	NAME	DATE
ECN NO.			

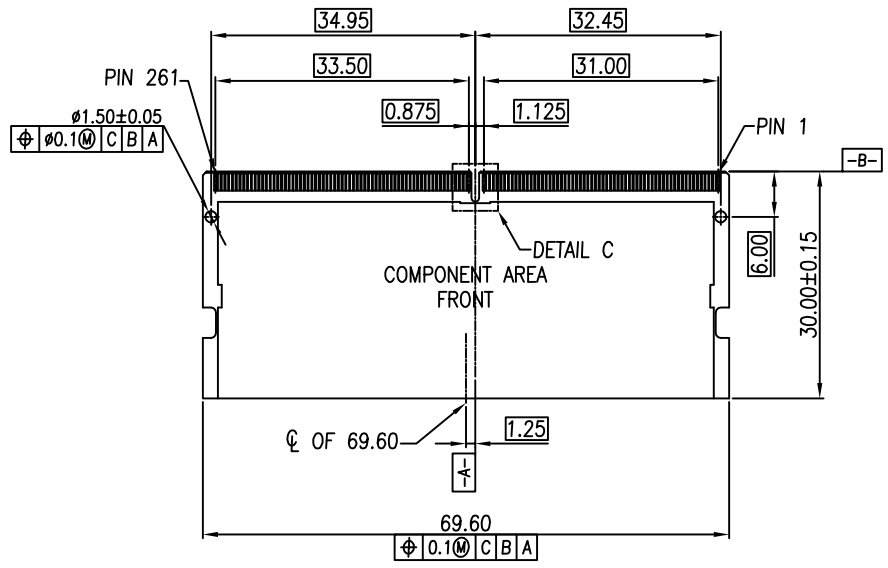

RECOMMENDED CRAD LAYOUT

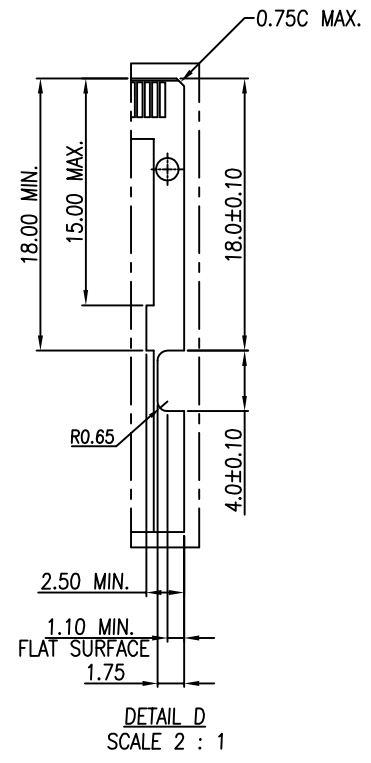
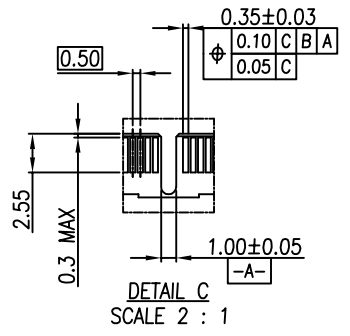
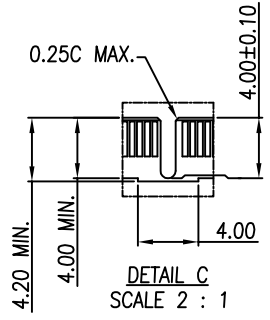
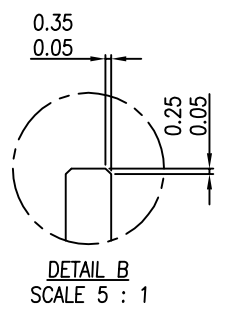
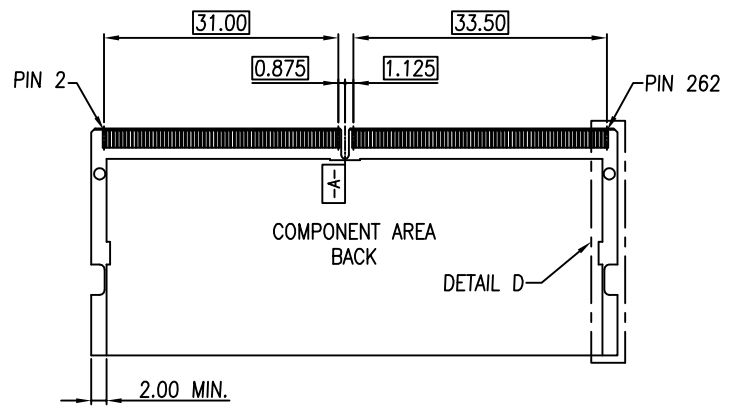
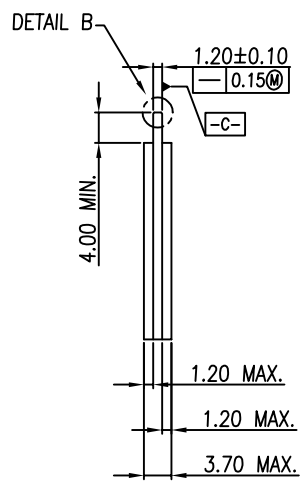

REV	ECN NO.	NAME	DATE
	SEE SHEET 1		

TOLERANCE		UMax 东莞市友贸实业有限公司 conn DONGGUAN UMAX ENTERPRISE LIMITED		TITLE: DDR5 SO DIMM, 0.50Pitch, 4.0H 262P, SMT TYPE	
LINEAR	ANGLES	APPD:	Jason	MAT'L:	
X±0.40	X'±	CHKD:	Schumi	FINISH:	
.X±0.30	.X'±	DRWN:	Schumi	Q'TY:	
.XX±0.20	.XX'±				
.XXX±0.10	.XXX'±				

PART NO.	90415-40XXXX			
DWG NO.	C-90415-40			
UNITS	SCALE	SHEET	REV	
MM	1 : 1	4 OF 5	A1	

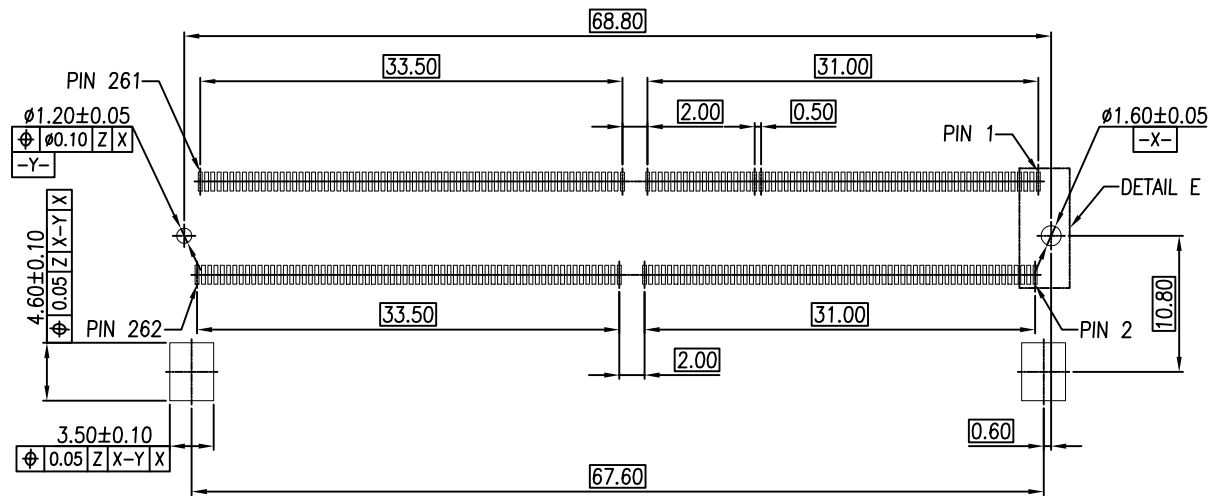

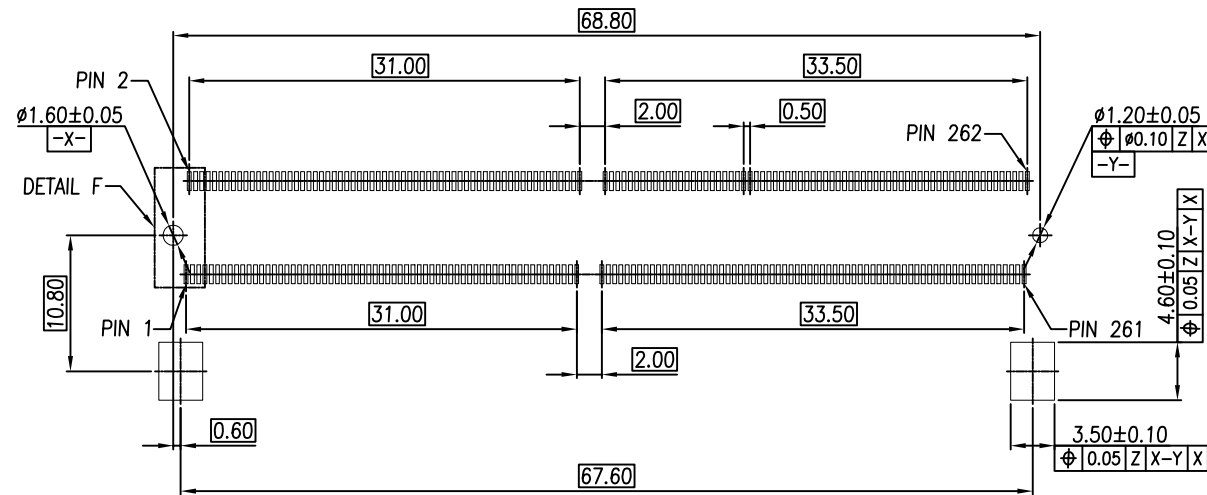
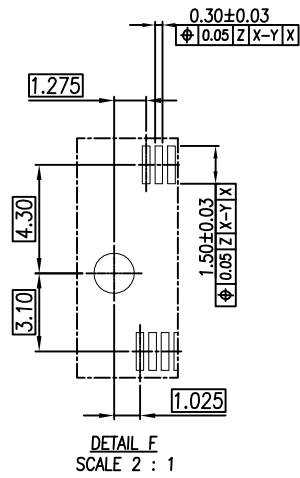
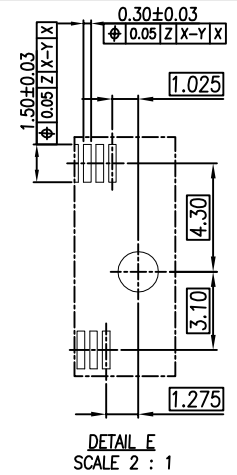

RECOMMENDED PCB LAYOUT  
STANDARD ORIENTATION  
([-Z-]: PCB SURFACE)



RECOMMENDED PCB LAYOUT  
REVERSE ORIENTATION  
([-Z-]: PCB SURFACE)

TOLERANCE		UMax 东莞市友贸实业有限公司 DONGGUAN UMAX ENTERPRISE LIMITED		TITLE: DDR5 SO DIMM, 0.50Pitch, 4.0H 262P, SMT TYPE	
LINEAR	ANGLES			PART NO. 90415-40XXXX	
X.±	X'±	APPD:	Jason	MAT'L:	
.X±	.X'±	CHKD:	Schumi	FINISH:	
.XX±	.XX'±	DRWN:	Schumi	Q'TY:	
.XXX±	.XXX'±			DWG NO. C-90415-40	

REV	SEE SHEET 1	NAME	DATE
	ECN NO.		

 	UNITS	SCALE	SHEET	REV
	MM	1 : 1	5 OF 5	A1

NOTE:

1. REEL MATERIAL : PS; COLOR: BLUE
2. CARRIER MATERIAL : PS; COLOR: BLACK
3. COVER TAPE MATERIAL : PS; COLOR: TRANSPARENT
4. COVER TAPE REEL STRENGTH : 13"
5. QUANTITY : SEE TABLE
6. Carton : 380(L) \* 380(W) \* 300(H) mm

PCS/TAPE	REELS/BOX	PCS/BOX	GROSS WEIGHT	NET WEIGHT
280	3	840	XXX	XXX

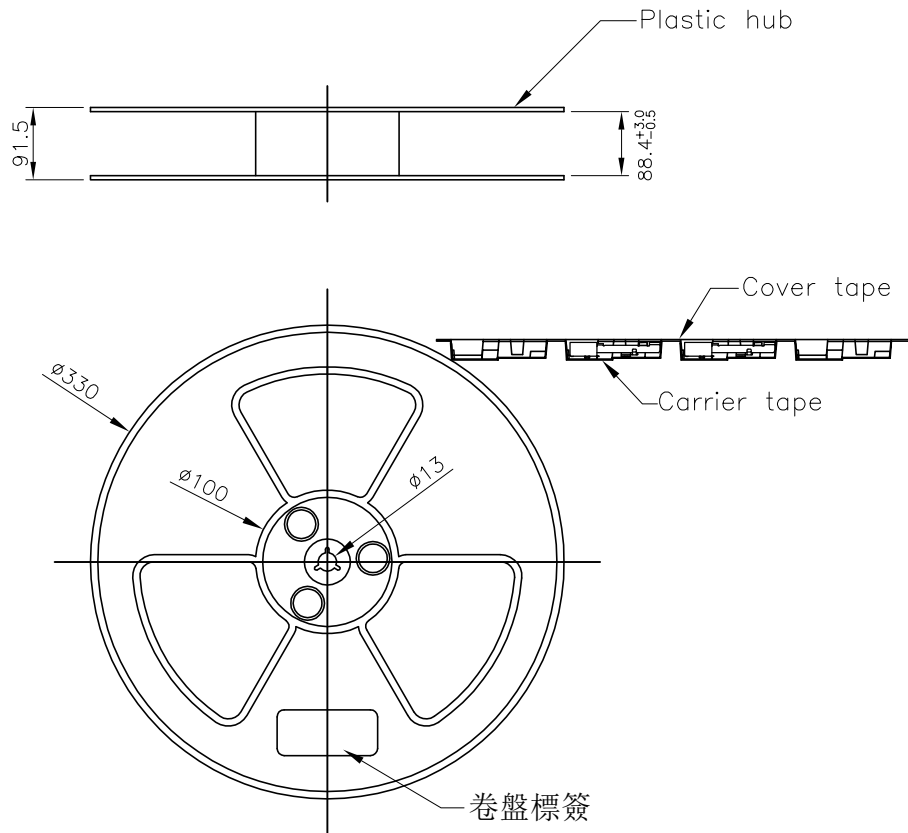

IN THE DIRECTION OF PULLING

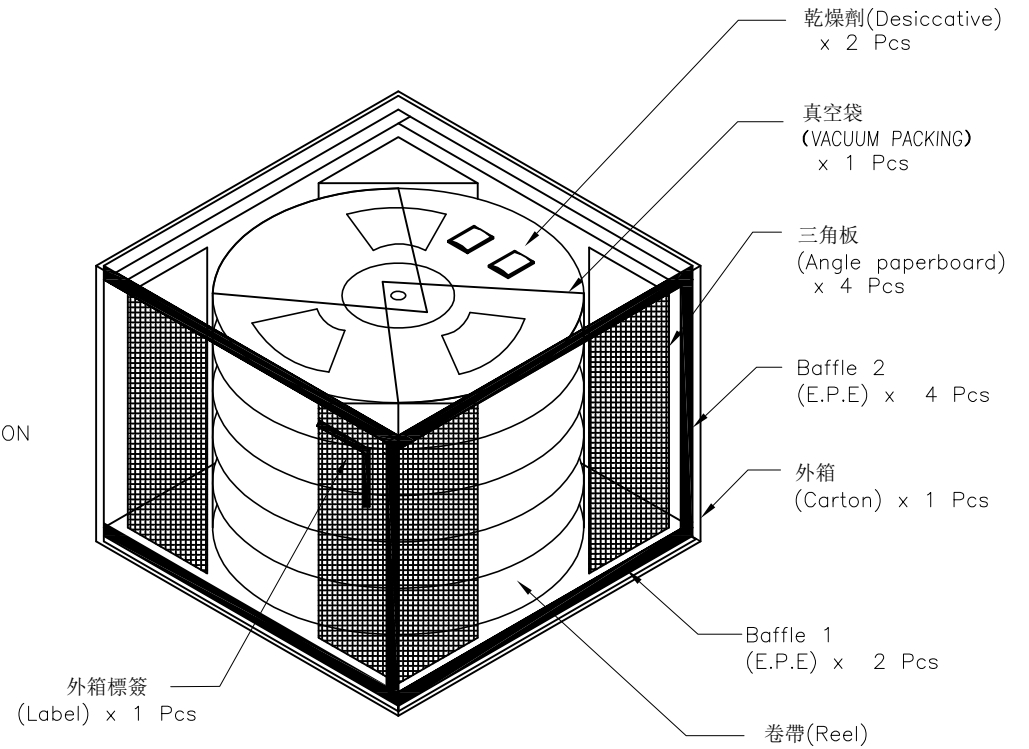

				TOLERANCE		<b>UMax conn</b> 东莞市友贸实业有限公司 DONGGUAN UMAX ENTERPRISE LIMITED		TITLE: DDR5 SODIMM 4.0H CONNECTOR PACKAGING SPECIFICATION					
				LINEAR	ANGLES			PART NO. 90415-Packing Specification					
A1	-----	Feng.PF	Apr.10.2026	.X±	.X'±	APPD:	Jason	MAT'L:	DWG NO. 9041504001				
A	E2501001	Lin xuejun	Aug.13.2024	.XX±0.20	.XX'±	CHKD:	Schumi	FINISH:		UNITS	SCALE	SHEET	REV
REV	ECN NO.	NAME	DATE	.XXX±	.XXX'±	DRWN:	Lei Songping	Q'TY:		MM	1 : 1	1 OF 3	A1

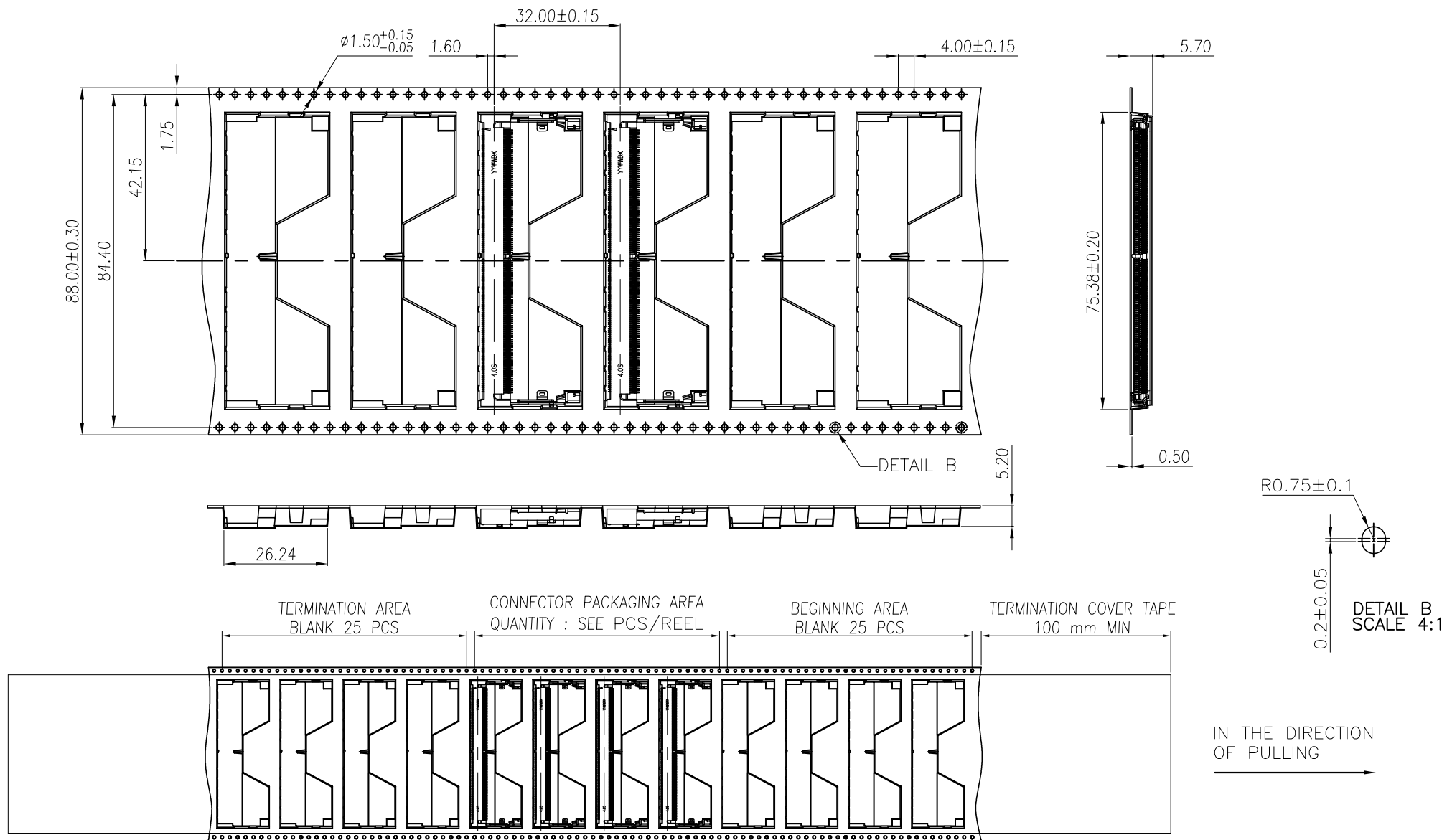

COMPOSITION OF PACKAGING

				TOLERANCE		<b>UMax</b> 东莞市友贸实业有限公司 <b>conn</b> DONGGUAN UMAX ENTERPRISE LIMITED		TITLE: DDR5 SODIMM STD 4.0H CONNECTOR PACKAGING SPECIFICATION					
				LINEAR	ANGLES			PART NO. STD-Packing Specification					
SEE SHEET 1				X.±	X'.±	APPD: Jason	MAT'L:	DWG NO. 9041504001		UNITS	SCALE	SHEET	REV
REV	ECN NO.	NAME	DATE	.XX±0.20	.XX'±	CHKD: Schumi	FINISH:	MM	1 : 1	2 OF 3	A1		
				.XXX±	.XXX'±	DRWN: Lei Songping	Q'TY:					CUSTOMER	

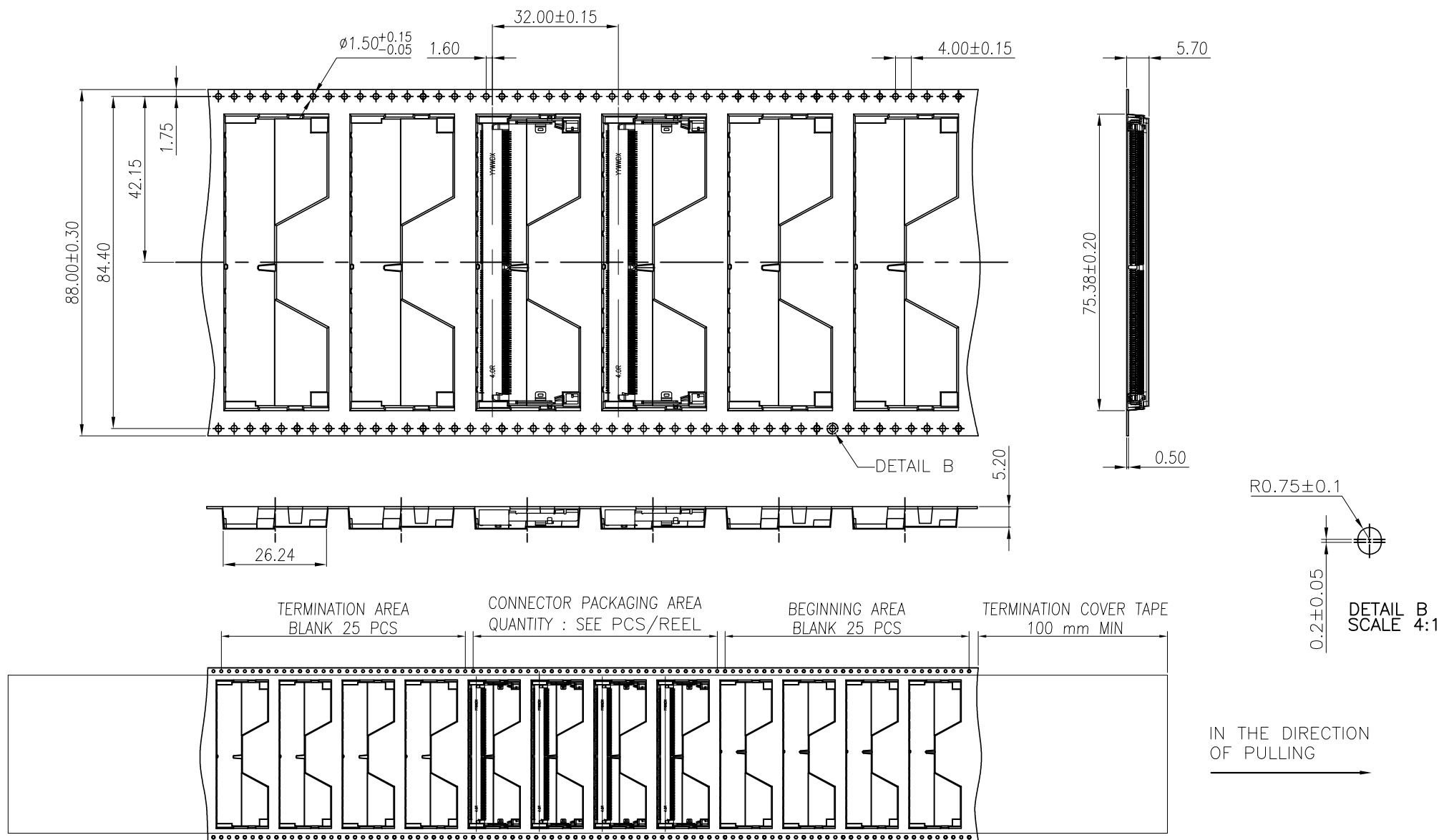

COMPOSITION OF PACKAGING

TOLERANCE	
LINEAR	ANGLES
X.±	X'.±
.X±	.X'±
.XX±0.20	.XX'±
.XXX±	.XXX'±

<b>UMax</b> 东莞市友贸实业有限公司 <b>conn</b> DONGGUAN UMAX ENTERPRISE LIMITED	
APPD: Jason	MAT'L:
CHKD: Schumi	FINISH:
DRWN: Lei Songping	Q'TY:

TITLE: DDR5 SODIMM RVS 4.0H CONNECTOR PACKAGING SPECIFICATION			
PART NO. RVS-Packing Specification			
DWG NO. 9041504001			
UNITS	SCALE	SHEET	REV
MM	1 : 1	3 OF 3	A1

SEE SHEET 1			
REV	ECN NO.	NAME	DATE