

1. DESCRIPTION

These monolithic BCD-to-decimal decoders consist of eight inverters and ten four-input NAND gates. The inverters are connected in pairs to make BCD input data available for decoding by the NAND gates. Full decoding of valid input logic ensures that all outputs remain off for all invalid input conditions.

The 'LS42 feature inputs and outputs that are compatible for use with most TTL and other saturated low-level logic circuits. DC noise margins are typically one volt.

2. FEATURES

- All Outputs Are High for invalid Input Conditions
- Also for Application as
 - 4-Line-to-16-Line Decoders
 - 3-Line-to-8-Line Decoders
- Diode-Clamped Inputs

3. PIN CONFIGURATIONS

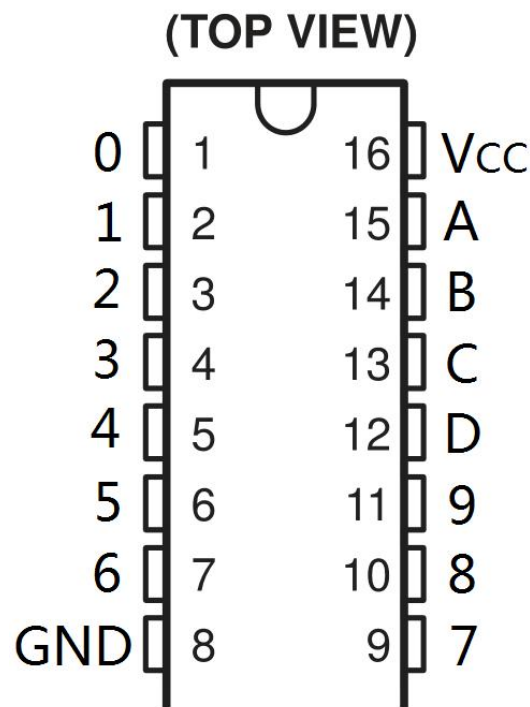

4. LOGIC SYMBOL

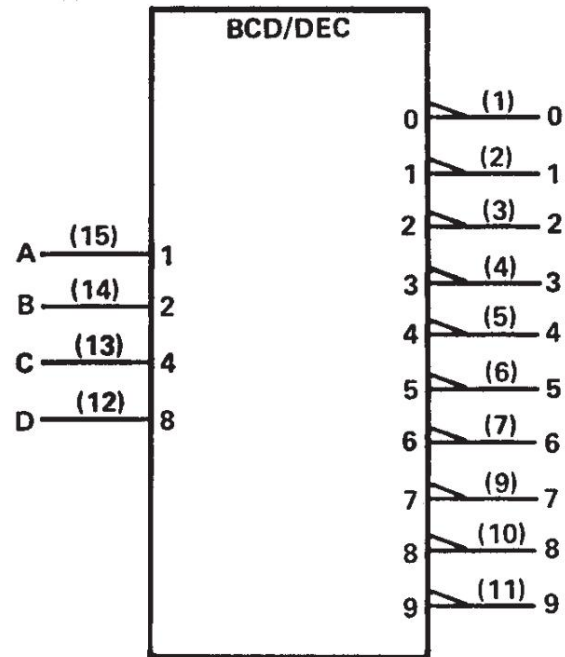

| NO. | BCD INPUT | | | | DECIMAL OUTPUT | | | | | | | | | |
|---------|-----------|---|---|---|----------------|---|---|---|---|---|---|---|---|---|
| | D | C | B | A | 0 | 1 | 2 | 3 | 4 | 5 | 6 | 7 | 8 | 9 |
| 0 | L | L | L | L | L | H | H | H | H | H | H | H | H | H |
| 1 | L | L | L | H | H | L | H | H | H | H | H | H | H | H |
| 2 | L | L | H | L | H | H | L | H | H | H | H | H | H | H |
| 3 | L | L | H | H | H | H | H | L | H | H | H | H | H | H |
| 4 | L | H | L | L | H | H | H | H | L | H | H | H | H | H |
| 5 | L | H | L | H | H | H | H | H | H | L | H | H | H | H |
| 6 | L | H | H | L | H | H | H | H | H | H | L | H | H | H |
| 7 | L | H | H | H | H | H | H | H | H | H | H | L | H | H |
| 8 | H | L | L | L | H | H | H | H | H | H | H | H | L | H |
| 9 | H | L | L | H | H | H | H | H | H | H | H | H | H | L |
| INVALID | H | L | H | L | H | H | H | H | H | H | H | H | H | H |
| | H | L | H | H | H | H | H | H | H | H | H | H | H | H |
| | H | H | L | L | H | H | H | H | H | H | H | H | H | H |
| | H | H | L | H | H | H | H | H | H | H | H | H | H | H |
| | H | H | H | L | H | H | H | H | H | H | H | H | H | H |
| | H | H | H | H | H | H | H | H | H | H | H | H | H | H |

5. LOGIC DIAGRAMS

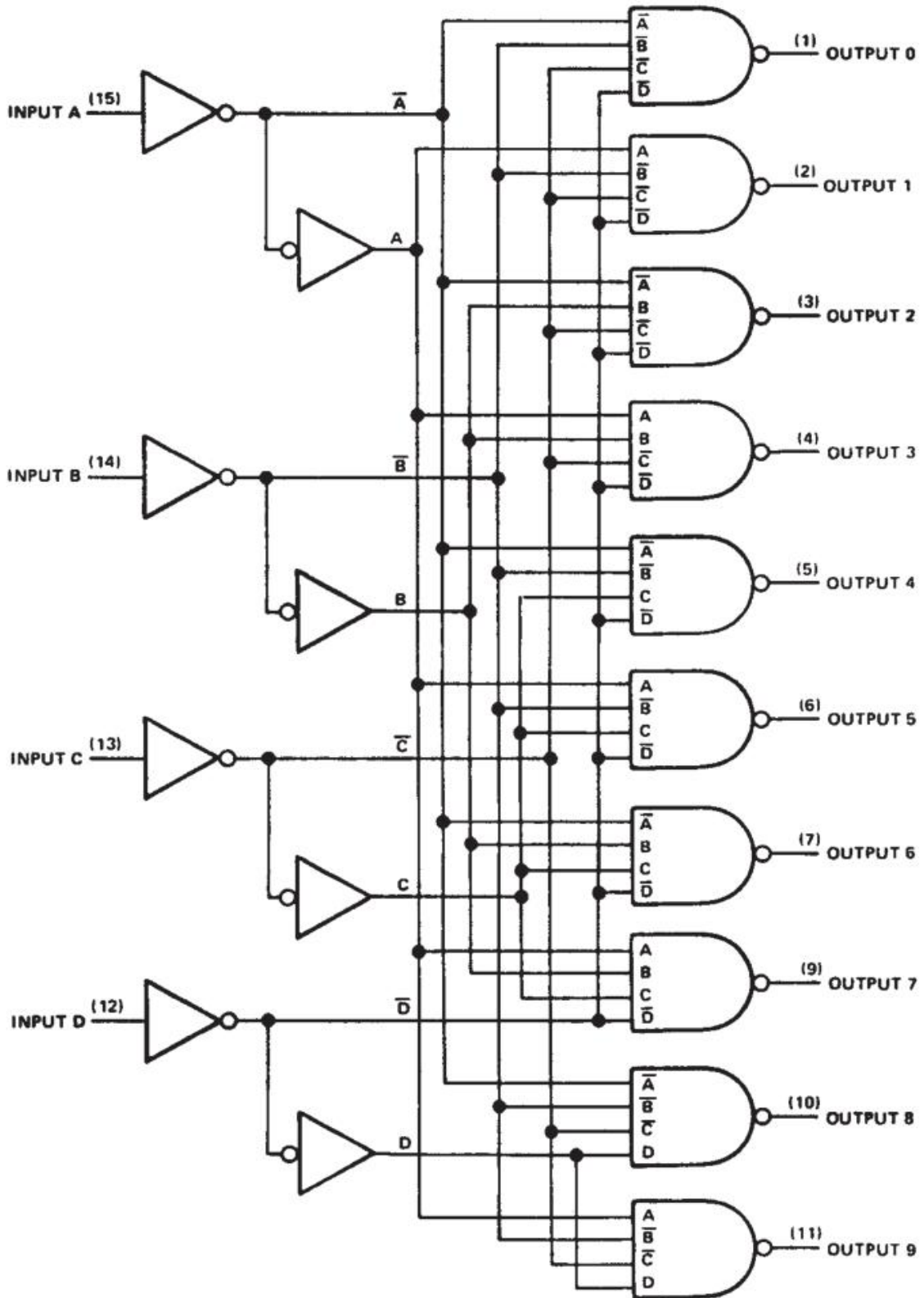

6. SCHEMATICS OF INPUTS AND OUTPUTS

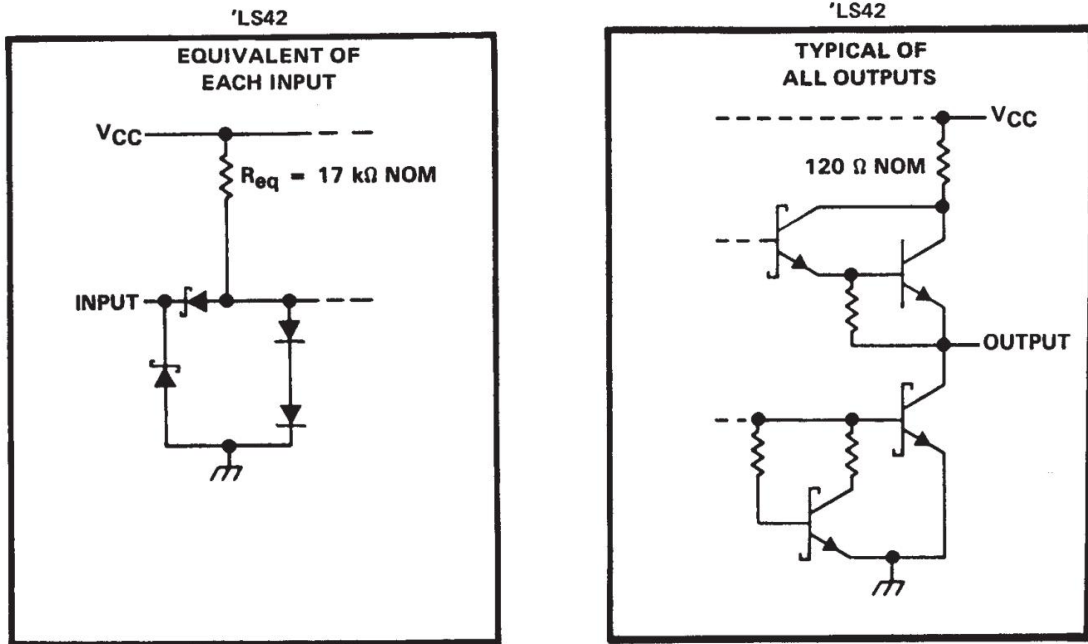

7. ABSOLUTE MAXIMUM RATINGS OVER OPERATING FREE-AIR TEMPERATURE RANGE (UNLESS OTHERWISE NOTES)

| | |
|--|----------------|
| Supply voltage, V_{CC} | 7V |
| Input voltage, V_I : 74LS42..... | 7V |
| Operating free-air temperature range: DIP package..... | 0°C to 70°C |
| Storage temperature range, T_{stg} | -65°C to 150°C |

† Stresses beyond those listed under “absolute maximum ratings” may cause permanent damage to the device. These are stress ratings only, and functional operation of the device at these or any other conditions beyond those indicated under “recommended operating conditions” is not implied. Exposure to absolute-maximum-rated conditions for extended periods may affect device reliability.

8. RECOMMENDED OPERATING CONDITIONS

| | | 74LS42 | | | UNIT |
|-----------------|--------------------------------|--------|-----|------|------|
| | | MIN | NOM | MAX | |
| V _{CC} | Supply voltage | 4.75 | 5 | 5.25 | V |
| I _{OH} | High-level output current | -400 | | | μA |
| I _{OL} | Low-level output current | 8 | | | mA |
| T _A | Operating free-air temperature | 0 | 70 | | °C |

9. ELECTRICAL CHARACTERISTICS OVER RECOMMENDED OPERATING FREE-AIR RANGE (UNLESS OTHERWISE NOTED)

| PARAMETER | | TEST CONDITIONS [†] | 74LS42 | | | UNIT |
|-----------------|---|--|------------------------|------------------|-----|------|
| | | | MIN | TYP [‡] | MAX | |
| V _{IH} | High-level input voltage | | 2 | | | V |
| V _{IL} | Low-level input voltage | | 0.8 | | | V |
| V _{IK} | Input clamp voltage | V _{CC} = MIN, I _I = -18 mA | -1.5 | | | V |
| V _{OH} | High-level output voltage | V _{CC} = MIN, V _{IL} = 0.8 V, V _{IH} = 2 V, I _{OH} = -400 μA | 2.7 | 3.5 | | V |
| V _{OL} | Low-level output voltage | V _{CC} = MIN, V _{IH} = 2 V, V _{IL} = V _{IL} MAX | I _{OL} = 4 mA | 0.25 | 0.4 | V |
| | | | I _{OL} = 8 mA | 0.35 | 0.5 | |
| I _I | Input current at maximum input voltage | V _{CC} = MAX, V _I = 7 V | 0.1 | | | mA |
| I _{IH} | High-level input current | V _{CC} = MAX, V _I = 2.7 V | 20 | | | μA |
| I _{IL} | Low-level input current | V _{CC} = MAX, V _I = 0.4 V | -0.4 | | | mA |
| I _{OS} | Short-circuit output current [§] | V _{CC} = MAX | -20 | -100 | | mA |
| I _{CC} | Supply current | V _{CC} = MAX, Output open, All inputs at 4.5V | 10.4 | 13 | | mA |

[†] For conditions shown as MIN or MAX, use the appropriate value specified under recommended operating conditions.

[‡] All typical values are at V_{CC} = 5 V, T_A = 25°C.

[§] Not more than one output should be shorted at a time.

10. SWITCHING CHARACTERISTICS, V_{CC} = 5 V, T_A = 25°C

switching characteristics, V_{CC} = 5 V, T_A = 25°C

| PARAMETER† | TEST CONDITIONS | MIN | TYP | MAX | UNIT |
|------------------|--|-----|-----|-----|------|
| t _{PLH} | C _L = 15 pF, R _L = 2 kΩ | | 15 | 25 | ns |
| t _{PHL} | | | 20 | 30 | ns |
| t _{PLH} | | | 15 | 25 | ns |
| t _{PHL} | | | 20 | 30 | ns |

† t_{PLH} = propagation delay time, low-to-high-level output

t_{PHL} = propagation delay time, high-to-low-level output

11. ORDERING INFORMATION

Ordering Information

| Part Number | Device Marking | Package Type | Body size (mm) | Temperature (°C) | MSL | Transport Media | Package Quantity |
|-------------|----------------|--------------|----------------|------------------|------|-----------------|------------------|
| XD74LS42 | XD74LS42 | DIP16 | 19.05 * 6.35 | -0 to 70 | MSL3 | Tube 25 | 1000 |

12. DIMENSIONAL DRAWINGS

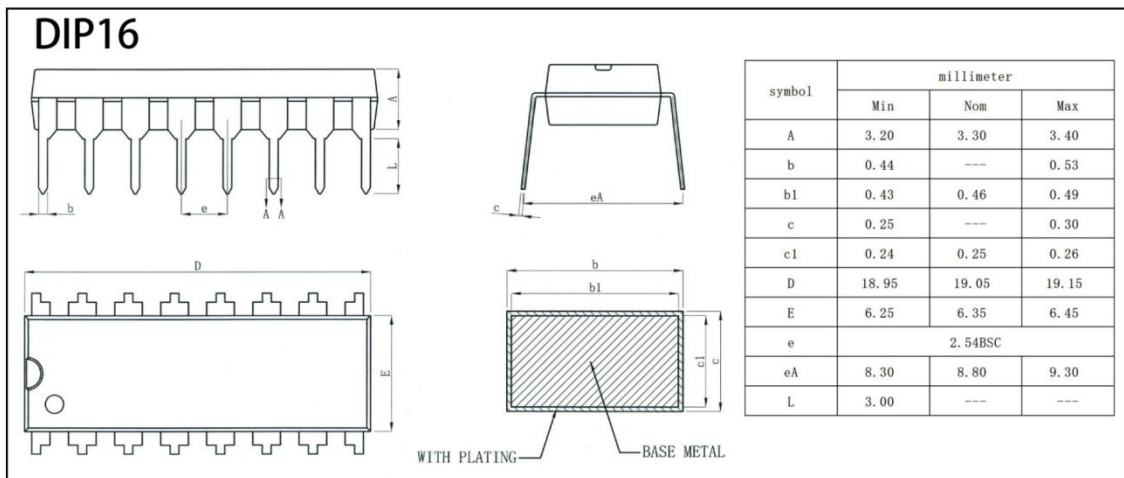

[if you need help contact us. Xinluda reserves the right to change the above information without prior notice]