

## N-Channel Enhancement Mode MOSFET

### Feature

- 25V/0.71A,  $R_{DS(ON)} = 400\text{m}\Omega(\text{MAX})$  @  $V_{GS} = 4.5\text{V}$ .  
 $R_{DS(ON)} = 450\text{m}\Omega(\text{MAX})$  @  $V_{GS} = 2.7\text{V}$ .
- Super High dense cell design for extremely low  $R_{DS(ON)}$ .
- ESD Protection HBM >1KV
- SOT-23 for Surface Mount Package.

$BV_{DSS}$	$R_{DS(ON)}$	$I_D$
25V	300m $\Omega$	0.71A

### Applications

- Power Management
- Portable Equipment and Battery Powered Systems.

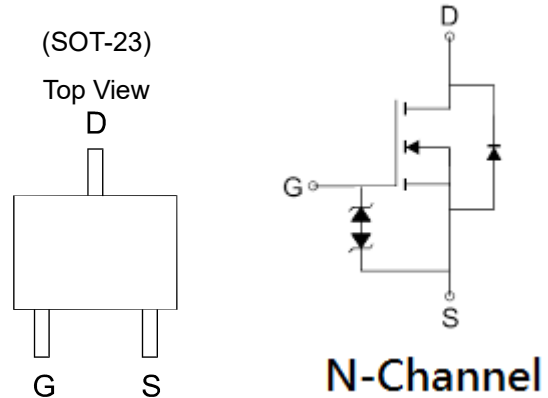

### Absolute Maximum Ratings $T_A=25^\circ\text{C}$ Unless Otherwise noted

Parameter	Symbol	Limit	Units
Drain-Source Voltage	$V_{DS}$	25	V
Gate-Source Voltage	$V_{GS}$	$\pm 8$	V
Drain Current-Continuous	$I_D$	0.71	A

### Electrical Characteristics $T_A=25^\circ\text{C}$ Unless Otherwise noted

Parameter	Symbol	Test Conditions	Min	Typ.	Max	Units
<b>Off Characteristics</b>						
Drain to Source Breakdown Voltage	$BV_{DSS}$	$V_{GS}=0\text{V}, I_D=250\mu\text{A}$	25	-	-	V
Zero-Gate Voltage Drain Current	$I_{DSS}$	$V_{DS}=25\text{V}, V_{GS}=0\text{V}$	-	-	1	$\mu\text{A}$
Gate Body Leakage Current, Forward	$I_{GSSF}$	$V_{GS}=8\text{V}, V_{DS}=0\text{V}$	-	-	10	nA
Gate Body Leakage Current, Reverse	$I_{GSSR}$	$V_{GS}=-8\text{V}, V_{DS}=0\text{V}$	-	-	-10	nA
<b>On Characteristics</b>						
Gate Threshold Voltage	$V_{GS(th)}$	$V_{GS}=V_{DS}, I_D=250\mu\text{A}$	0.5	-	1.0	V
Static Drain-source On-Resistance	$R_{DS(ON)}$	$V_{GS}=4.5\text{V}, I_D=2\text{A}$	-	300	400	m $\Omega$
		$V_{GS}=2.5\text{V}, I_D=1.5\text{A}$	-	340	450	m $\Omega$
<b>Drain-Source Diode Characteristics and Maximum Ratings</b>						
Drain-Source Diode Forward Voltage	$V_{SD}$	$V_{GS}=0\text{V}, I_S=0.94\text{A}$		0.8	1.2	V

## Typical Characteristics

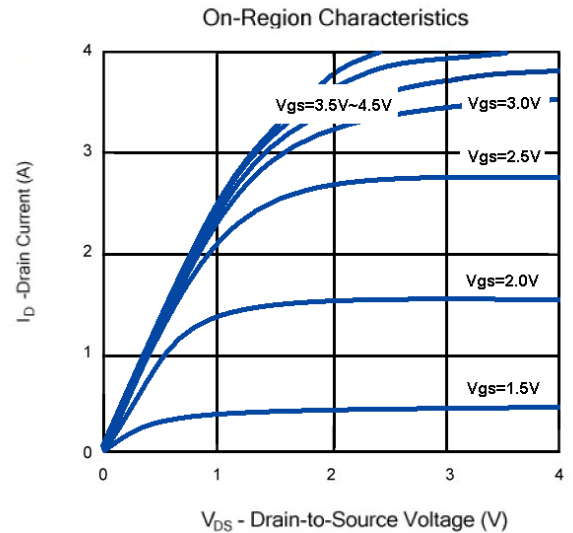
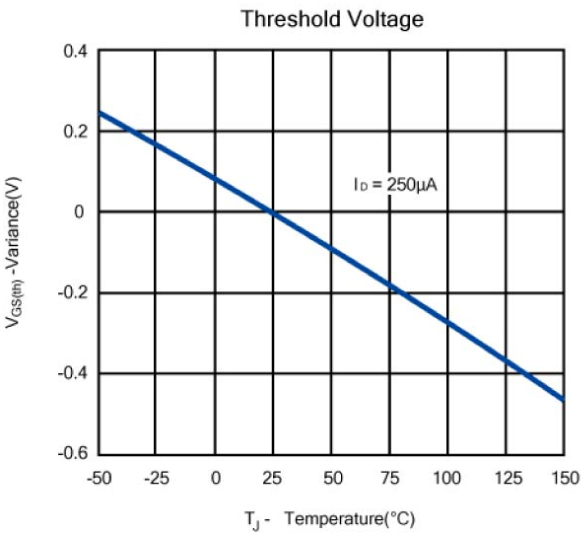
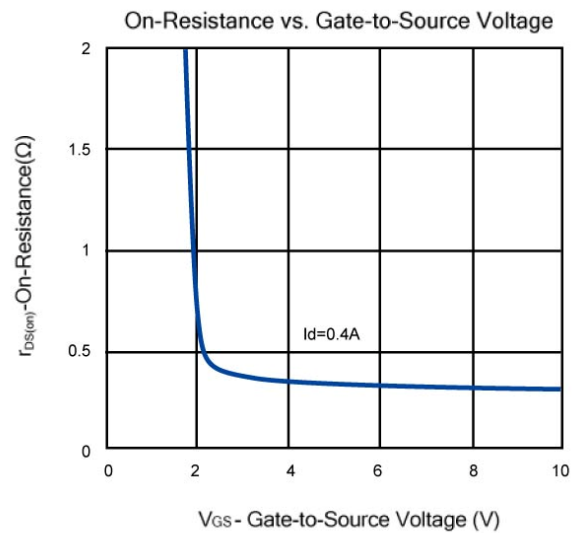
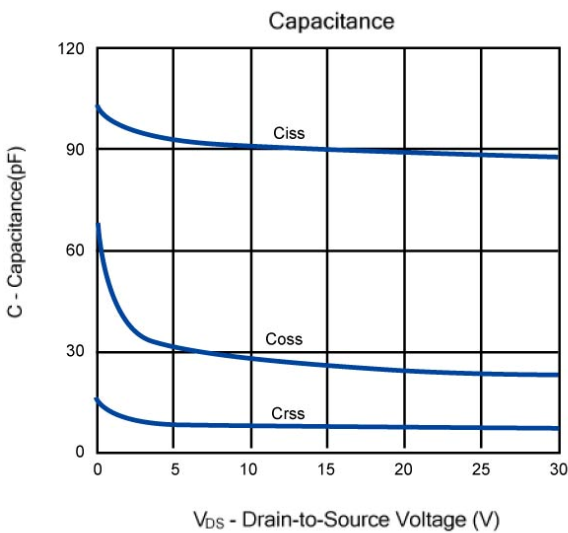
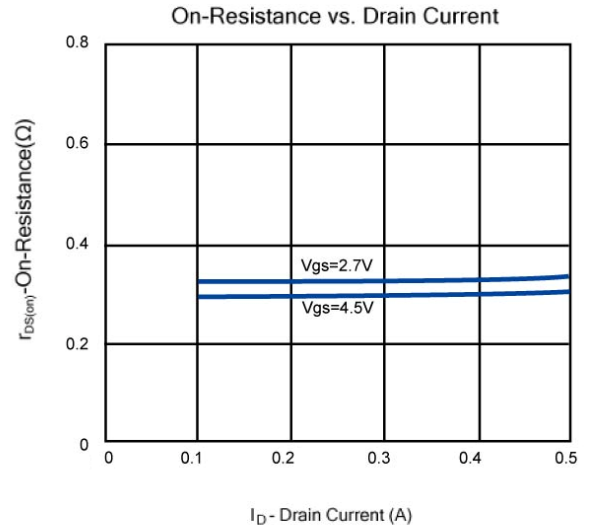
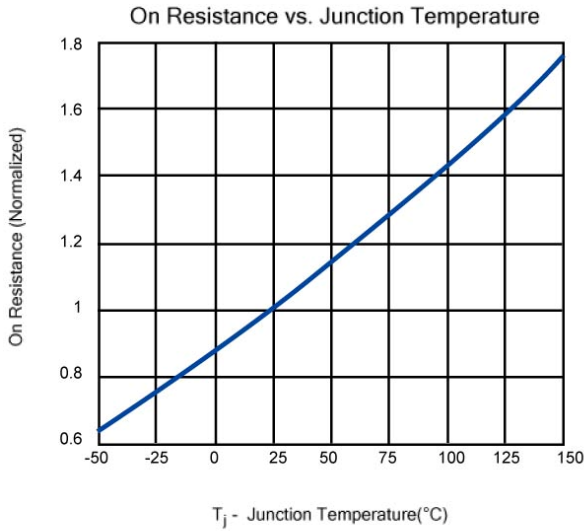

## Typical Characteristics

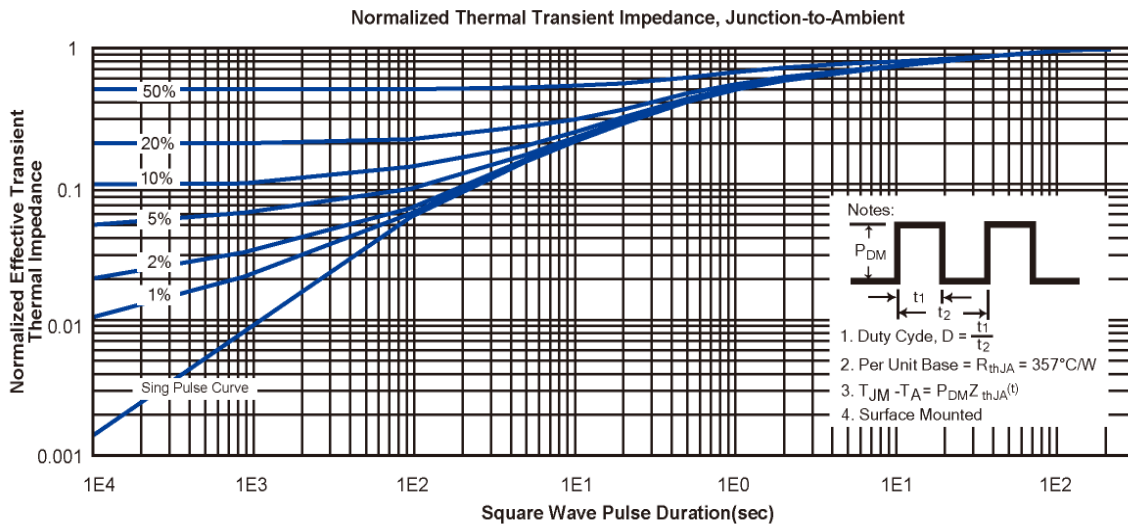
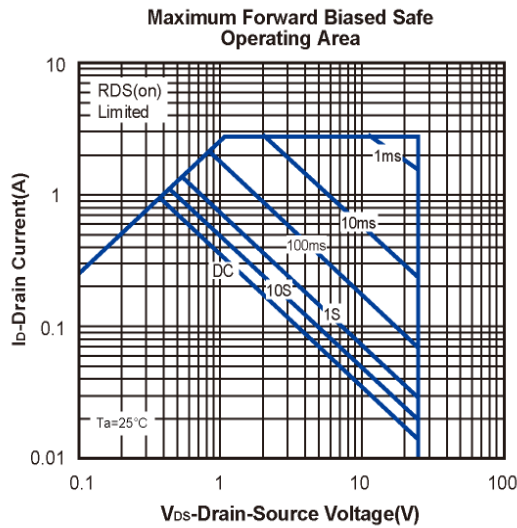
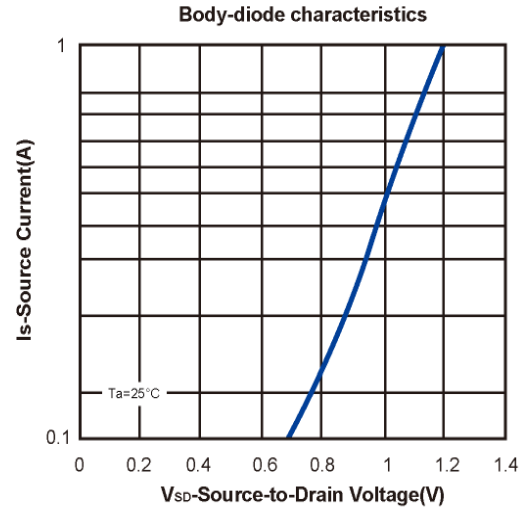
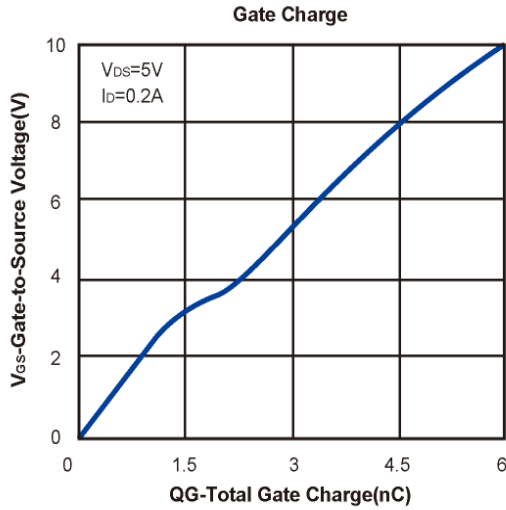

Package Outline Dimensions (UNIT: mm)

SOT-23

