

修订	标记	修改摘要	签名	日期
REV	MARK	REVISION DESCRIPTION	SIGNATURE	DATE
AO		NEW DWG		2016-03-12

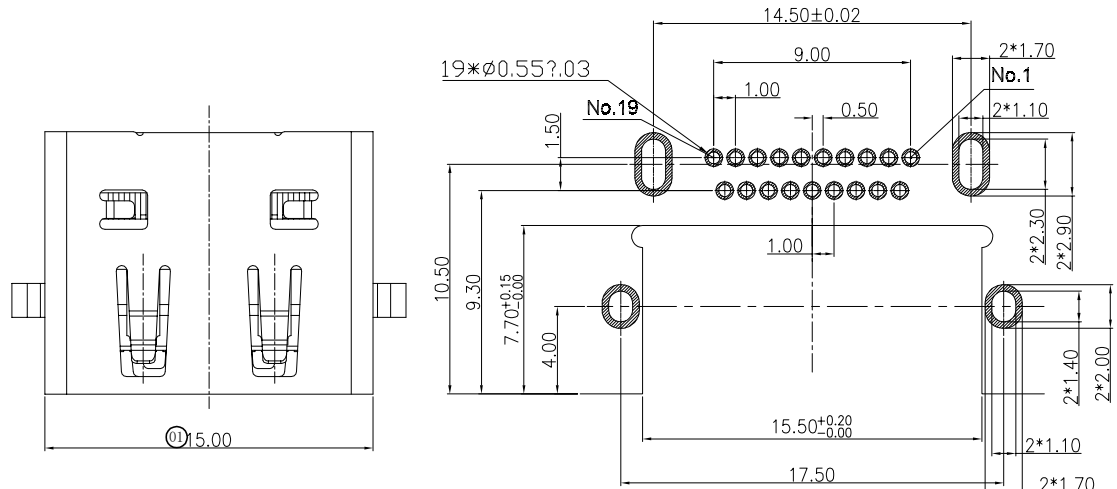

Recommended pcb layout (top view)
(thickness=1.2±0.10mm) (tolerance ±0.05)

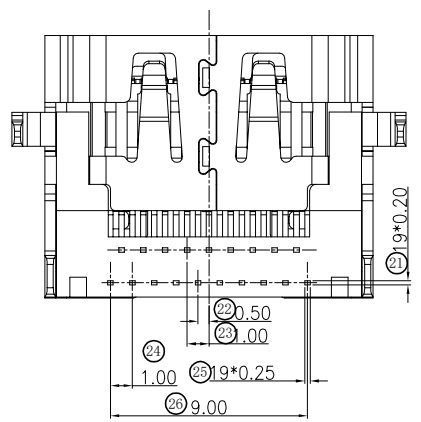
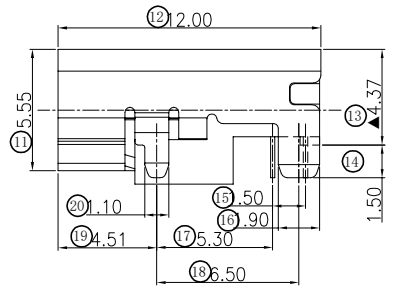
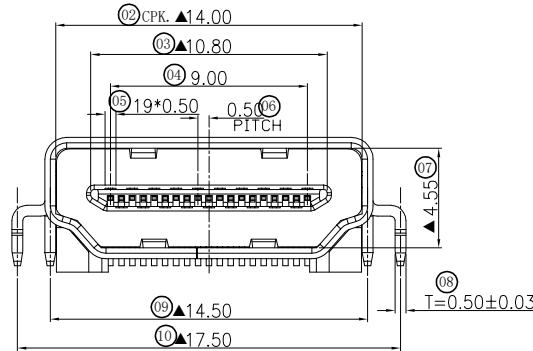

Note:

- Mechanical characteristics
insertion force: 44.1N max
withdrawal force: 9.8N min, 39.2N max
mating cycle: 10000 cycles
- Electrical characteristics
rating current: 0.5A
rating voltage: 40V
contact resistance: 10 milliohms max
(excluding conductor resistance)
insulation resistance:
a, unmated: 100M Ohms min at 500 VDC
b, mated: 10M Ohms min at 150 VDC
dielectric withstanding voltage: 300V AC/1minute
operating temperature: -20°C~+85°C
storage temperature: -20°C~+65°C
- material:
HOUSING: THERMOPLASTICS HIGH TEMP LCP+GLASS
FIBER BLACK COLOR, UL94V-0
CONTACT: Copper Alloy, T=0.20MM
SHELL: Copper Alloy (SPCC), T=0.5MM

由Autodesk教育版产品制作

由Autodesk教育版产品制作

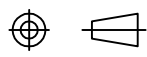
		深圳市华德共创科技有限公司 Shenzhen Huade co-create Technology Co., LTD 电话: 0755-27111216 传真: 0755-29940187			
-TOLERANCES- UNLESS OTHERWISE SPECIFIED 公差参数表				TITLE: 产品名称: HDMI AF正向沉板铁壳镀镍黑胶4.37	
X.X	±0.30	X.X*	±3°	APPD: 核准:	
X.XX	±0.20	X.XX*	±2°	CHECK: 校对: 王建业	
X.XXX	±0.10	X.XXX*	±1°	DRAW: 绘图: 黄艳兰	
				PART NO: 产品编号: HDMI-GD-112PWB	DATE 2016-03-12
				SCALE 1:1	UNIT mm
				CODE NUMBER A001	

由Autodesk教育版产品制作