

SuperESD - ESDA7P60-1U1M-ES

1. Description

The ESDA7P60-1U1M-ES ESD protector is designed to replace multilayer varistors (MLVs) in portable applications such as cell phones, notebook computers, and PDA's. They feature large cross-sectional area junctions for conducting high transient currents, offer desirable electrical characteristics for board level protection, such as fast response time, lower operating voltage, lower clamping voltage and no device degradation when compared to MLVs. The ESDA7P60-1U1M-ES protects sensitive semiconductor components from damage or upset due to electrostatic discharge (ESD) and other voltage induced transient events.

2. Features

- IEC 61000-4-2 Level 4 ESD Protection
 - ±30kV Contact Discharge
 - ±30kV Air Discharge
- 1500W Peak pulse Power (8/20us)
- RoHS compliance
- Unidirectional configuration
- Low clamping voltage
- Working voltage: 4V/5V/12V/15V/18V/26V

3. Applications

- Cell phone handsets and accessories
- Personal digital assistants
- Cordless phones
- Notebooks, desktops, and servers
- Portable instrumentation
- Digital cameras

4. Ordering Information

Part Number	Package	Material	Packing	Quantity per reel	Flammability Rating	Reel Size
ESDA7P60-1U1M-ES	DFN1610-2L	HA	Tape & Reel	3,000 PCS	UL 94V-0	7 inches

Table-1 Ordering information

5. Pin Configuration and Functions

Pin	Name	Description	Outline	Circuit Diagram
1	IO	Connect to IO		
2	GND	Connect to GND		

Table-2 Pin configuration

6. Specification

6.1. Absolute Maximum rating

Over operating free-air temperature range (unless otherwise noted)

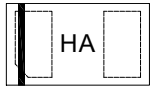
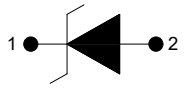
Parameters	Symbol	Min.	Max.	Unit
Peak pulse power (tp=8/20us)@25°C	P _{pk}	-	1500	W
Peak pulse current (tp=8/20us)@25°C	I _{PP}		Refer to Table-5	A
ESD (IEC61000-4-2 air discharge) @25°C	V _{ESD}	-	±30	kV
ESD (IEC61000-4-2 contact discharge) @25°C	V _{ESD}	-	±30	kV
Junction temperature	T _J	-	150	°C
Operating temperature	T _{OP}	-40	125	°C
Storage temperature	T _{STG}	-55	150	°C
Lead temperature	T _L	-	260	°C

Table-3 Absolute Maximum rating

6.2. Electrical Characteristics

Symbol	Description
V_{RWM}	Rated reverse stand-off voltage
V_{BR}	Minimum breakdown voltage @ $I_T = 1\text{mA}$
V_{CL}	Clamping voltage
I_{PP}	Maximum peak pulse current
I_R	Reverse leakage current @ V_{RWM}
C_O	Typical line capacitance ($V_{IO}=0V$, $V_{P,P} = 30\text{mV}$, $f = 1\text{MHz}$)

Table-4 Parameters Description

At $T_A = 25^\circ\text{C}$ unless otherwise noted

Part Number	V_{RWM} (Max.)	V_{BR} (Min.)	$V_{CL}@I=1A$ (Typ.)	I_{PP} (Max.)	$V_{CL}@I=I_{PP}$ (Typ.)	I_R (Max.)	C_O (Typ.)
	(V)	(V)	(V)	(A)	(V)	(μA)	(pF)
ESDA7P60-1U1 M-ES	5.0	6.0	7.0	100	14.0	1.0	1400

Table-5 Electrical Characteristics for All Series

7. Typical Characteristic

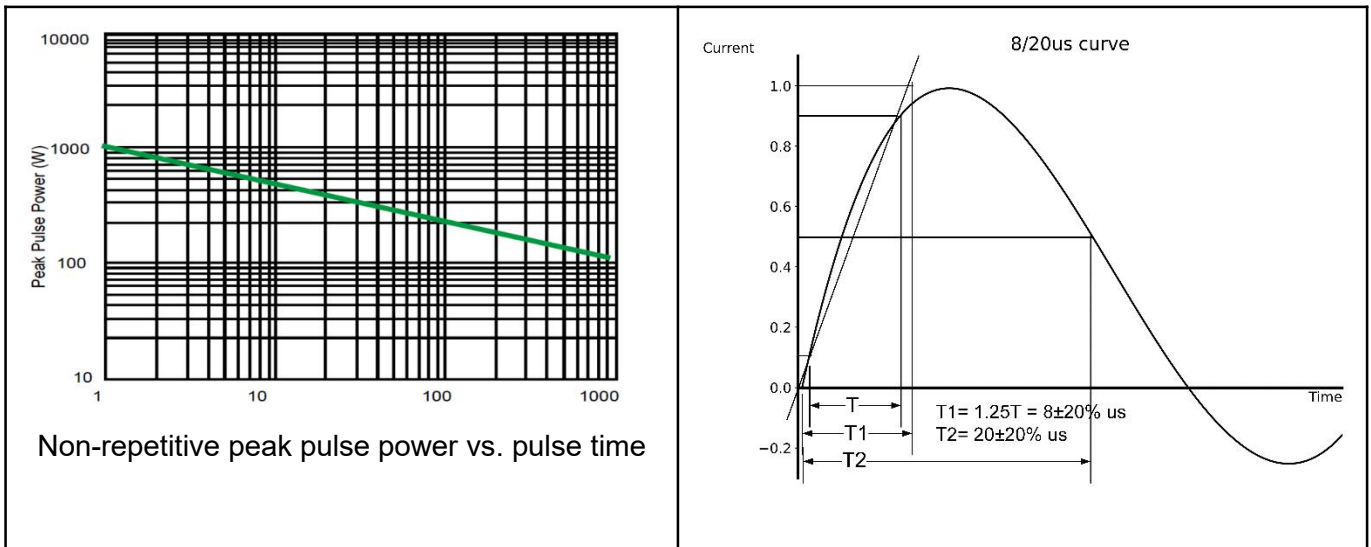

8. Typical Application

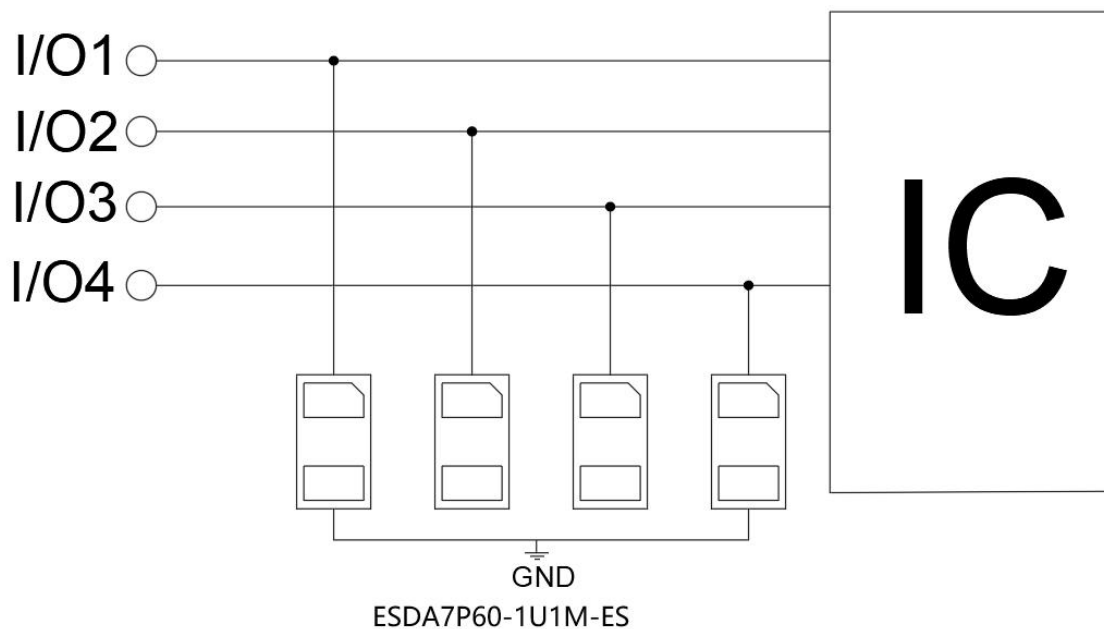

Pic-3 Typical Interface Application

9. Dimension

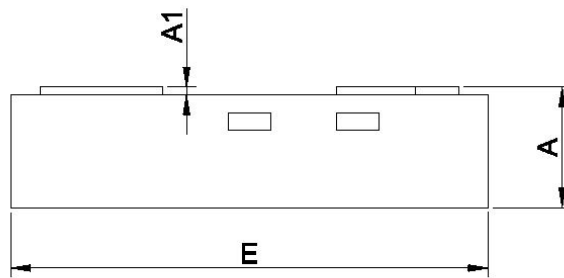
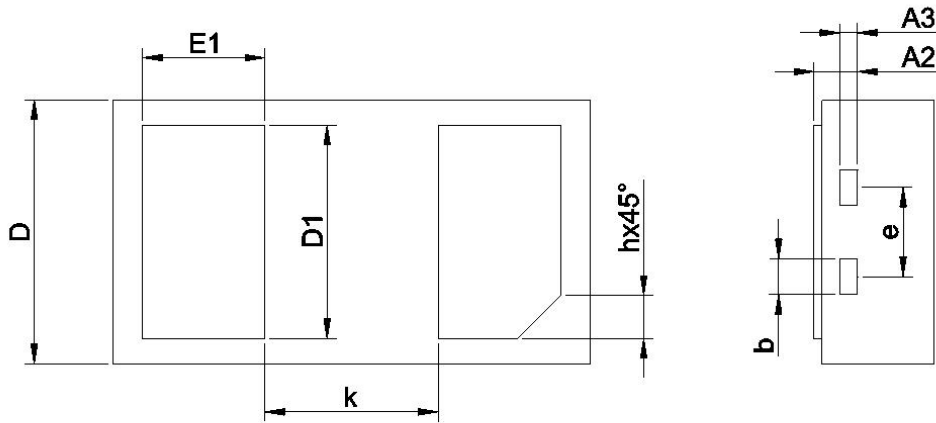

DFN1610-2L



SYMBOL	MIN	NOM	MAX
A	0.400	0.450	0.500
A1	0.000	0.020	0.050
A2	0.077	0.127	0.177
A3	0.0635 BSC		
b	0.100	0.150	0.200
D	0.950	1.000	1.050
D1	0.750	0.800	0.850
E	1.550	1.600	1.650
E1	0.350	0.400	0.450
e	0.400	0.450	0.500
h	0.150	0.200	0.250
k	0.650	0.700	/

Table-6 product dimensions

10. Recommended Soldering Footprint

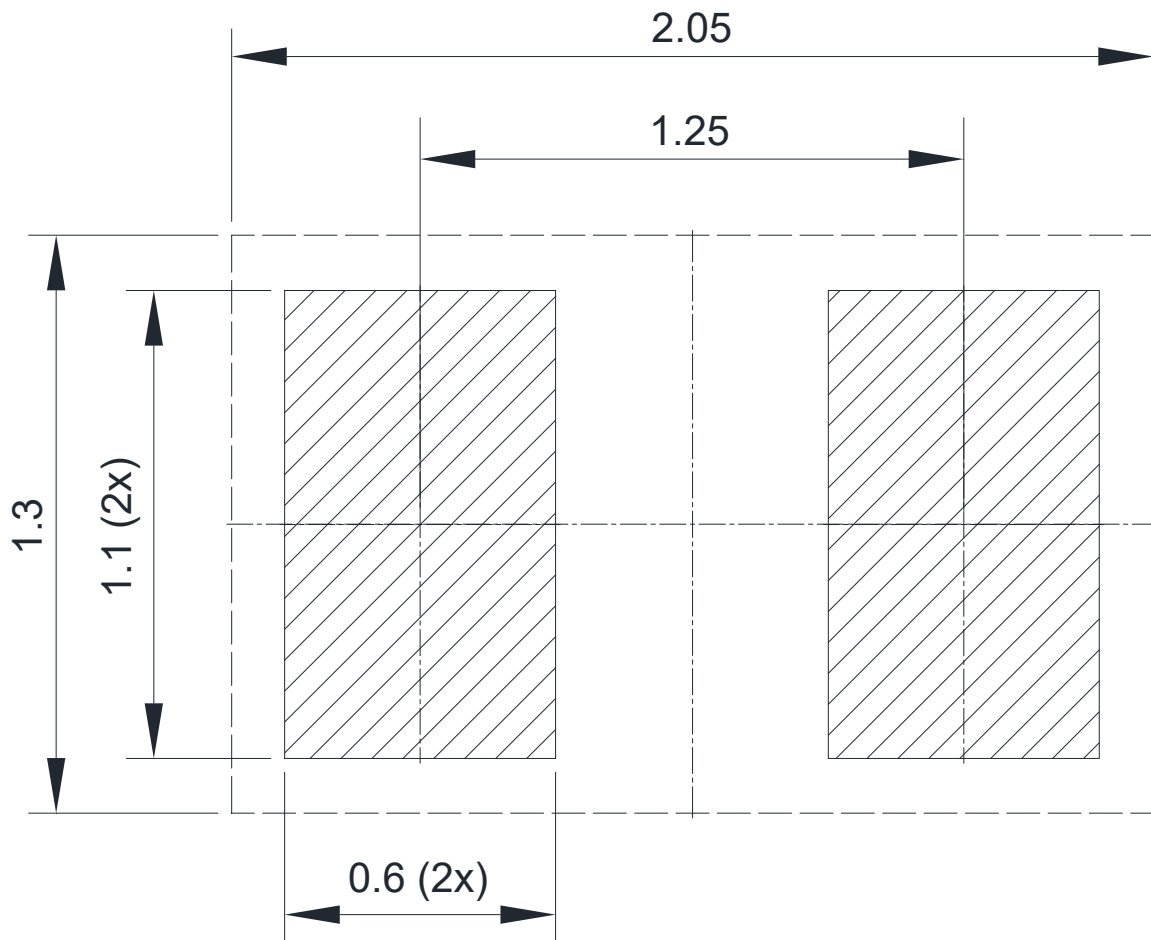

DIMENSIONS: MILLIMETERS

DISCLAIMER

ELECSUPER PROVIDES TECHNICAL AND RELIABILITY DATA (INCLUDING DATASHEETS), DESIGN RESOURCES (INCLUDING REFERENCE DESIGNS), APPLICATION OR OTHER DESIGN ADVICE, SAFETY INFORMATION, AND OTHER RESOURCES "AS IS" AND WITH ALL FAULTS, AND DISCLAIMS ALL WARRANTIES, EXPRESS AND IMPLIED, INCLUDING WITHOUT LIMITATION ANY IMPLIED WARRANTIES OF MERCHANTABILITY, FITNESS FOR A PARTICULAR PURPOSE OR NON-INFRINGEMENT OF THIRD PARTY INTELLECTUAL PROPERTY RIGHTS.

These resources are intended for skilled developers designing with ElecSuper products. You are solely responsible for

- (1) selecting the appropriate ElecSuper products for your application;
- (2) designing, validating and testing your application;
- (3) ensuring your application meets applicable standards, and any other safety, security, or other requirements.

These resources are subject to change without notice. ElecSuper grants you permission to use these resources only for development of an application that uses the ElecSuper products described in the resource. Other reproduction and display of these resources are prohibited. No license is granted to any other ElecSuper intellectual property right or to any third party intellectual property right. ElecSuper disclaims responsibility for, and you will fully indemnify ElecSuper and its representatives against, any claims, damages, costs, losses, and liabilities arising out of your use of these resources. ElecSuper's products are provided subject to ElecSuper's Terms of Sale or other applicable terms available either on www.elecsuper.com or provided in conjunction with such ElecSuper products. ElecSuper's provision of these resources does not expand or otherwise alter ElecSuper's applicable warranties or warranty disclaimers for ElecSuper products.