

TDS:EMIC

拓電半導體

自主封測 品質把控 售後保障

WEB | WWW.TDSEMIC.COM 



電源管理



顯示驅動

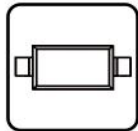

二三極管

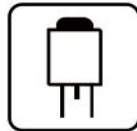

LDO穩壓器

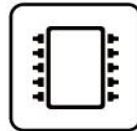

觸摸芯片

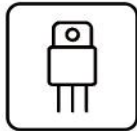

MOS管



運算放大器

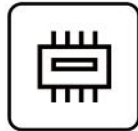

存儲芯片



MCU

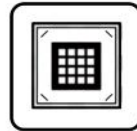

串口通信

MAX483EESA-TD

產品規格說明書

Features:

- ◆ 3.3V power supply, half-duplex;
- ◆ 1/8 unit load allows up to 32 devices on the bus;
- ◆ Driver output short-circuit protection function;
- ◆ Over temperature protection function;
- ◆ Low power shutdown function;
- ◆ Receiver open circuit protection function;
- ◆ Strong anti-noise ability;
- ◆ Integrated transient voltage resistance function;
- ◆ Transmission rate up to 10Mbps in an electrical noise environment

;

Description

The MAX483EESA-TD is a 3.3V powered, half-duplex, low-power RS-485 transceiver that fully meets the requirements of the TIA/EIA-485 standard.

The MAX483EESA-TD includes a driver and a receiver, both of which can be independently enabled and disabled. When both are disabled, both the driver and the receiver output a high impedance state. The MAX483EESA-TD has a 1/8 load that allows 32 MAX483EESA-TD transceivers to be connected to the same communication bus. Error-free data transfer of up to 10Mbps is possible.

The MAX483EESA-TD operates from a voltage range of 3.0 to 3.6V and features fail-safe, over temperature protection, current limit protection, over-voltage protection, and other functions.

Pin configuration

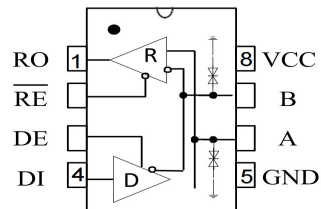

Figure 1 MAX483EESA-TD pin configuration

Limiting values

Parameter	Symbol	Value	Unit
Supply voltage	VCC	+7	V
Voltage of control port	/RE, DE, DI	-0.3~+7	V
Bus side input voltage	A, B	-7~13	V
Receiver output voltage	RO	-0.3~+7	V
Operating temperature range		0~85	°C
Storage temperature range		-60~150	°C
Welding temperature		300	°C
Continuous power dissipation	SOP8	400	mW

The maximum limit parameter value means that exceeding these values may cause irreversible damage to the device. Under these conditions, it is not conducive to the normal operation of the device. Continuous operation of the device under the maximum allowable rating may affect the reliability of the device. The reference point of all voltages is ground.

Pin functions

Pin number	Pin name	Pin function
1	RO	Receiver output When /RE is low level: if A-B \geq 200mV, RO = high; if A-B \leq -200mV, RO = low
2	/RE	Receiver output enable control When /RE is low level, receiver output is enabled, and RO output is available. When /RE is high level, receiver output is disabled, and RO is in high impedance state. When /RE is high level and DE is low level, the device enters low power consumption mode.
3	DE	Driver output enable control When DE is high level, driver output is available; when DE is low level, the output is in high impedance state. When /RE is high level and DE is low level, the device enters low power consumption mode.
4	DI	Driver input When DE is high level, the DI low level forces the non-inverting driver output A low and inverting driver output B high; The DI high level forces the non-inverting driver output A high and inverting driver output B low.
5	GND	Ground
6	A	Non-inverting receiver input and non-inverting driver output
7	B	Inverting receiver input and inverting driver output
8	VCC	Power supply

Driver electrical characteristics

Parameter	Symbol	Test Conditions	Min	Typ	Max	Unit
Differential output voltage (no load)	V_{OD1}			3.3		V
Differential output voltage	V_{OD2}	Figure 2, $R_L = 54 \Omega$	1.5		VCC	V
		Figure 2, $R_L = 100 \Omega$	2		VCC	
Change in magnitude of differential output voltage (NOTE1)	ΔV_{OD}	Figure 2, $R_L = 54 \Omega$			0.2	V
Common mode output voltage	V_{OC}	Figure 2, $R_L = 54 \Omega$			3	V
Change in magnitude of common mode output voltage (NOTE1)	ΔV_{OC}	Figure 2, $R_L = 54 \Omega$			0.2	V
Input high voltage	V_{IH}	DE, DI, /RE	2.0			V
Input low voltage	V_{IL}	DE, DI, /RE			0.8	V
Logic input current	I_{IN1}	DE, DI, /RE	-2		2	μA
Output short-circuit current, short-circuit to high	I_{OSD1}	Short-circuit to 0V~12V			250	mA
Output short-circuit current, short-circuit to low	I_{OSD2}	Short-circuit to -7V~0V	-250			mA
Thermal shutdown threshold				140		$^{\circ}C$
Thermal shutdown hysteresis				20		$^{\circ}C$

(unless otherwise stated $V_{CC}=3.3V \pm 10\%$, $Temp=T_{MIN} \sim T_{MAX}$, typical value is $V_{CC}=+3.3V$, $Temp=25^{\circ}C$)

NOTE1: ΔV_{OD} and ΔV_{OC} are the changes in V_{OD} and V_{OC} amplitude caused by a change of DI state of the input signal.

Receiver electrical characteristics

Parameter	Symbol	Test Conditions	Min	Typ	Max	Unit
Input current (A, B)	I_{IN2}	DE = 0 V, VCC=0 or 3.3V VIN = 12 V			125	μA
		DE = 0 V, VCC=0 or 3.3V VIN = -7 V	-100			μA

Positive-going input threshold voltage	V_{IT+}	$-7V \leq V_{CM} \leq 12V$			+200	mV
Negative-going input threshold voltage	V_{IT-}	$-7V \leq V_{CM} \leq 12V$	-200			mV
Hysteresis voltage	V_{hys}	$-7V \leq V_{CM} \leq 12V$	10	30		mV
High level output voltage	V_{OH}	$I_{OUT} = -2.5mA,$ $V_{ID} = +200 mV$	$V_{CC}-1.5$			V
Low level output voltage	V_{OL}	$I_{OUT} = +2.5mA,$ $V_{ID} = -200 mV$			0.4	V
Tristate leakage current	I_{OZR}	$0.4V < V_O < 2.4V$			± 1	μA
Receiver input resistance	R_{IN}	$-7V \leq V_{CM} \leq 12V$	96			k Ω
Receiver short-circuit current	I_{OSR}	$0V \leq V_O \leq V_{CC}$	± 8		± 60	mA

(unless otherwise stated $V_{CC}=3.3V \pm 10\%$, $Temp=T_{MIN} \sim T_{MAX}$, typical value is $V_{CC}=+3.3V$, $Temp=25^{\circ}C$)

Supply current

Parameter	Symbol	Test conditions	Min	Typ	Max	Unit
Supply current	I_{CC1}	/RE = 0V, DE = 0V		520	800	μA
	I_{CC2}	/RE = VCC, DE = VCC		540	700	μA

Driver switching characteristics

Parameter	Symbol	Test conditions	Min	Typ	Max	Unit
Driver differential output delay	t_{DD}	$R_{DIFF} = 60 \Omega,$ $C_{L1}=C_{L2}=100pF$ (see Figure 3 and Figure 4)		10	35	ns
Driver differential output transition time	t_{TD}			12	25	ns
Driver propagation delay, low-to-high	t_{PLH}	$R_{DIFF} = 27 \Omega,$ (see Figure 3 and Figure 4)		8	35	ns
Driver propagation delay, high-to-low	t_{PHL}			8	35	ns

$ t_{PLH} - t_{PHL} $	t_{PDS}		1	8	ns
Driver enable to output high	t_{PZH}	$R_L = 110\Omega$, (see Figure 5, 6)	20	90	ns
Driver enable to output low	t_{PZL}		20	90	ns
Driver disable time from low	t_{PLZ}	$R_L = 110\Omega$, (see Figure 5,6)	20	80	ns
Driver disable time from high	t_{PHZ}		20	80	ns
Driver enable from shutdown to output high	t_{DSH}	$R_L = 110\Omega$, (see Figure 5,6)	500	900	ns
Driver enable from shutdown to output low	t_{DSL}	$R_L = 110\Omega$, (see Figure 5,6)	500	900	ns

Receiver switching characteristics

Parameter	Symbol	Test Conditions	Min	Typ	Max	Unit
Receiver input to output delay (low to high)	t_{RPLH}	$C_L = 15pF$ See Figure 7 and Figure 8		80	150	ns
Receiver input to output delay (high to low)	t_{RPHL}			80	150	ns
$ t_{RPLH} - t_{RPHL} $	t_{RPDS}				7	10
Receiver enable to output low	t_{RPZL}	$C_L = 15pF$ See Figure 7 and Figure 8		20	50	ns
Receiver enable to output high	t_{RPZH}	$C_L = 15pF$ See Figure 7 and Figure 8		20	50	ns
Receiver disable time from low	t_{PRLZ}	$C_L = 15pF$ See Figure 7 and Figure 8		20	45	ns
Receiver disable time from high	t_{PRHZ}	$C_L = 15pF$ See Figure 7 and Figure 8		20	45	ns
Receiver enable from shutdown to output high	t_{RPSH}	$C_L = 15pF$ See Figure 7 and Figure 8		200	1400	ns
Receiver enable from shutdown to output low	t_{RPSL}	$C_L = 15pF$ See Figure 7 and Figure 8		200	1400	ns
Time to shutdown	t_{SHDN}	NOTE2	80		300	ns

NOTE2: The device is put into shutdown by bringing RE high and DE low. If the enable inputs are in this state for less than 80ns, the device is guaranteed not to enter shutdown. If the enable inputs are in this state for at least 300ns, the device is guaranteed to have entered shutdown.

Function table

Driver

Control		Input	Output	
/RE	DE	DI	A	B
X	1	1	H	L
X	1	0	L	H
0	0	X	Z	Z
1	0	X	Z (shutdown)	
X: don't care; Z: high impedance				

Receiver

Control		Input	Output
/RE	DE	A-B	RO
0	X	$\geq 200\text{mV}$	H
0	X	$\leq -200\text{mV}$	L
0	X	Open/short-circuit	H
1	X	X	Z
X: don't care; Z: high impedance			

Test circuit

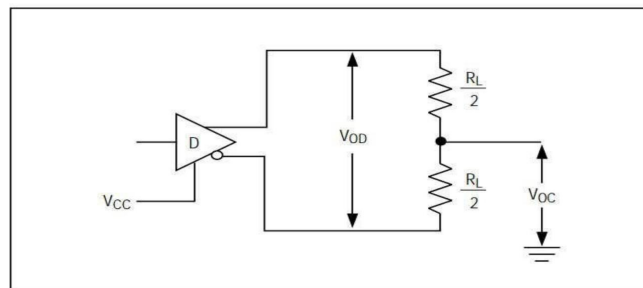

Fig. 2 Driver DC test load

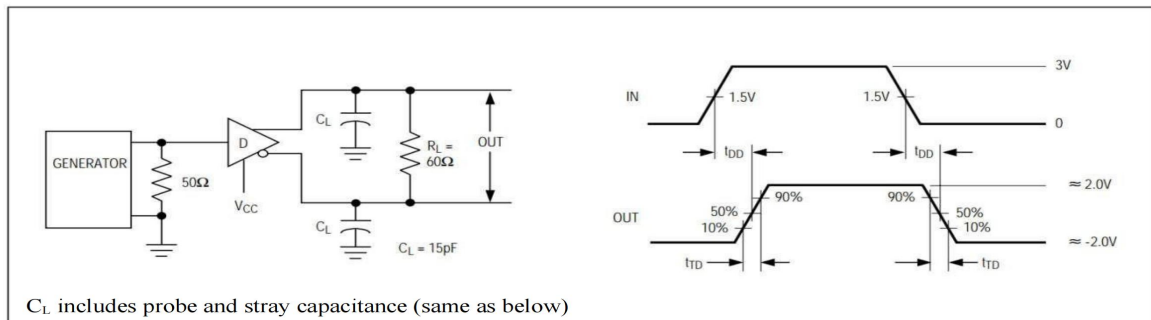

Fig. 3 Driver differential output delay and transition times

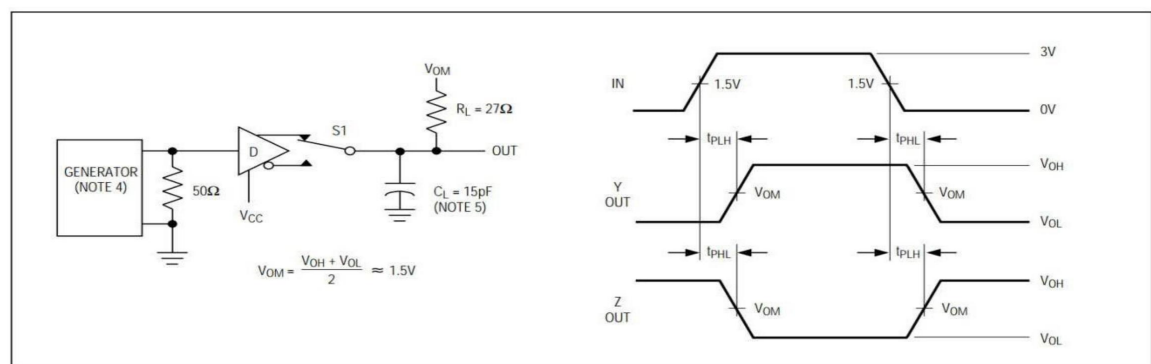

Fig. 4 Driver propagation times

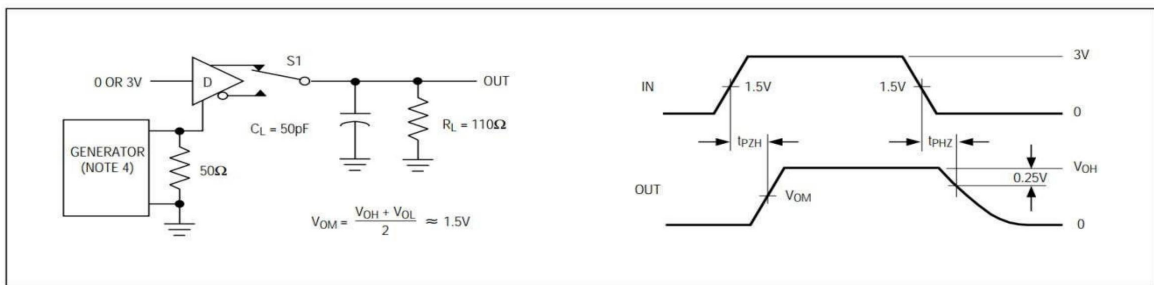

Fig. 5 Driver enable and disable times

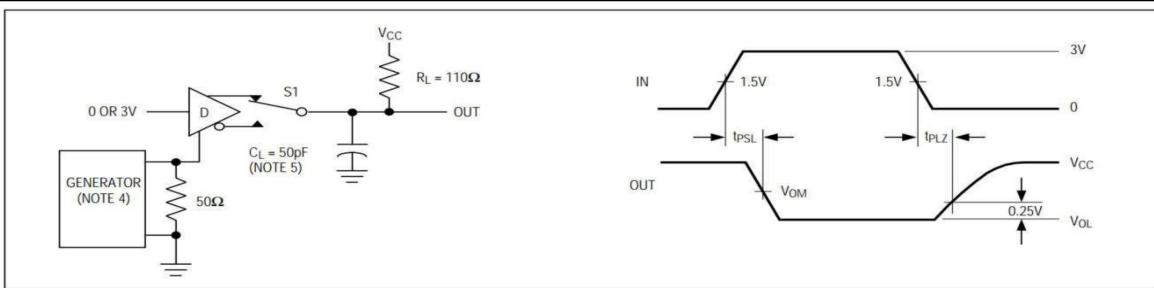
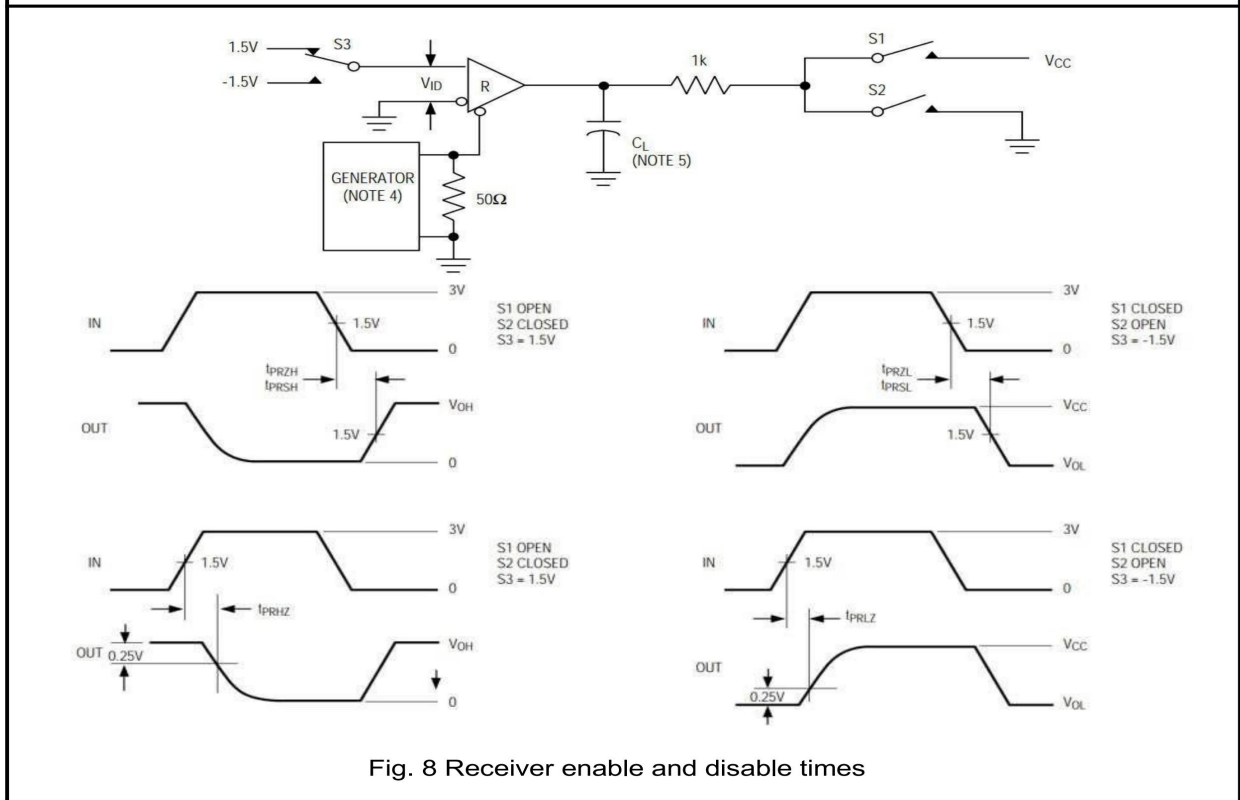
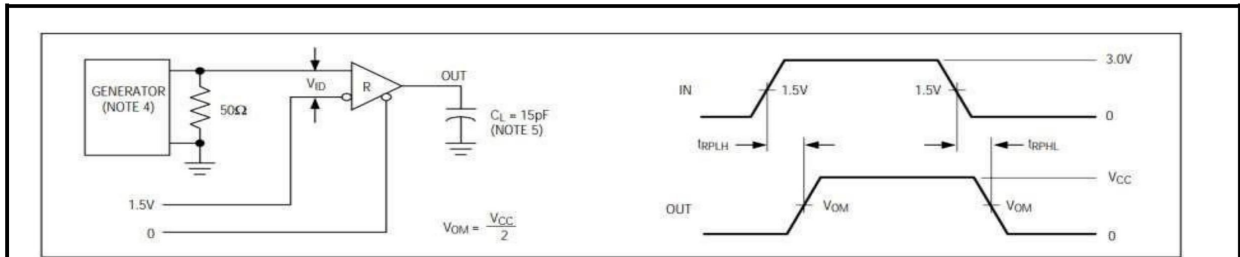

Fig. 6 Driver enable and disable times



General description

1 Brief description

The MAX483EESA-TD is a half-duplex high-speed transceiver for RS-485/RS-422 communication, and includes one driver and one receiver. It has fail-safe, over-voltage protection and over-current protection. The MAX483EESA-TD allows error-free data transmission up to 10Mbps.

2 Allowing up to 32 transceivers on the bus

The standard RS-485 receiver has an input impedance of 12k Ω (1 unit load), and the standard driver can drive up to 32 unit loads. The receiver of the MAX483EESA-TD transceiver has a 1/8 unit load receiver input impedance (96k Ω), allowing up to 32

transceivers to be connected in parallel on one bus. These devices can be combined arbitrarily, or combined with other RS-485 transceivers, as long as the total load does not exceed 32 units.

3 Driver output protection

Two mechanisms are used to avoid faults or bus collisions that cause excessive output current and excessive power consumption. First, over-current protection provides fast short-circuit protection over the entire common-mode voltage range (refer to the typical operating characteristics). Second, the thermal shutdown circuit forces the driver output into a high-impedance state when the die temperature exceeds 140°C.

4 Typical applications

4.1 Bus networking: The MAX483EESA-TD RS485 transceiver is designed for bidirectional data communication on multi-point bus transmission lines. Figure 9 shows a typical network application circuit. These devices can also be used

as linear repeaters with cables longer than 4000 feet. In order to reduce reflections, terminal matching should be done at both ends of the transmission line with their characteristic impedance, and the length of the branch wires other than the main line should be as short as possible.

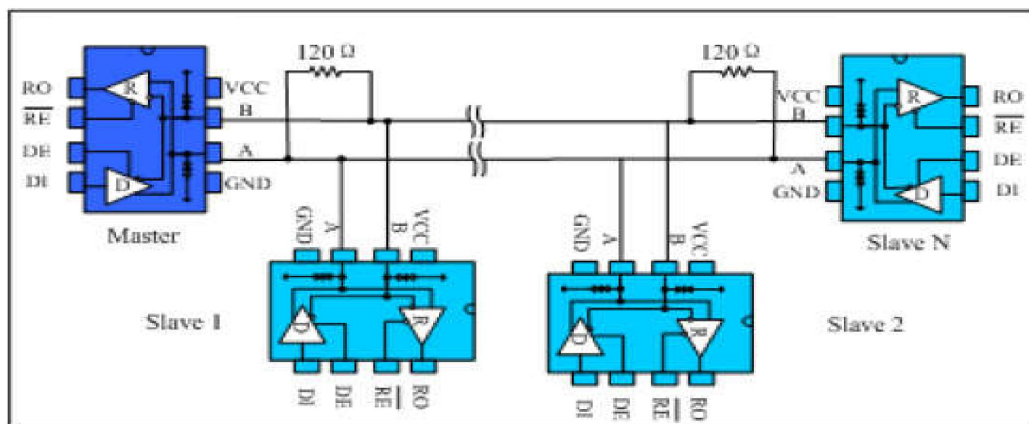

Fig. 9 Bus-type RS485 half-duplex communication network

4.2 Hand-in-hand networking: Also known as daisy chain topology, it is the standard and specification of RS485 bus wiring, and is the RS485 bus topology recommended by organizations such as TIA. The wiring method is that the master control device and multiple slave devices form a hand-in-hand connection, as shown in Figure 10, the hand-in-hand way is to leave no branches. This wiring method has the advantages of low signal reflection and high communication success rate.

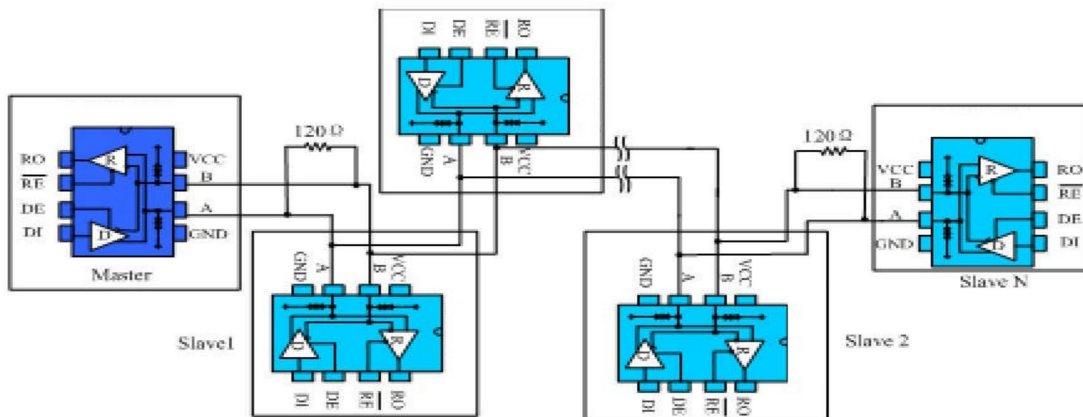

Fig. 10 Hand-in-hand type RS485 half-duplex communication network

4.3 Bus port protection : In harsh environments, RS485 communication ports are usually protected against static electricity, lightning and surge protection, etc. and it is even necessary to prevent 380V power supply access to avoid damage of smart meters and industrial control hosts. Figure 11 shows 3 common kinds of RS485 bus port protection schemes. The first scheme is to connect the TVS device to the protection ground in parallel with the AB port, the TVS device in parallel with the AB port, the thermistor in series with the AB port and the gas discharge tube is connected to the protection ground to form a three-level protection scheme. The second scheme is a three-level protection scheme including TVS connected to the ground in parallel with AB, the thermistor in series and the varistor in parallel with AB. The third one includes pull-down resistors connected to the power supply and ground respectively for AB, TVS between AB and the thermistor connected to A or B port.

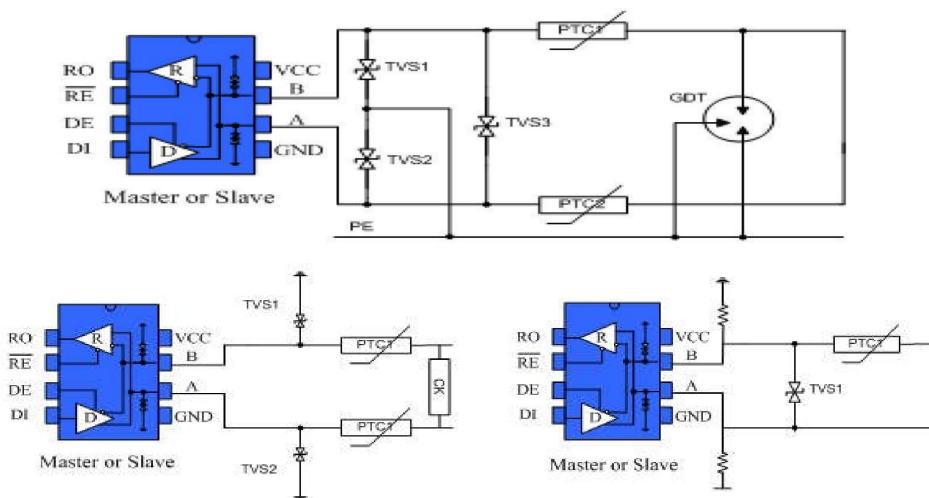
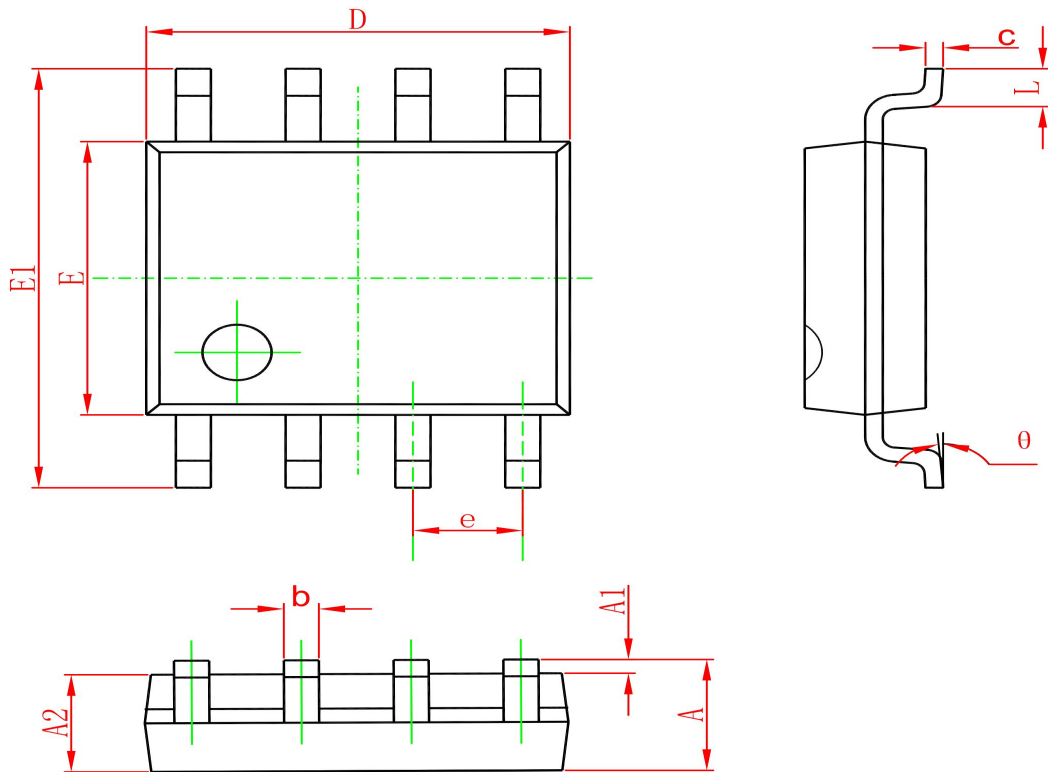

Fig. 11 Port protection scheme

SOP-8



Symbol	Dimensions In Millimeters		Dimensions In Inches	
	Min	Max	Min	Max
A	1.350	1.750	0.053	0.069
A1	0.100	0.250	0.004	0.010
A2	1.350	1.550	0.053	0.061
b	0.330	0.510	0.013	0.020
c	0.170	0.250	0.006	0.010
D	4.700	5.100	0.185	0.200
E	3.800	4.000	0.150	0.157
E1	5.800	6.200	0.228	0.244
e	1.270(BSC)		0.050(BSC)	
L	0.400	1.270	0.016	0.050
θ	0°	8°	0°	8°

Ordering information

Order code	Package	Baseqty	Deliverymode
MAX483EESA-TD	SOP-8	2500	Tape and reel