



SPECIFICATIONS

Rated Current:3.0AMP
 Contact Resistance:20mΩ Max
 Withstand Voltage:1000V AC/DC
 Insulation Resistance:1000MΩ Min
 Operation Temperature:-40°C to +105°C

Contact Material:Brass
 Contact Plating:Au Over Ni
 Insulator Material:Polyester(UL94V-0)
 Standard: PA6T
 Max.Processing Temp: 230°C for 30-60 seconds
 (260°C for 10 seconds)

Recommended P.C.B Layout(Top Side)
 (PCB BOARD TOLERANCE±0.05)

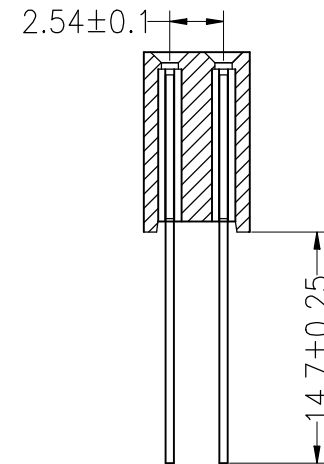
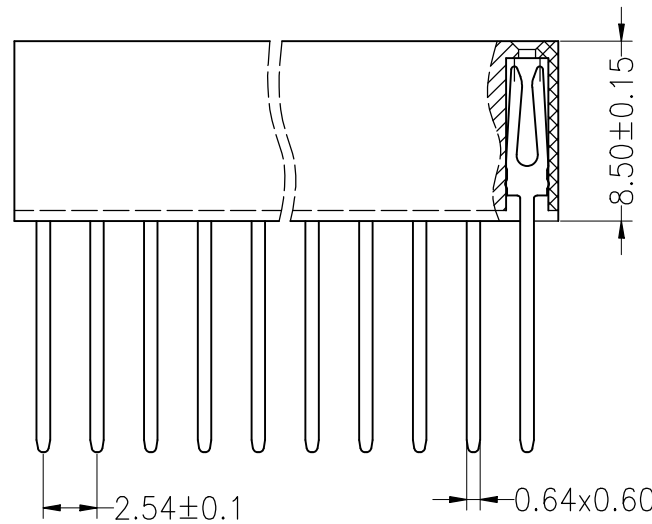
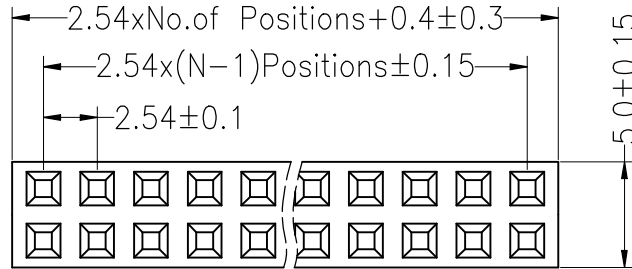
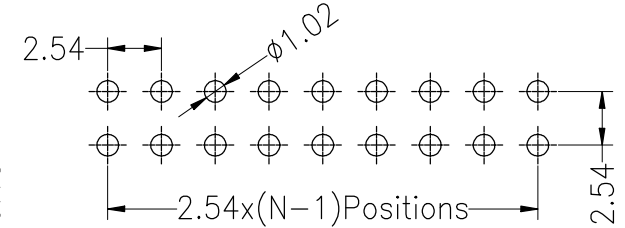

Ordering Information

2285 02 XX X N XX S Y X 0X

- | | | | |
|-------------------------|--|---|---|
| No.of Pins Per Row 2*40 | Insulator Material Option A=BK-PBT C=BK-PA6T D=BK-PA46 E=BK-PA9T F=BK-LCP | Contact Plating G1:1U" Gold G2:1.5U" Gold G3:2U" Gold G4:3U" Gold G5:5U" Gold S0:Gold Flash/Tin SN:Tin | Packing O=PE Bag A=Tray T=Tube P=Tube+Cap R=Reel+Cap M=Reel+Mylar |
|-------------------------|--|---|---|

| | | | | | | | | | | | | | |
|-----|------------|--------------------------|--|-----------|-------|---------|-----------|----------|----------|--|--|--|--|
| | | | | OPERATION | | DRAW | YiYuSheng | 12.03.28 | SCALE | FIT | JILN ® 深圳锦凌电子股份有限公司 SHENZHEN JINLING ELECTRONICS CO.,LTD Tel: 86-755-27483253 Fax: 86-755-2997-5588 | | |
| | | | | X.X | ±0.30 | | | | UNIT | mm | | | |
| | | | | X.XX | ±0.20 | CHECK | SIZE | A4 | PART NO. | 228502XXXXXXSYX0X | | | |
| A0 | 2012.03.28 | NEW DRAWING | | X.XXX | ±0.10 | APPROVE | SHEET | 1/1 | TITLE: | 2.54PF H8.5mm 2xNpin 180° W5.0mm PC104 L21.8 | | | |
| REV | DATE | MODIFICATION DESCRIPTION | | CHANGE | DIM | TOL | PROJ. | | | | | | |