

# HC-COM-HHFS-1TTM25-EL-AL - Housing



1078590

<https://www.phoenixcontact.com/us/products/1078590>

Please be informed that the data shown in this PDF document is generated from our online catalog. Please find the complete data in the user documentation. Our general terms of use for downloads are valid.



Sleeve housing COM, for single locking latch, material: Die-cast aluminum, salt water resistant, cable outlets: 1, straight, 1x M25, height: 68 mm, cable gland: none, Standard

## Your advantages

- Good shielding in the event of electromagnetic interference

## Commercial data

Item number	1078590
Packing unit	1 pc
Minimum order quantity	1 pc
Sales key	BF59
Product key	BF7APP
Catalog page	Page 653 (C-2-2019)
GTIN	4055626791890
Weight per piece (including packing)	83.7 g
Weight per piece (excluding packing)	83 g
Customs tariff number	85389099
Country of origin	CN

# HC-COM-HHFS-1TTM25-EL-AL - Housing

1078590

<https://www.phoenixcontact.com/us/products/1078590>

## Technical data

### Product properties

Product type	Housing with locking latch
Housing type	Sleeve housing
Product family	HC-COM
Application	Standard
Type	COM
No. of cable outlets	1
Type of the screw connection	1x M25
Type	Tall design
Cable outlet	straight
Pg screw connection	none

### Data management status

Article revision	01
------------------	----

### Dimensions

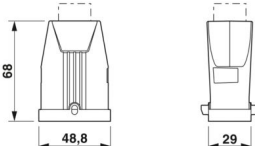
Dimensional drawing	
Width	39 mm
Height	68 mm
Length	48.8 mm

### Material specifications

Housing material	Die-cast aluminum, salt water resistant
------------------	---

### Mechanical properties

#### Mechanical data

Type of the screw connection	1x M25
Locking type	Pin

### Environmental and real-life conditions

#### Ambient conditions

Degree of protection	IP66
Impact strength	IK06
Ambient temperature (operation)	-40 °C ... 125 °C

# HC-COM-HHFS-1TTM25-EL-AL - Housing

1078590

<https://www.phoenixcontact.com/us/products/1078590>



## Drawings

Dimensional drawing

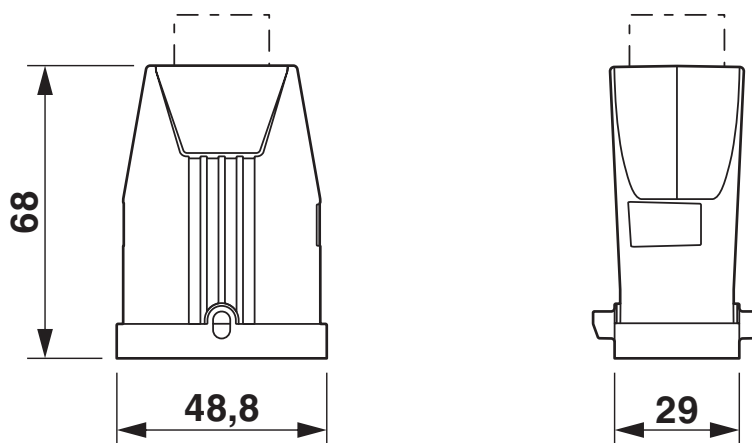

# HC-COM-HHFS-1TTM25-EL-AL - Housing



1078590

<https://www.phoenixcontact.com/us/products/1078590>

## Approvals

To download certificates, visit the product detail page: <https://www.phoenixcontact.com/us/products/1078590>



**cUL Recognized**  
Approval ID: E255026



**UL Recognized**  
Approval ID: E255026

**cULus Recognized**

1078590

<https://www.phoenixcontact.com/us/products/1078590>

## Classifications

### ECLASS

ECLASS-11.0	27440202
ECLASS-12.0	27440202
ECLASS-13.0	27440202

### ETIM

ETIM 9.0	EC000437
----------	----------

### UNSPSC

UNSPSC 21.0	31261500
-------------	----------

1078590

<https://www.phoenixcontact.com/us/products/1078590>

## Environmental product compliance

### EU RoHS

Fulfills EU RoHS substance requirements	Yes, No exemptions
---	--------------------

### China RoHS

Environment friendly use period (EFUP)	EFUP-E
	No hazardous substances above the limits

### EU REACH SVHC

REACH candidate substance (CAS No.)	No substance above 0.1 wt%
-------------------------------------	----------------------------

Phoenix Contact 2024 © - all rights reserved

<https://www.phoenixcontact.com>

Phoenix Contact USA  
586 Fulling Mill Road  
Middletown, PA 17057, United States  
(+717) 944-1300  
[info@phoenixcon.com](mailto:info@phoenixcon.com)