

标记 MARK	ECN编号/变更内容 ECN NO/DEFINITION	修改 REVISE	日期 DATE	核准 APPROVE

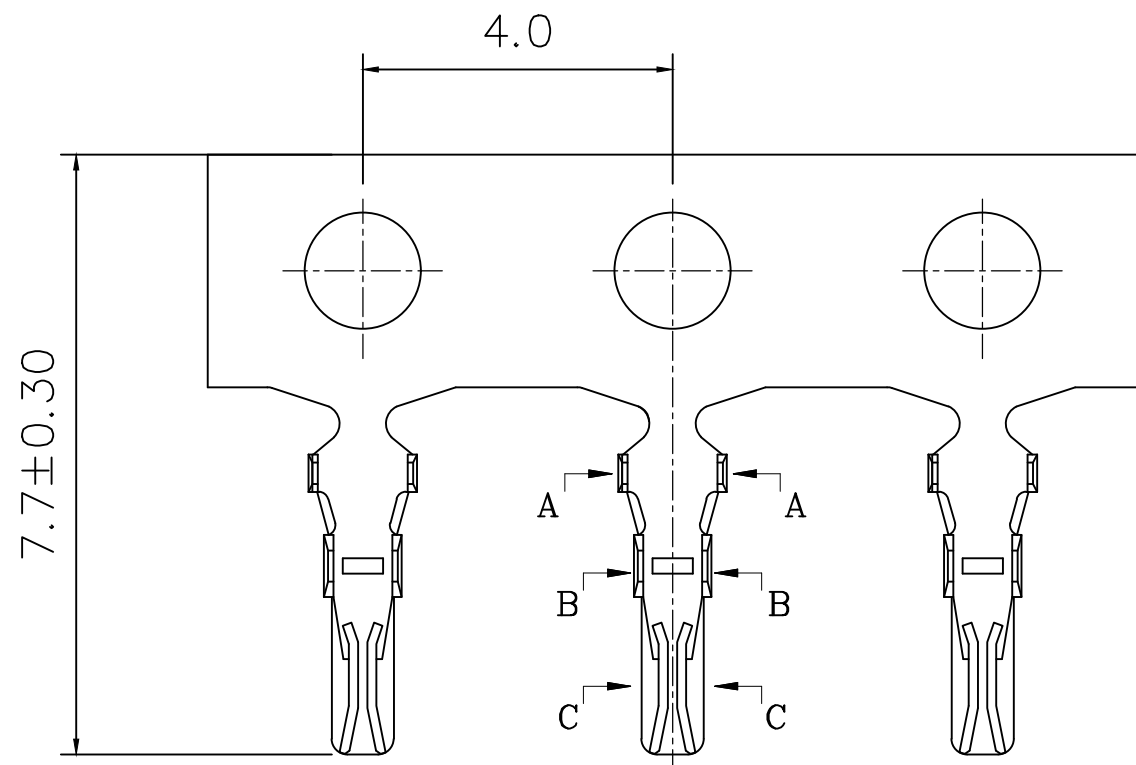

技术指标:

1. 温度范围: $-25^{\circ}\text{C} \sim 85^{\circ}\text{C}$
2. 额定电压: 50V, DC/AC(rms)
3. 额定电流: 1.0A
4. 接触电阻: $\leq 20\text{m}\Omega$
5. 绝缘电阻: $\geq 100\text{M}\Omega$
6. 耐压: 250V AC/minute
7. 适用线规: AWG#28~#32

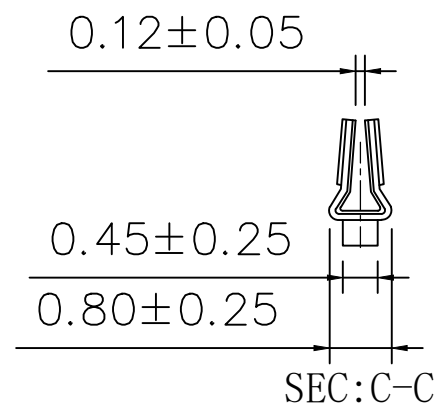
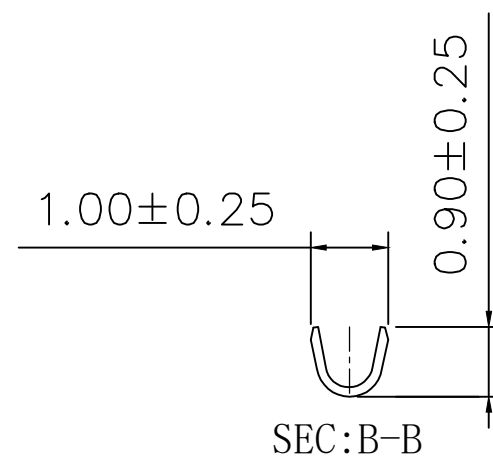
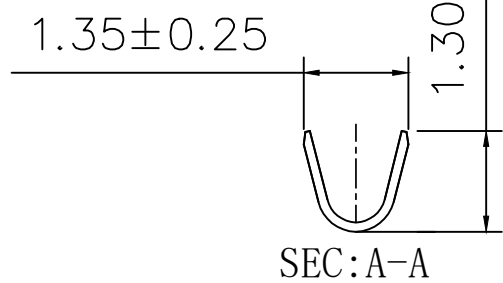
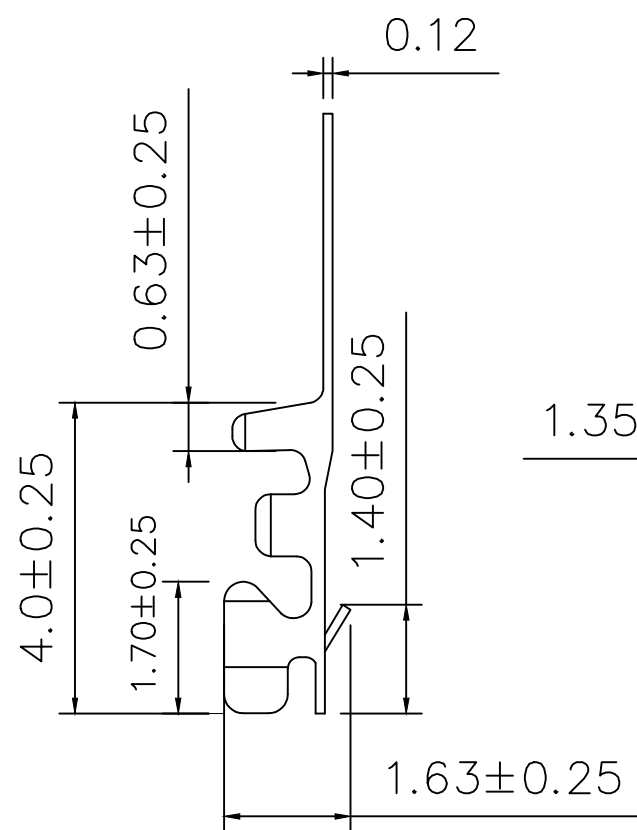

1	端子	铜	镀锡	
序号	品名	材质	电镀/颜色	备注

	深圳市虹成电子有限公司		品名 TITLE	端子
			料号 PART NO	HC-DZ-SHB1.0

GENERAL TOLERANCES (UNLESS SPECIFIED)		比列 SCALE	1:1		
X. ±0.50	.XX ±0.10	单位 UNIT	MM	制图 DRAW	AhYe
.X ±0.20	.XXX ±0.05	张数 PART NO	1 OF 1	审核 CHECKED	夏操云
ANGLES ±1°		版本 REV	A	批准 APPROVE	赵亮亮

