

SCHOTTKY BARRIER RECTIFIER

Reverse Voltage - 200 V

Forward Current - 30 A

FEATURES

- ◆The plastic package carries Underwriters Laboratory Flammability Classification 94V-0
- ◆Construction utilizes void-free molded plastic technique
- ◆Low reverse leakage
- ◆High forward surge current capability
- ◆High temperature soldering guaranteed 250 °C/10 seconds at terminals

MECHANICAL DATA

- ◆Case: TO-252
- ◆Terminals : Solder plated, solderable per MIL-STD-750,Method 2026
- ◆Polarity : Polarity symbol marking on body
- ◆Mounting Position : Any

Primary Characteristic

I_o	2*15A
V_{RRM}	200V
I_{FSM}	175A
V_F	0.85V
T_J Max	150°C

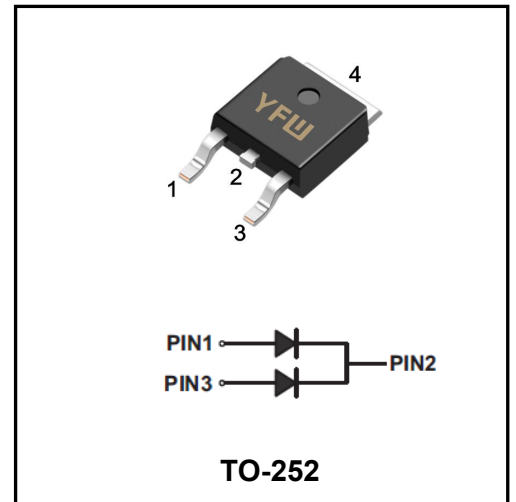

Maximum Ratings (Per Leg) at Ta=25°C unless otherwise specified

Parameter	Symbols	Value	Units
Maximum Repetitive Peak Reverse Voltage	V_{RRM}	200	V
Maximum RMS voltage	V_{RMS}	140	V
Maximum DC Blocking Voltage	V_{DC}	200	V
Maximum Average Forward Rectified Current	Per Leg	15	A
	Total	30	
Peak Forward Surge Current, 8.3ms Single Half Sine-wave	I_{FSM}	175	A
Operating Temperature Range	T_J	-55 ~ +150	°C
Storage Temperature Range	T_{STG}	-55 ~ +150	°C
Typical Thermal Resistance	R_{θJC}	4.5	°C/W

Electrical Characteristics (Per Leg) unless otherwise specified

Characteristics	Symbols	Value		Units	
Forward Voltage Drop	V_F	Typ	Max	V	
at I _F =3A		TA=25°C	0.70		-
		TA=125°C	0.65		-
at I _F =5A		TA=25°C	0.78		-
		TA=125°C	0.66		-
at I _F =15A		TA=25°C	0.90		0.95
		TA=125°C	0.85		-
Maximum Reverse Current at V _R =200V		I_R	TA=25°C		10
	TA=125°C		1.5	mA	

Ratings And Characteristic Curves

FIG. 1- DERATING CURVE OUTPUT RECTIFIED CURRENT

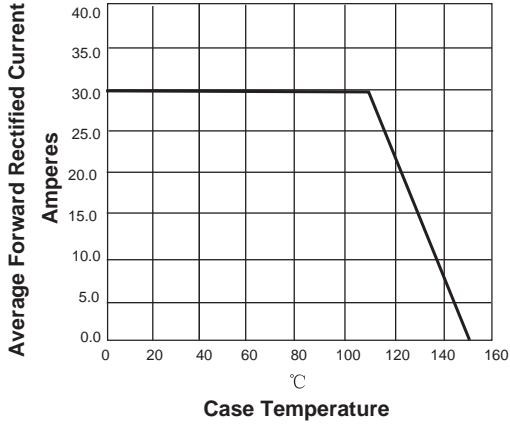

FIG. 2-MAXIMUM NON-REPETITIVE PEAK FORWARD SURGE CURRENT PER LEG

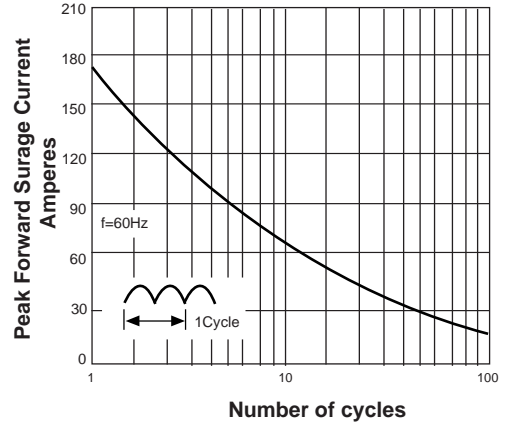

FIG. 3-TYPICAL FORWARD VOLTAGE CHARACTERISTICS

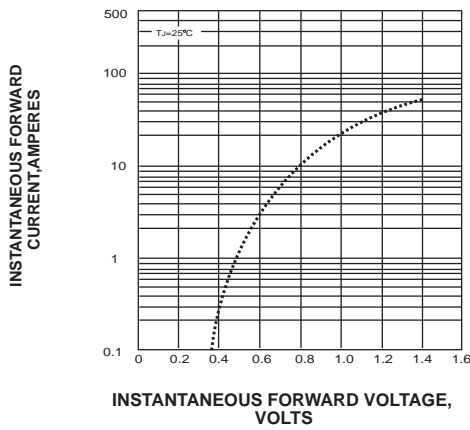
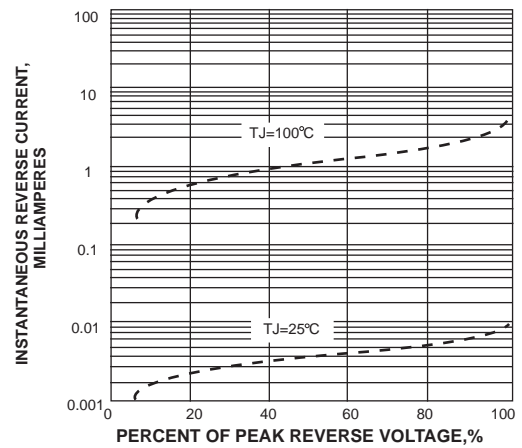
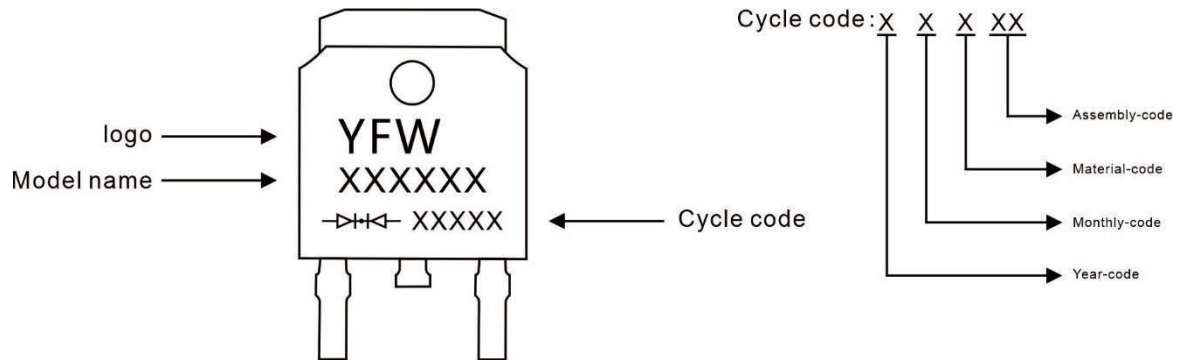

FIG. 4-TYPICAL REVERSE LEAKAGE CHARACTERISTICS



Marking Diagram



Ordering information

Model name	Package	Unit Weight	Base Quantity	Packing Quantity
MBR30200CS	TO-252	0.011oz(0.32g)	2500pcs/reel	5000pcs/box 25000pcs/Carton

Package Dimensions

TO-252

Dim	Millimeter		Inches	
	Min.	Max.	Min.	Max.
A	2.20	2.50	0.087	0.098
A1	0.00	0.12	0.000	0.005
A2	2.20	2.40	0.087	0.094
B	1.20	1.60	0.047	0.063
b	0.50	0.70	0.020	0.028
b1	0.70	0.90	0.028	0.035
c	0.40	0.60	0.016	0.024
c1	0.40	0.60	0.016	0.024
D	6.35	6.65	0.250	0.262
D1	5.20	5.40	0.205	0.213
E	5.40	5.70	0.213	0.224
e	2.20	2.40	0.087	0.094
e1	4.40	4.80	0.173	0.189
L	10.00	11.00	0.393	0.433
L1	2.70	3.10	0.106	0.122
L2	1.40	1.80	0.055	0.071
L3	0.90	1.50	0.035	0.059

Disclaimer

The information presented in this document is for reference only. GuangDong Youfeng Microelectronics Co.,Ltd. reserves the right to make changes without notice for the specification of the products displayed herein to improve reliability, function or design or otherwise. The product listed herein is designed to be used with ordinary electronic equipment or devices, and not designed to be used with equipment or devices which require high level of reliability and the malfunction of with would directly endanger human life (such as medical instruments, transportation equipment, aerospace machinery, nuclear-reactor controllers, fuel controllers and other safety devices),YFW or anyone on its behalf, assumes no responsibility or liability for any damages resulting from such improper use of sale. This publication supersedes & replaces all information previously supplied. For additional information, please visit our website <https://www.yfwdiode.com>, or consult YFW sales office for further assistance.