

Quad 2-Input EXCLUSIVE-NOR Gate

Features

- Wide supply voltage range from 3V to 15V
- Fully static operation
- 5V, 10V, and 15V parametric ratings
- Standardized symmetrical output characteristics
- Specified from -40°C to +85°C
- Packaging information: DIP-14/SOP-14/TSSOP-14/QFN-16

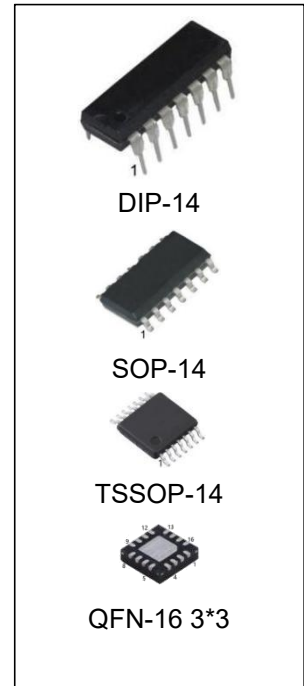

Ordering Information

DEVICE	Package Type	MARKING	Packing	Packing Qty
CD4077BN/HG	DIP-14	CD4077B	TUBE	1000pcs/box
CD4077BM/TR-HG	SOP-14	CD4077B	REEL	2500pcs/reel
CD4077BMT/TR-HG	TSSOP-14	CD4077B	REEL	2500pcs/reel
CD4077BLQ/TR-HG	QFN-16 3*3	CD4077B	REEL	5000pcs/reel

General Description

The CD4077B is a quad 2-input EXCLUSIVE-NOR gate. The outputs are fully buffered for the highest noise immunity and pattern insensitivity to output impedance.

The CD4077B operates over a recommended V_{DD} power supply range of 3V to 15V referenced to V_{SS} (usually ground). Unused inputs must be connected to V_{DD} , V_{SS} , or another input.

Block Diagram

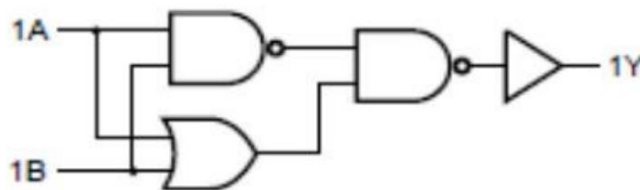
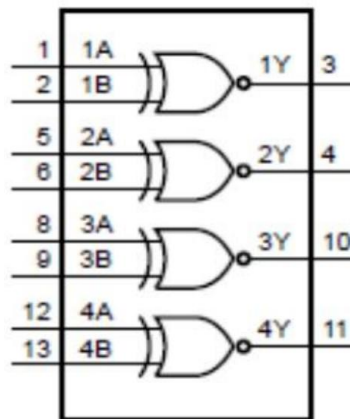

Function Table

Input		Output
nA	nB	nY
L	L	H
L	H	L
H	L	L
H	H	H

Note: H=HIGH voltage level; L=LOW voltage level

Pin Configurations

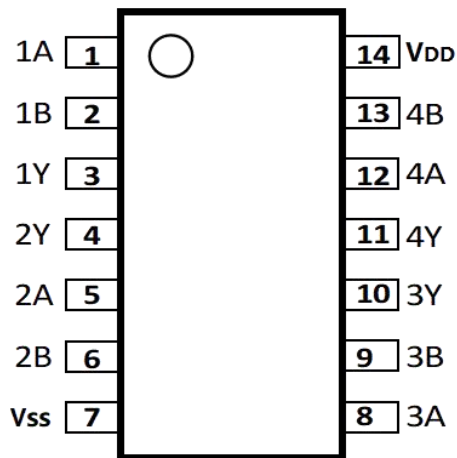

DIP-14/SOP-14/TSSOP-14

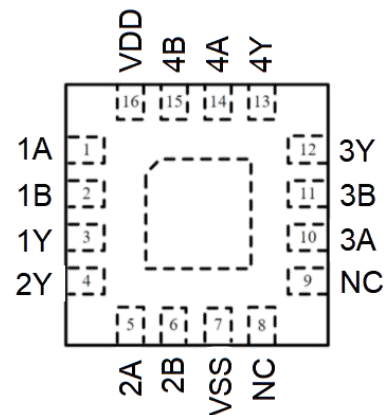

QFN-16 3*3

Pin Description

Pin No.		Pin Name	Description
DIP/SOP/TSSOP	QFN		
1	1	1A	data input
2	2	1B	data input
3	3	1Y	data output
4	4	2Y	data output
5	5	2A	data input
6	6	2B	data input
7	7	VSS	ground (0V)
8	10	3A	data input
9	11	3B	data input
10	12	3Y	data output
11	13	4Y	data output
12	14	4A	data input
13	15	4B	data input
14	16	VDD	supply voltage
-	8	NC	No connection
-	9	NC	No connection

Absolute Maximum Ratings

(Voltages are referenced to VSS (ground=0V), unless otherwise specified.)

Parameter	Symbol	Conditions	Min.	Max.	Unit
supply voltage	V _{DD}	-	-0.5	+18	V
DC input current	I _{IK}	any one input	-	±10	mA
input voltage	V _I	all inputs	-0.5	V _{DD} +0.5	V
storage temperature	T _{stg}	-	-65	+150	°C
Soldering temperature	T _L	10s		260	°C
total power dissipation	P _{tot}	-	-	500	mW
device dissipation	P	per output transistor	-	100	mW

Note: Absolute Maximum Ratings are those values beyond which damage to the device may occur. Functional operation under these conditions is not implied.

For DIP14 packages: above 70°C the value of P_{tot} derates linearly with 12mW/K.

For SOP14 packages: above 70°C the value of P_{tot} derates linearly with 8mW/K.

For (T)SSOP14 packages: above 60°C the value of P_{tot} derates linearly with 5.5mW/K

Recommended Operating Conditions

Parameter	Symbol	Conditions	Min.	Typ.	Max.	Unit
supply voltage	V _{DD}	-	3	-	15	V
ambient temperature	T _{amb}	in free air	-40	-	+85	°C

Electrical Characteristics

DC Characteristics 1

(T_{amb}=25°C, voltages are referenced to VSS (ground=0V), unless otherwise specified.)

Parameter	Symbol	Conditions(V)			T _{amb} =25°C			Unit
		V _O	V _{IN}	V _{DD}	Min.	Typ.	Max.	
supply current	I _{DD}	-	0, 5	5	-	0.01	0.25	μA
		-	0, 10	10	-	0.01	0.5	μA
		-	0, 15	15	-	0.01	1	μA
LOW-level output current	I _{OL}	0.4	0, 5	5	0.51	1	-	mA
		0.5	0, 10	10	1.3	2.6	-	mA
		1.5	0, 15	15	3.4	6.8	-	mA
HIGH-level output current	I _{OH}	4.6	0, 5	5	-0.51	-1	-	mA
		2.5	0, 5	5	-1.6	-3.2	-	mA
		9.5	0, 10	10	-1.3	-2.6	-	mA
		13.5	0, 15	15	-3.4	-6.8	-	mA
LOW-level output voltage	V _{OL}	-	0, 5	5	-	0	0.05	V
		-	0, 10	10	-	0	0.05	V
		-	0, 15	15	-	0	0.05	V
HIGH-level output voltage	V _{OH}	-	0, 5	5	4.95	5	-	V
		-	0, 10	10	9.95	10	-	V
		-	0, 15	15	14.95	15	-	V
LOW-level input voltage	V _{IL}	0.5, 4.5	-	5	-	-	1.5	V
		1, 9	-	10	-	-	3	V
		1.5, 13.5	-	15	-	-	4	V
HIGH-level input voltage	V _{IH}	0.5, 4.5	-	5	3.5	-	-	V
		1, 9	-	10	7	-	-	V
		1.5, 13.5	-	15	11	-	-	V
input leakage current	I _I	-	0, 15	15	-	±10 ⁻⁵	±0.1	μA

DC Characteristics 2

 (T_{amb}=-40°C to +105°C, voltages are referenced to V_{SS} (ground=0V), unless otherwise specified.)

Parameter	Symbol	Conditions(V)			T _{amb} =-40°C		T _{amb} =+85°C		T _{amb} =+105°C		Unit
		V _O	V _{IN}	V _{DD}	Min.	Max.	Min.	Max.	Min.	Max.	
supply current	I _{DD}	-	0, 5	5	-	0.25	-	7.5	-	7.5	μA
		-	0, 10	10	-	0.5	-	15	-	15	μA
		-	0, 15	15	-	1	-	30	-	30	μA
LOW-level output current	I _{OL}	0.4	0, 5	5	0.61	-	0.42	-	0.36	-	mA
		0.5	0, 10	10	1.5	-	1.1	-	0.9	-	mA
		1.5	0, 15	15	4	-	2.8	-	2.4	-	mA
HIGH-level output current	I _{OH}	4.6	0, 5	5	-0.61	-	-0.42	-	-0.36	-	mA
		2.5	0, 5	5	-1.8	-	-1.3	-	-1.15	-	mA
		9.5	0, 10	10	-1.5	-	-1.1	-	-0.9	-	mA
		13.5	0, 15	15	-4	-	-2.8	-	-2.4	-	mA
LOW-level output voltage	V _{OL}	-	0, 5	5	-	0.05	-	0.05	-	0.05	V
		-	0, 10	10	-	0.05	-	0.05	-	0.05	V
		-	0, 15	15	-	0.05	-	0.05	-	0.05	V
HIGH-level output voltage	V _{OH}	-	0, 5	5	4.95	-	4.95	-	4.95	-	V
		-	0, 10	10	9.95	-	9.95	-	9.95	-	V
		-	0, 15	15	14.95	-	14.95	-	14.95	-	V
LOW-level input voltage	V _{IL}	0.5, 4.5	-	5	-	1.5	-	1.5	-	1.5	V
		1, 9	-	10	-	3	-	3	-	3	V
		1.5, 13.5	-	15	-	4	-	4	-	4	V
HIGH-level input voltage	V _{IH}	0.5, 4.5	-	5	3.5	-	3.5	-	3.5	-	V
		1, 9	-	10	7	-	7	-	7	-	V
		1.5, 13.5	-	15	11	-	11	-	11	-	V
input leakage current	I _I	-	0, 15	15	-	±0.1	-	±1.0	-	±1.0	μA

AC Characteristics

 (T_{amb}=25°C, V_{SS}=0V, t_r, t_f=20ns, C_L=50pF, R_L=200KΩ, unless otherwise specified.)

Parameter	Symbol	Conditions	Min.	Typ.	Max.	Unit	
propagation delay time	t _{PHL} , t _{PLH}	see Figure 4	V _{DD} =5V	-	140	280	ns
			V _{DD} =10V	-	65	130	ns
			V _{DD} =15V	-	50	100	ns
transition time	t _{THL} , t _{TLH}	see Figure 4	V _{DD} =5V	-	100	200	ns
			V _{DD} =10V	-	50	100	ns
			V _{DD} =15V	-	40	80	ns
input capacitance	C _I	any input	-	5	7.5	pF	

Testing Circuit

AC Testing Circuit

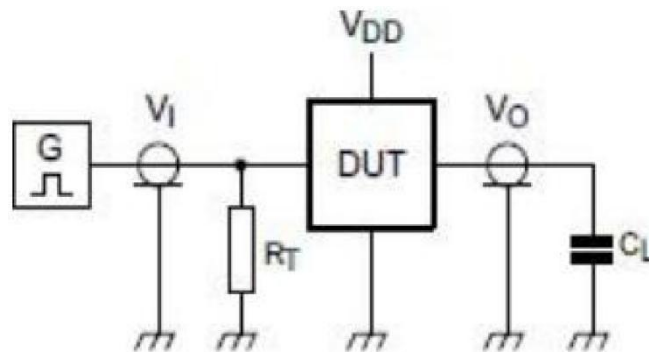

Figure 3. Test circuit for switching times

Definitions for test circuit:

DUT=Device Under Test

C_L =Load capacitance including jig and probe capacitance.

R_T =Termination resistance should be equal to the output impedance Z_o of the pulse generator.

AC Testing Waveforms

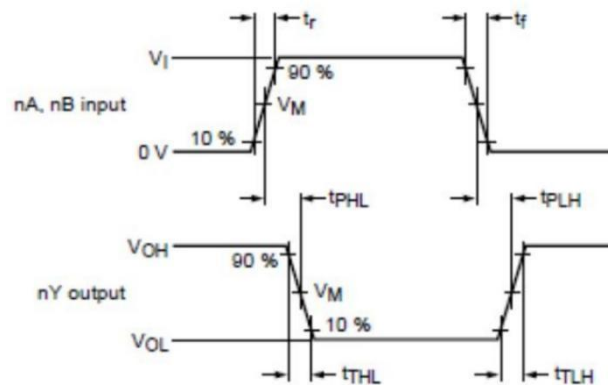

Figure 4. Input to output propagation delays and output transition times

Measurement Points

Supply voltage	Input	Output
V_{DD}	V_M	V_M
5V to 15V	$0.5 \times V_{DD}$	$0.5 \times V_{DD}$

Test Data

Supply voltage	Input		Load
V_{DD}	V_I	t_r, t_f	C_L
5V to 15V	V_{SS} or V_{DD}	$\leq 20\text{ns}$	50pF

Physical Dimensions

DIP-14

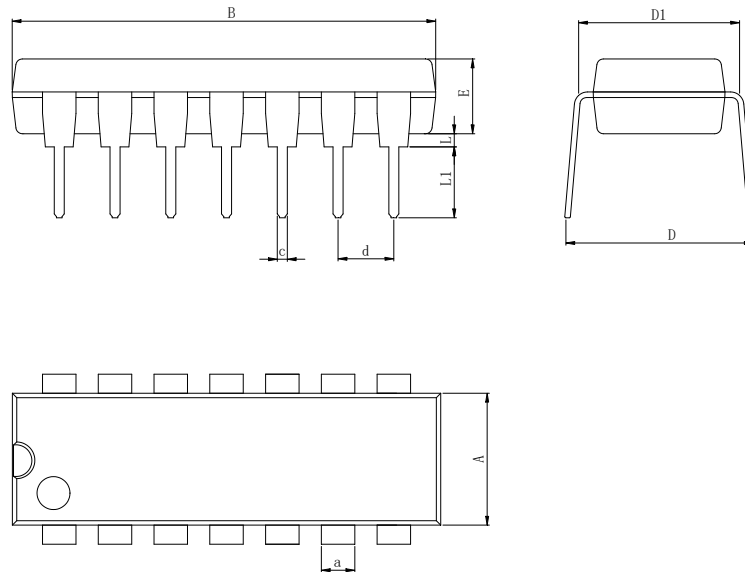

Dimensions In Millimeters(DIP-14)

Symbol:	A	B	D	D1	E	L	L1	a	c	d
Min:	6.10	18.94	8.10	7.42	3.10	0.50	3.00	1.50	0.40	2.54 BSC
Max:	6.68	19.56	10.9	7.82	3.55	0.70	3.60	1.55	0.50	

SOP-14

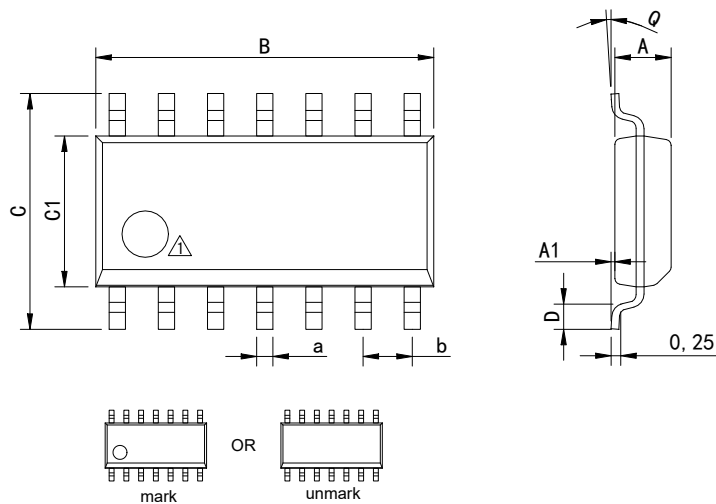

△ Package top mark may be in lower left corner or unmark

Dimensions In Millimeters(SOP-14)

Symbol:	A	A1	B	C	C1	D	Q	a	b
Min:	1.35	0.05	8.55	5.80	3.80	0.40	0°	0.35	1.27 BSC
Max:	1.55	0.20	8.75	6.20	4.00	0.80	8°	0.45	

Physical Dimensions

TSSOP-14

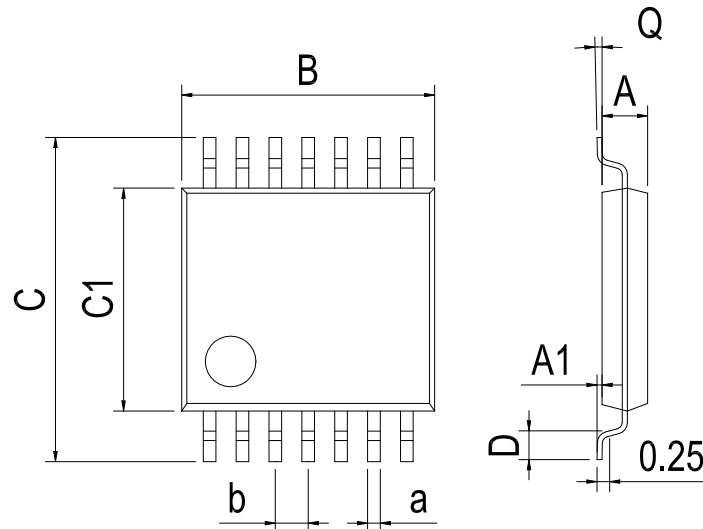

Dimensions In Millimeters(TSSOP-14)

Symbol:	A	A1	B	C	C1	D	Q	a	b
Min:	0.85	0.05	4.90	6.20	4.30	0.40	0°	0.20	0.65 BSC
Max:	0.95	0.20	5.10	6.60	4.50	0.80	8°	0.25	

QFN-16 3*3

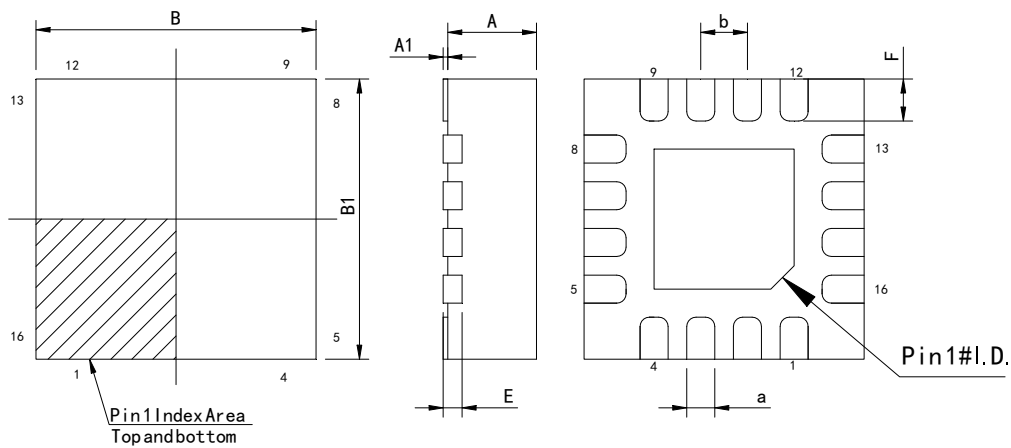

Dimensions In Millimeters(QFN-16 3*3)

Symbol:	A	A1	B	B1	E	F	a	b
Min:	0.85	0	2.90	2.90	0.15	0.25	0.18	0.50TYP
Max:	0.95	0.05	3.10	3.10	0.25	0.45	0.30	

Revision History

REVISION NUMBER	DATE	REVISION	PAGE
V1.0	2019-7	New	1-11
V1.1	2024-3	Document Reformatting	1-11
V1.2	2024-10	Update Lead Temperature	4
V1.3	2025-11	Update important statements、 Update SOP-14 Dimension drawing	8、 11
V1.4	2026-4	Add QFN-16 package model	1

IMPORTANT STATEMENT:

Huaguan Semiconductor reserves the right to change products and services offered without prior notice. Customers should obtain the latest relevant information before placing orders and verify that such information is current and complete. Huaguan Semiconductor assumes no responsibility or liability for altered documents.

Customers are responsible for complying with safety standards and implementing safety measures when using Huaguan Semiconductor products in system design and end-product manufacturing. You assume full responsibility for: selecting the appropriate Huaguan Semiconductor products for your application; designing, validating, and testing your application; and ensuring that your application complies with applicable standards and all other safety, security, or other requirements. This is to prevent potential risks that may lead to personal injury or property damage.

Huaguan Semiconductor products are not approved for use in life support, military, aerospace, or other high-risk applications. Huaguan products are neither intended nor warranted for use in such systems or equipment. Any failure or malfunction may lead to personal injury or severe property damage. Such applications are deemed "Unsafe Use." Unsafe Use includes, but is not limited to: surgical and medical equipment, nuclear energy control equipment, aircraft or spacecraft instruments, control or operation of vehicle power, braking, or safety systems, traffic signal instruments, all types of safety devices, and any other applications intended to support or sustain life. Huaguan Semiconductor shall not be liable for consequences resulting from Unsafe Use in these fields. Users must independently evaluate and assume all risks. Any issues, liabilities, or losses arising from the use of products beyond their approved applications shall be solely borne by the user. Users may not claim any compensation from Huaguan Semiconductor based on these terms. If any third party claims against Huaguan Semiconductor due to such Unsafe Use, the user shall compensate Huaguan Semiconductor for all resulting damages and liabilities.

Huaguan Semiconductor provides technical and reliability data (including datasheets), design resources (including reference designs), application or other design advice, web tools, safety information, and other resources for its semiconductor products. However, no guarantee is made that these resources are free from defects, and no express or implied warranties are provided. The use of testing and other quality control techniques is limited to Huaguan Semiconductor's quality assurance scope. Not all parameters of each device are tested.

Huaguan Semiconductor's documentation authorizes you to use these resources only for developing applications related to the products described herein. You are not granted rights to any other intellectual property of Huaguan Semiconductor or any third party. Any other reproduction or display of these resources is strictly prohibited. You shall fully indemnify Huaguan Semiconductor and its agents against any claims, damages, costs, losses, and liabilities arising from your use of these resources. Huaguan Semiconductor shall not be held responsible.