



LCD MODULE SPECIFICATION

Customer: _____

Module No.: TS070WSH02CQ-B8015C

Date: 2025-10-14

Version: 1.0

For Customer's Acceptance:

Approved by	Comment

Approved by	Checked by	Prepared by
Haitao.Zhou	Chenchen.Wang	Hongwei.Li

Table of Contents

Record of Revision	3
1 General Specifications	4
2 Pin Assignment	5
3 Absolute Maximum Ratings	7
4. Electrical Characteristics	8
5 Interface Description	9
6 Optical Characteristics	14
7 Environmental / Reliability Test	17
8 Mechanical Drawing	18
9 Precautions for Use of LCD Modules	19

1 General Specifications

No.	Item	Specification	Remark
1	LCD Size	7.0 inch	
2	Driver Element	a-Si TFT active matrix	
3	Resolution	1024 (RGB) ×600	
4	Display Mode	Normally Black	
5	Pixel Pitch	/	
6	Display Colors	16.7M	
7	Surface Treatment	Glare	
8	Color Arrangement	RGB-Stripe	
9	Interface	QSPI/SPI/8080	
10	Viewing Direction	ALL	
11	Gray Scale Inversion Direction	/	Note 1
12	Outline Dimension (mm)	164.90 (W) × 100.00 (H)	
13	Active Area (mm)	154.21 (W) × 85.92 (H)	
14	Touch Screen	With CTP	
15	Display Driver IC	TR230S	
16	Touch Driver IC	GT911	

Note 1: Viewing direction for best image quality is different from TFT definition. There is a 180° shift.

Note 2: RoHS compliant.

2 Pin Assignment

2.1 Pin assignment

Match connector: XF2M-4015-1A (OMRON) or equivalent.

N	Symbol	I/O	Description	Remark
1	GND	P	Ground	
2	GND	P	Ground	
3	VCC	P	POWER INPUT: 5VDC (4.5V to 5.5V)	
4	VCC	P	POWER INPUT: 5VDC (4.5V to 5.5V)	
5	GND	P	Ground	
6	DB0	I	8080-Data0,floating when not using	
7	DB1	I	8080:8080-Data1	
8	DB2	I	8080:8080-Data2	
9	DB3	I	8080:8080-Data3	
10	DB4	I	8080-Data4,floating when not using	
11	DB5	I	8080-Data5,floating when not using	
12	DB6	I	8080-Data6,floating when not using	
13	DB7	I	8080-Data7,floating when not using	
14	WR#	I	8080:WRITE strobe input SPI/DualSPI/QSPI:SPI-Clock(serial interface clock)	
15	GND	P	Ground	
16	RD#	I	8080:READ strobe input SPI:SPI-MOSI DualSPI:SPI-DATA0 QSPI:SPI-DATA0	
17	CS#	I/O	Chip selection:LOW active	
18	D/C#	I/O	DATA or COMMAND flag when choose 8080 or SPI-4WIRE interface: D/C#="H" is DATA or parameter D/C#="L" is COMMAND	
19	RESET#	I/O	TR230S Module_RESET and LCD-RESET: LOW active	
20	Testpad_TX	I/O	Reserved a testpad for upgrade default F/W	
21	Testpad_RX	I/O	Reserved a testpad for upgrade default F/W	
22	WAIT#	I/O	TE_ Frame synchronize	
23	IM0	I	Configurtation for interface selection	Note1
24	IM1	I	Configurtation for interface selection	Note1
25	QSPI-INT/8080-INT	I/O	Touch interrupt	Note2
26	DB8	I	8080-Data8,floating when not using	
27	DB9	I	8080-Data9 SPI:SPI-MISO DualSPI:SPI-DATA1 QSPI:QSPI-DATA1	

28	DB10	I	8080-Data10 QSPI:QSPI-DATA2	
29	DB11	I	8080-Data11 QSPI:QSPI-DATA3	
30	DB12	I	8080-Data12, floating when not using	
31	DB13	I	8080-Data13, floating when not using	
32	DB14	I	8080-Data14, floating when not using	
33	DB15	I	8080-Data15, floating when not using	
34	GND	P	Ground	
35	TP-GND	P	CTP-GND	
36	TP-RST	I	CTP-RESET	
37	TP-INT	I	CTP-Interruption	
38	TP-SCL	I	CTP-IIC_SCL	
39	TP-SDA	O	CTP-IIC_SDA	
40	TP-VCC	P	CTP-VCC(3.3V)	

I---Input, O---Output, P--- Power/Ground

Note1: IM[1:0] Configuration table

IM0	IM1	INTERFACE	Related Pins	Max. Clock
0	0	SPI-4WIRE	CS#, SCL, RD#, D/C#, DB9, WAIT#	100MHz
1	0	QSPI-4SDA	CS#, SCL, RD#, DB9, DB10, DB11, WAIT#	100MHz
0	1	8080-8bit	CS#, SCL, D0~D7, D/C#, RD#, WR#, WAIT#	50MHz
1	1	8080-16bit	CS#, SCL, D0~D15, D/C#, RD#, WR#, WAIT#	50MHz

Note2:

The PIN HOST does not need to be connected when the user drives the touch screen directly through the IIC. If the TR230 drives the touch screen, the user needs to detect the PIN to decide whether to read the touch event.



3 Absolute Maximum Ratings

Ta = 25°C

Item	Symbol	Min.	Max.	Unit	Remark
Power Voltage	VCC	-0.30	+5.5	V	
Operating Temperature	Top	-20.0	70.0	°C	
Storage Temperature	T _{st}	-30.0	80.0	°C	
Operating and Storage Humidity	H _{stg}	10%	90%	%(RH)	

4 Electrical Characteristics

4.1 Recommended Operating Condition

VCC=5V, GND=0V, Ta = 25°C

Item	Symbol	Min.	Typ.	Max.	Unit	Remark
Power supply Voltage	VCC	4.5	5	5.5	V	
Input Signal Voltage	Low Level V _{IL}	-0.3	-	0.3 x 3.3	V	
	High Level V _{IH}	0.7 x 3.3	-	3.3 + 0.3	V	
Power supply Voltage	I _{VCC}	-	520		mA	VCC=5V, color bar pattern

4.2 Backlight Unit Driving Condition

Item	Symbol	Min.	Typ.	Max.	Unit	Remark
Forward Current	I _F	-	180	200	mA	27LEDs (3 LED Serial, 9 LED Parallel)Note5
Forward Current Voltage	V _F	-	9.6	-	V	
Backlight Power Consumption	W _{BL}	-	1728	-	mW	
Operating Life Time	--	20000	--	--	hrs	Note 2, Note 3

Note1: The LED driving condition is defined for each module (3 LED Serial, 9 LED Parallel).

Note2: When LCM is operated, the stable forward current should be inputted. And forward voltage is for reference only.

Note3: Optical performance should be evaluated at Ta=25°C When LED is driven at high current, high ambient temperature & humidity condition. The life time of LED will be reduced. Operating life means brightness goes down to 50% initial brightness. Typical operating life time is estimated data.

Note4: The LED driving condition is defined for each LED module.

Note5: The product has already integrated the backlight driving circuit.

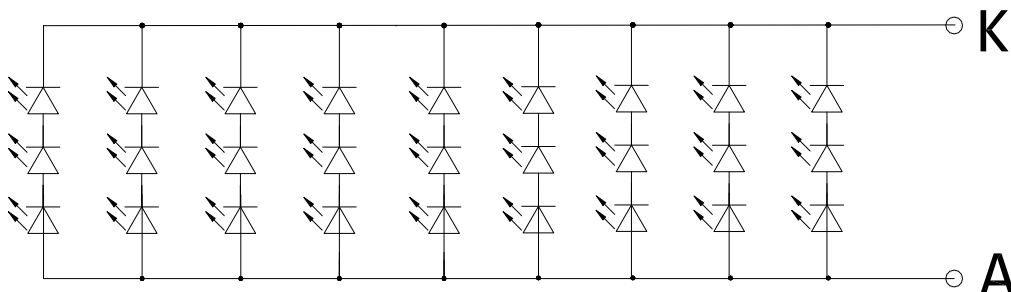

5 Interface Description

If there is no special indication, TR230S works on Mode 0, That means data transmission occurs during rising edge of the clock.

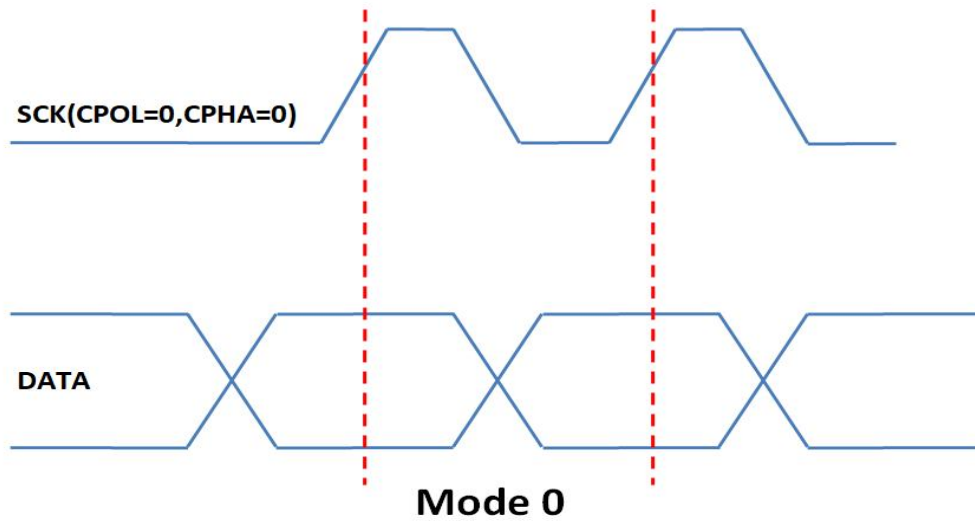

5.1 PIN DESCRIPTION

5.1.1 SPI INTERFACE (SPI-4WIRE, QSPI-4SDA)

PIN NAME	Description
CS#	Chip selection: LOW active
SCL	Serial Interface Clock
RD#	SPI: MOSI QSPI: QSPI-DATA0
DB9	SPI: MISO QSPI: QSPI-DATA1
DB10	QSPI: QSPI-DATA2
DB11	QSPI: QSPI-DATA3
D/C#	DATA or COMMAND flag, 0:COMMAND 1:DATA
WAIT#	WAIT# STATUS flag, 0: Sending Command Not Allowed 1: Sending Command Allowed

5.1.2 8080 PIN DESCRIPTION

PIN NAME	Description
CS#	Chip selection: LOW active
WR	WRITE strobe input, rising edge effective
DB0~DB15	DATA BUS
D/C#	DATA or COMMAND flag, 0:COMMAND 1:DATA
WAIT#	BUSY STATUS flag, 0: Sending Command Not Allowed 1: Sending Command Allowed

5.2 INTERFACE TIMING

• SPI-4WIRE

Timing for sending command and data:

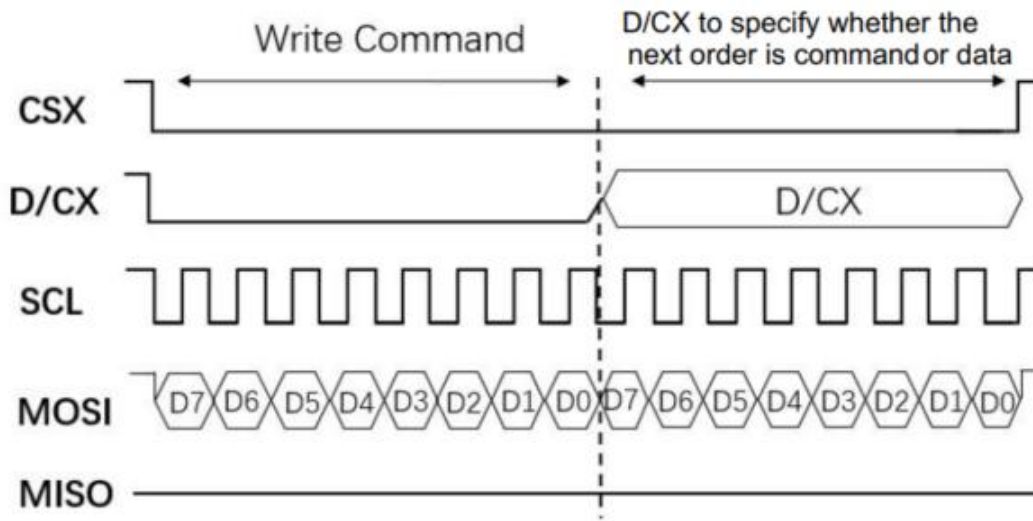

Display data writing format:

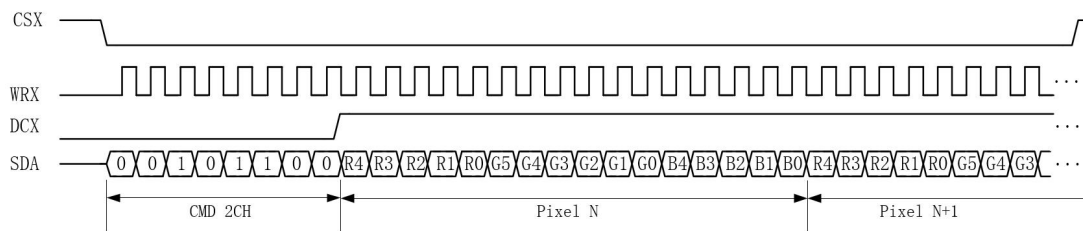

• QSPI-4SDA

Timing for sending command:
 (CODE1=0x02, CODE2=CODE3=0x00)

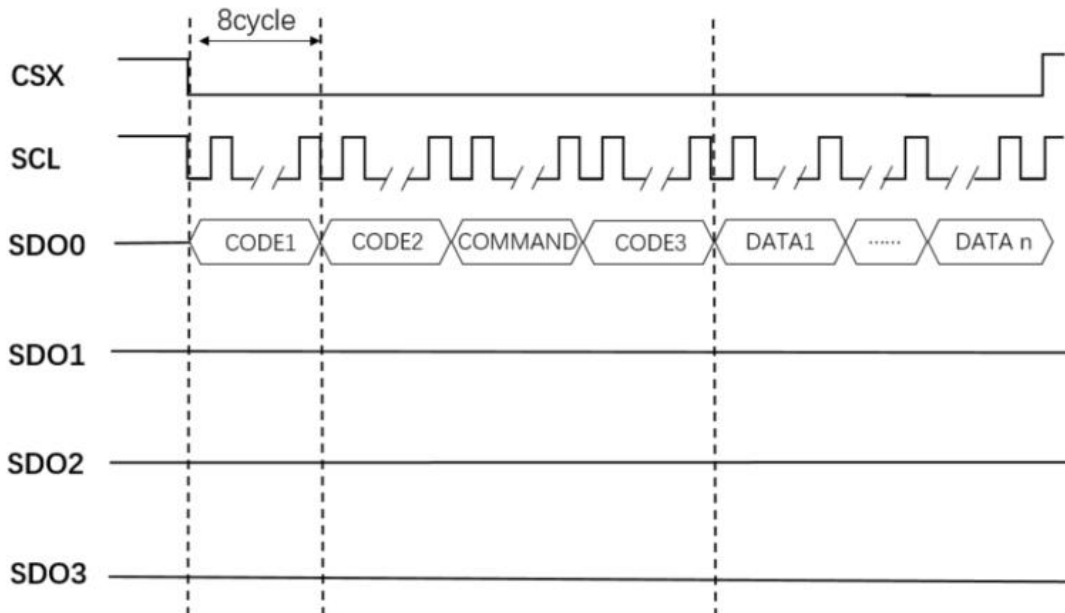

Display data writing format:
 (CODE1=0x12, CODE2=CODE3=0x00 COMMAND = 0x2C)

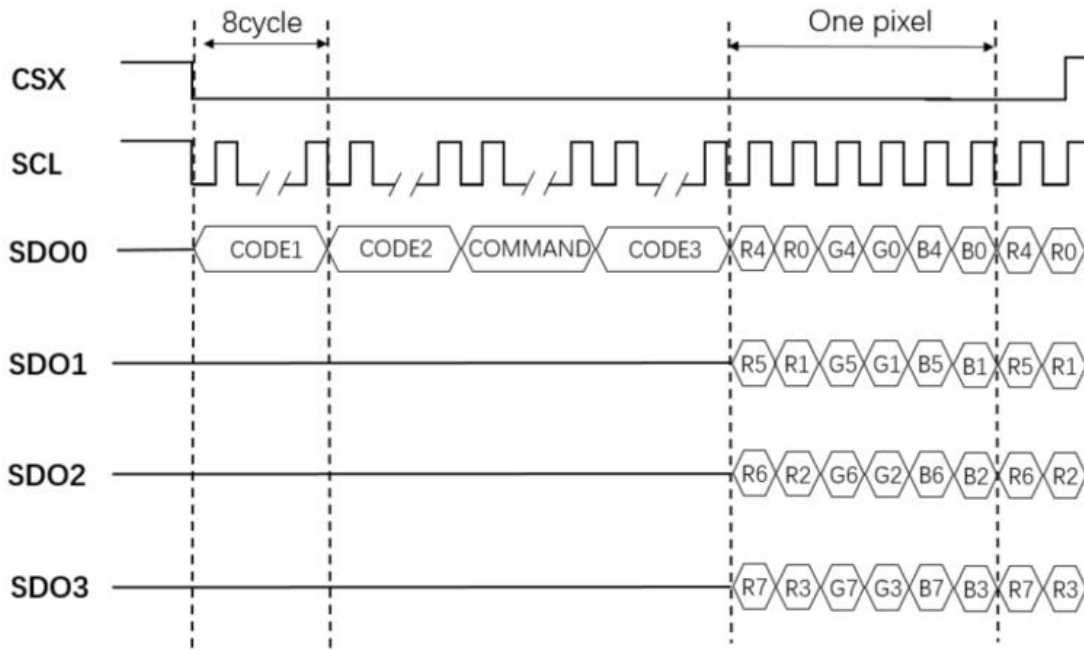

- 8080(8080-8/16)

Timing for sending command and data:

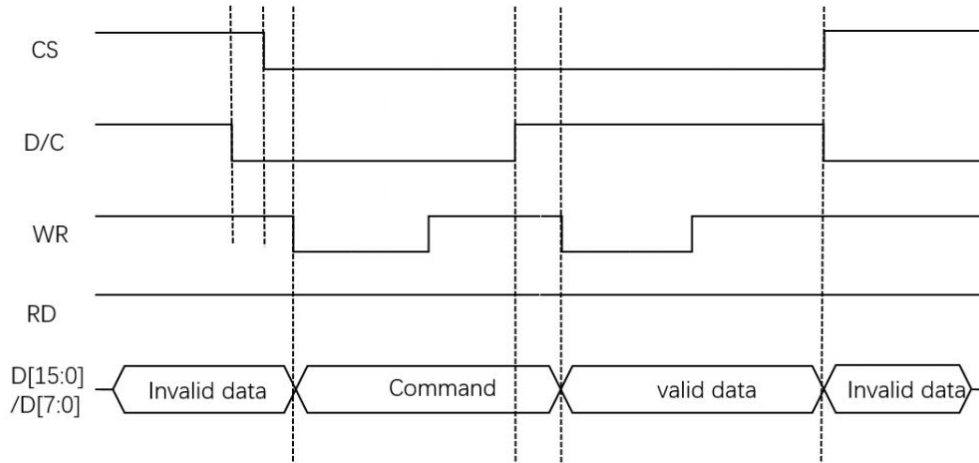

Display data writing format (8080-8B):

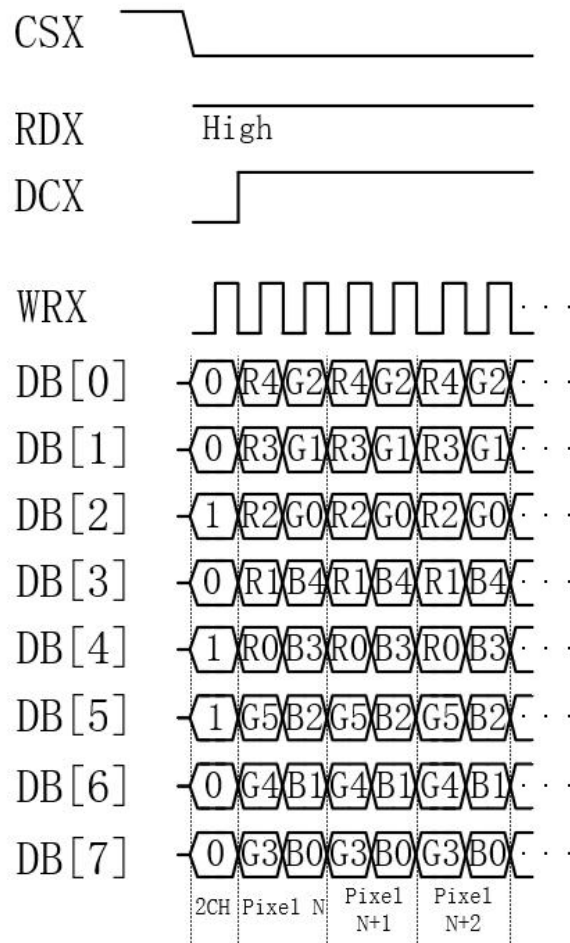

Display data writing format(8080-16B)

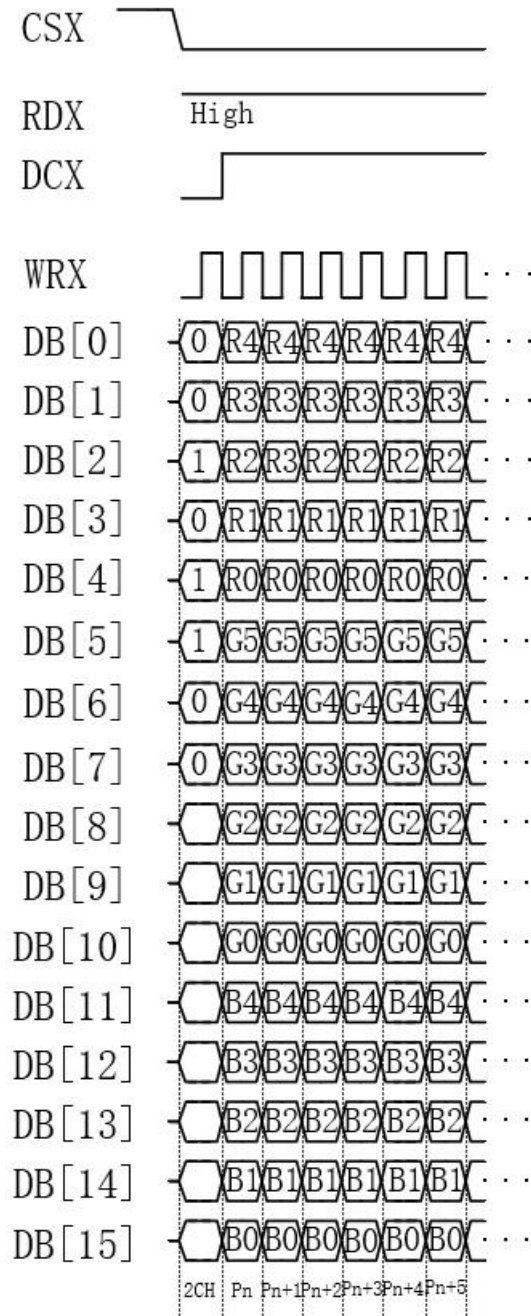

6 Optical Characteristics

Ta=25°C

Item	Symbol	Condition	Min.	Typ.	Max.	Unit	Remark
View Angles	θ_T	$CR \geq 10$	-	80	-	Degree	Note 2
	θ_B		-	80	-		
	θ_L		-	80	-		
	θ_R		-	80	-		
Contrast Ratio	CR	$\theta=0^\circ$	700	800	-		Note1 Note3
Response Time	T_{ON}	25°C	--	30	40	ms	Note1 Note4
	T_{OFF}						
Uniformity	U		70	80	-	%	Note1 Note6
NTSC			-	70	-	%	Note 5
Luminance	L		360	450	-	cd/m ²	Note1 Note7

Test Conditions:

1. $I_F=180\text{ mA}$, $V_F=9.6\text{ V}$ and the ambient temperature is $25\pm 2^\circ\text{C}$. humidity is $65\pm 7\%$
2. The test systems refer to Note 1 and Note 2.

Note 1: Definition of optical measurement system.

Properties are measured at the center point of the LCD screen. All input terminals LCD panel must be ground when measuring the center area of the panel.

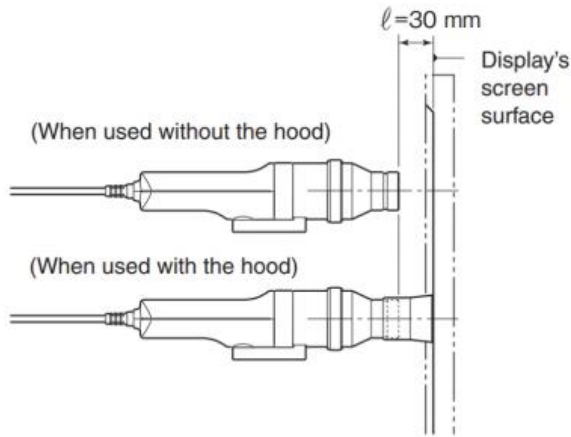

Item	Photo detector	Field
Contrast Ratio	CA210 or similar equipment	1°
Luminance		
Chromaticity		
Lum Uniformity		
Response Time	BM-7A	2°

Note 2: Definition of viewing angle range and measurement system.

Viewing angle is measured at the center point of the LCD by CONOSCOPE(ergo-80)。

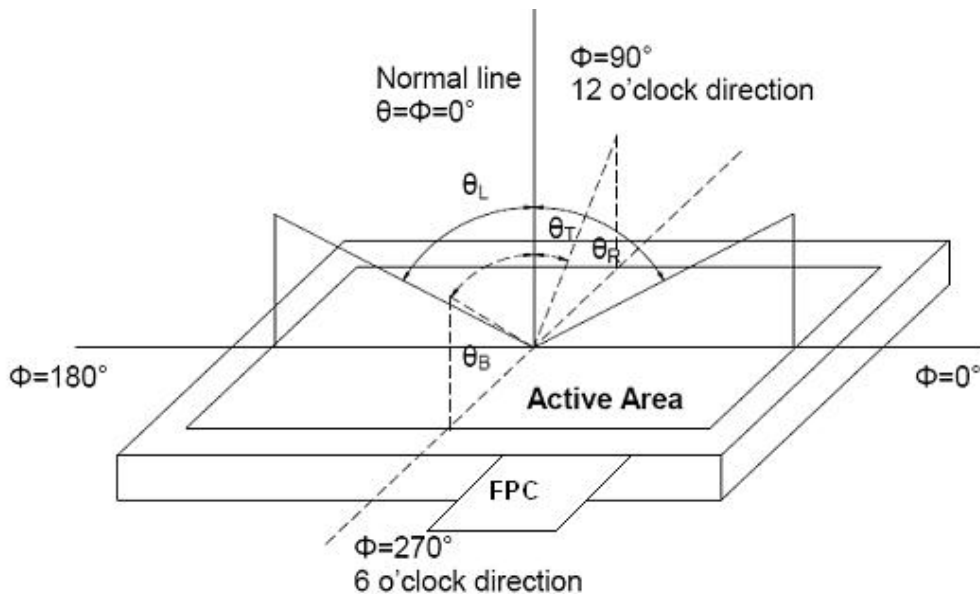

Note 3: Definition of contrast ratio

$$\text{Contrast ratio (CR)} = \frac{\text{Luminance measured when LCD is on the "White" state}}{\text{Luminance measured when LCD is on the "Black" state}}$$

“White state “: The state is that the LCD should drive by V_{white} .

“Black state“: The state is that the LCD should drive by V_{black} .

V_{white} : To be determined V_{black} : To be determined.

Note 4: Definition of response time

The response time is defined as the LCD optical switching time interval between “White” state and “Black” state. Rise time (T_{ON}) is the time between photo detector output intensity changed from 90% to 10%. And fall time (T_{OFF}) is the time between photo detector output intensity changed from 10% to 90%.

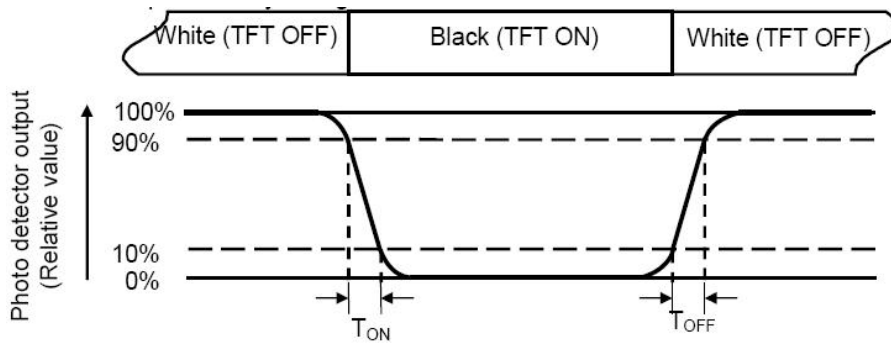

Note 5: Definition of color chromaticity (CIE1931)

Color coordinates measured at center point of LCD.

Note 6: Definition of luminance uniformity

Active area is divided into 9 measuring areas (Refer Fig. 2). Every measuring point is placed at the center of each measuring area.

$$\text{Luminance Uniformity (U)} = L_{\min} / L_{\max}$$

L-----Active area length W----- Active area width

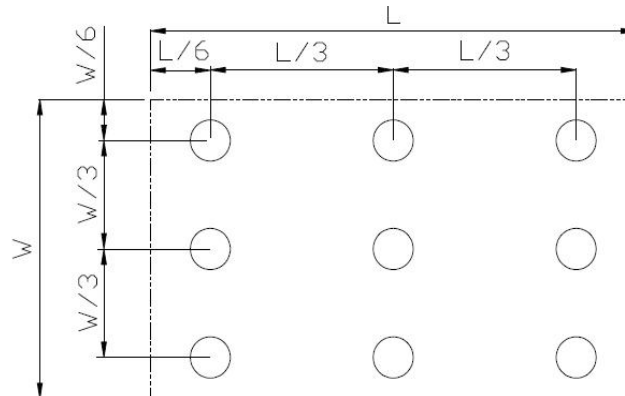

L_{\max} : The measured Maximum luminance of all measurement position.

L_{\min} : The measured Minimum luminance of all measurement position.

Note 7: Definition of luminance:

Measure the luminance of white state at center point.

7 Environmental / Reliability Test

No	Test Item	Condition	Remarks
1	High Temperature Operation	Ts = +70°C, 240 hours	IEC60068-2-1 GB2423.2
2	Low Temperature Operation	Ta = -20°C, 240 hours	IEC60068-2-1 GB2423.1
3	High Temperature Storage	Ta = +80°C, 240 hours	IEC60068-2-1 GB2423.2
4	Low Temperature Storage	Ta = -30°C, 240 hours	IEC60068-2-1 GB2423.1
5	Storage at High Temperature and Humidity	Ta = +60°C, 90% RH max, 240 hours	IEC60068-2-78 GB/T2423.3
6	Thermal Shock (non-operating)	-30°C 30 min ~ +70°C 30 min, Change time: 0.5 hour ← 5 min → 0.5 hour. 10 Cycle	Start with cold temperature, End with high temperature,
7	ESD	C=150pF, R=330Ω, 5point/panel Air: ±8Kv, 5times; Contact: ±4Kv, 5times (Environment: 15°C~35°C, 30%~60%. 86Kpa~106Kpa)	IEC61000-4-2 GB/T17626.2

Note1: Ts is the temperature of panel's surface.

Note2: Ta is the ambient temperature of samples.

8 Mechanical Drawing

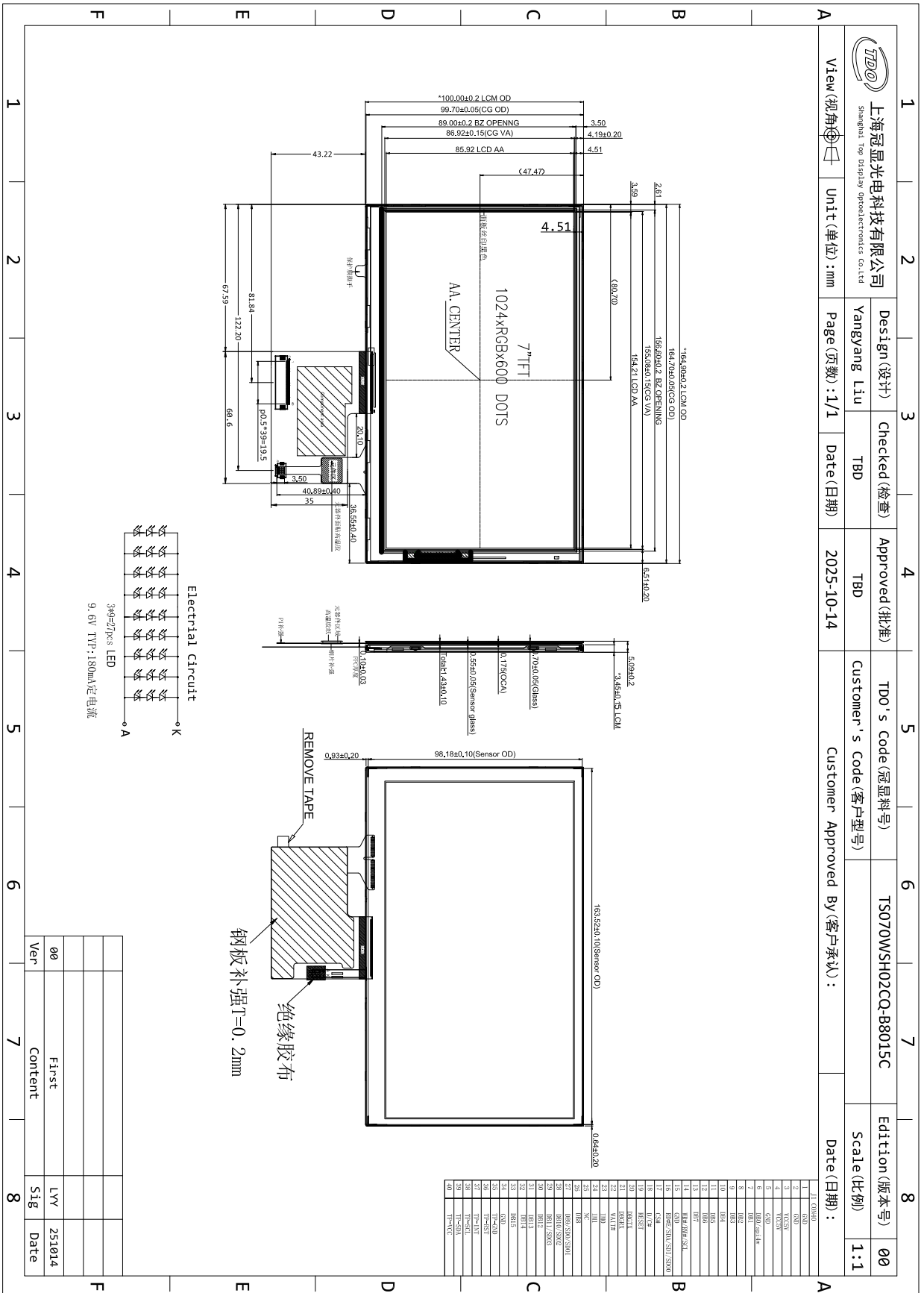

9 Precautions for Use of LCD Modules

Handling Precautions

9.1.1 The display panel is made of glass. Do not subject it to a mechanical shock by dropping it from a high place, etc.

9.1.2 If the display panel is damaged and the liquid crystal substance inside it leaks out, be sure not to get any in your mouth, if the substance comes into contact with your skin or clothes, promptly wash it off using soap and water.

9.1.3 Do not apply excessive force to the display surface or the adjoining areas since this may cause the color tone to vary.

9.1.4 The polarizer covering the display surface of the LCD module is soft and easily scratched. Handle this polarizer carefully.

9.1.5 If the display surface is contaminated, breathe on the surface and gently wipe it with a soft dry cloth. If still not completely clear, moisten cloth with one of the following solvents:

- Isopropyl alcohol
- Ethyl alcohol

Solvents other than those mentioned above may damage the polarizer. Especially, do not use the following:

- Water
- Ketone
- Aromatic solvents

9.1.6 Do not attempt to disassemble the LCD Module.

9.1.7 If the logic circuit power is off, do not apply the input signals.

9.1.8 To prevent destruction of the elements by static electricity, be careful to maintain an optimum work environment.

9.1.8.1 Be sure to ground the body when handling the LCD Modules.

9.1.8.2 Tools required for assembly, such as soldering irons, must be properly ground.

9.1.8.3 To reduce the amount of static electricity generated, do not conduct assembly and other work under dry conditions.

9.1.8.4 The LCD Module is coated with a film to protect the display surface. Be care when peeling off this protective film since static electricity may be generated.

Storage Precautions

9.2.1 When storing the LCD modules, avoid exposure to direct sunlight or to the light of fluorescent lamps.

9.2.2 The LCD modules should be stored under the storage temperature range. If the LCD modules will be stored for a long time, the recommend condition is: Temperature : 0°C ~ 40°C Relatively humidity: ≤80%

9.2.3 The LCD modules should be stored in the room without acid, alkali and harmful gas.

Transportation Precautions

9.3.1 The LCD modules should be no falling and violent shocking during transportation, and also should avoid excessive press, water, damp and sunshine.