



# SuperTan® Wet Tantalum Capacitors With Hermetic Seal, Extended Range, Improved Vibration Capability



## LINKS TO ADDITIONAL RESOURCES



## PERFORMANCE CHARACTERISTICS

Refer to: Typical Performance Characteristics

**Operating Temperature:** -55 °C to +85 °C  
(to +125 °C with voltage derating)

**Capacitance Tolerance:** ± 10 %, ± 20 % standard

**DC Leakage Current (DCL Max.):** at +25 °C and above: leakage current shall not exceed the values listed in the Standard Ratings table.

## FEATURES

- Enhanced performance, high reliability design
- Terminations: axial, standard tin / lead (SnPb), 100 % tin available
- Model STH tantalum-case electrolytic capacitors provide all the advantages of Vishay's SuperTan® extended series devices, while offering **improved vibration capability**
- Increased thermal shock capability of up to 300 cycles
- Designed for the avionics and aerospace applications
- Material categorization: for definitions of compliance please see [www.vishay.com/doc?99912](http://www.vishay.com/doc?99912)



## Note

\* This datasheet provides information about parts that are RoHS-compliant and / or parts that are non RoHS-compliant. For example, parts with lead (Pb) terminations are not RoHS-compliant. Please see the information / tables in this datasheet for details

ORDERING INFORMATION								
STH	D	128	M	075	E (1)	S (2)	H	S
MODEL	CASE CODE	CAPACITANCE	CAPACITANCE TOLERANCE	DC VOLTAGE RATING AT +85 °C	TERMINATION AND PACKAGING	INSULATING SLEEVE	RELIABILITY / SHOCK / VIBRATION LEVEL	ESR
		This is expressed in picofarads. The first two digits are the significant figures. The third is the number of zeros to follow	K = ± 10 % M = ± 20 %	This is expressed in volts. To complete the three-digit block, zeros precede the voltage rating	E = axial, tin / lead, bulk C = axial, 100 % tin, bulk J = SMD, outside bend, tin / lead K = SMD, outside bend, 100 % tin L = SMD, inside bend, tin / lead M = SMD, inside bend, 100 % tin	S = sleeved U = unsleeved	H = high	S = standard L = low

## Notes

- Packaging: the use of formed plastic trays for packing bulk components is standard
- (1) J, K, L, M are available in T4. For all other case sizes, check with marketing
- (2) Sleeve on J, K, L, M terminations shall be Kapton only

AXIAL PRODUCT DIMENSIONS in inches [millimeters]							
<p>0.0253 ± 0.002 [0.64 ± 0.05] dia. (no. 22 AWG) tinned nickel leads solderable and weldable</p>							
CASE CODE		D	L <sub>1</sub>	L <sub>2</sub> (max.)	E	WEIGHT (g) (max.)	
TYPE	STH	ST					
A		T1	0.188 ± 0.016 [4.78 ± 0.41]	0.453 + 0.031 / - 0.016 [11.51 + 0.79 / - 0.41]	0.734 [18.64]	1.500 ± 0.250 [38.10 ± 6.35]	2.6
B		T2	0.281 ± 0.016 [7.14 ± 0.41]	0.641 + 0.031 / - 0.016 [16.28 + 0.79 / - 0.41]	0.922 [23.42]	2.250 ± 0.250 [57.15 ± 6.35]	6.2
C		T3	0.375 ± 0.016 [9.52 ± 0.41]	0.766 + 0.031 / - 0.016 [19.46 + 0.79 / - 0.41]	1.047 [26.59]	2.250 ± 0.250 [57.15 ± 6.35]	11.6
D		T4	0.375 ± 0.016 [9.52 ± 0.41]	1.062 + 0.031 / - 0.016 [26.97 + 0.79 / - 0.41]	1.343 [34.11]	2.250 ± 0.250 [57.15 ± 6.35]	17.7

## Note

- For insulated parts, add 0.015" [0.38 mm] to the diameter. The insulation shall lap over the ends of the capacitor body



**SMD PRODUCT DIMENSIONS** in inches [millimeters]

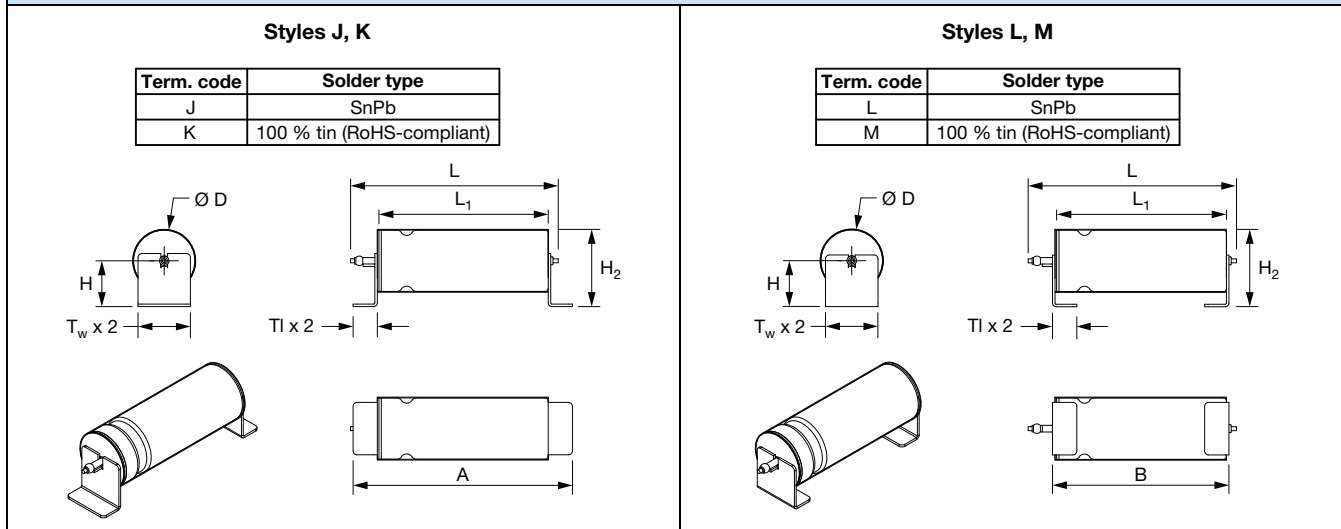

Term. code	Solder type
J	SnPb
K	100 % tin (RoHS-compliant)

Term. code	Solder type
L	SnPb
M	100 % tin (RoHS-compliant)

CASE CODE		A	B	TI	H	T <sub>w</sub> ± 0.005	H <sub>2</sub>	L	L <sub>1</sub>	D
TYPE	STH	(max.)	(max.)	(max.)	(max.)		(max.)	(max.)		(max.)
A	T1	0.773 [19.6]	0.513 [13.0]	0.157 [4.0]	0.177 [4.5]	0.158 [4.0]	0.296 [7.5]	0.705 [17.9]	0.469 + 0.031 / - 0.016 [11.91 + 0.79 / - 0.41]	0.228 [5.8]
D	T4	1.432 [36.4]	1.140 [29.0]	0.157 [4.0]	0.295 [7.5]	0.331 [8.4]	0.492 [12.5]	1.343 [34.1]	1.062 + 0.031 / - 0.016 [26.97 + 0.79 / - 0.41]	0.397 [10.1]

**Note**

- Use appropriate adhesive between capacitor body and the board for improved mechanical strength

**RATINGS AND CASE CODES**

µF	60 V	75 V	100 V	125 V
47	A			
470				D
560				D <sup>(1)</sup>
750			D	
880			D	
1200		D		
1500		D <sup>(1)</sup>		

**Note**

- <sup>(1)</sup> Preliminary rating. Contact marketing for availability

**STANDARD RATINGS**

CAPACITANCE AT +25 °C 120 Hz (µF)	CASE CODE	PART NUMBER	MAX. ESR AT +25 °C 120 Hz (Ω)	MAX. IMP. AT -55 °C 120 Hz (Ω)	MAX. DCL (µA) AT +25 °C	MAX. CAPACITANCE CHANGE AT (%) -55 °C +85 °C +125 °C	AC RIPPLE +85 °C 40 kHz (mA <sub>RMS</sub> )	THERMAL SHOCK NUMBER OF CYCLES
<b>60 V<sub>DC</sub> AT 85 °C, 40 V<sub>DC</sub> AT 125 °C</b>								
47	A	STHA476(1)060(2)(3)HS	2	44	1	5	-25 8 12	1050 300
<b>75 V<sub>DC</sub> AT 85 °C, 50 V<sub>DC</sub> AT 125 °C</b>								
1200	D	STHD128(1)075(2)(3)HS	0.50	8.00	30	300	-70 25 30	4000 300
1500	D <sup>(1)</sup>	STHD158(1)075(2)(3)HS	0.50	8.00	30	300	-75 25 30	4000 300
<b>100 V<sub>DC</sub> AT 85 °C, 65 V<sub>DC</sub> AT 125 °C</b>								
750	D	STHD757(1)100(2)(3)HS	0.70	10.00	30	300	-75 30 30	4000 300
880	D	STHD887(1)100(2)(3)HS	0.60	10.00	30	300	-75 30 30	4000 300
<b>125 V<sub>DC</sub> AT 85 °C, 85 V<sub>DC</sub> AT 125 °C</b>								
470	D	STHD477(1)125(2)(3)HS	1.00	18.00	30	300	-70 30 30	3500 300
560	D <sup>(1)</sup>	STHD567(1)125(2)(3)HS	0.70	20.00	35	350	-75 30 30	3500 300

**Notes**

- Part number definitions:
  - (1) Capacitance tolerance: K, M
  - (2) Termination / packaging: C = 100 % tin, bulk; E = standard, tin / lead, bulk; J = SMD, outside bend, tin / lead; K = SMD, outside bend, 100 % tin; L = SMD, inside bend, tin / lead; M = SMD, inside bend, 100 % tin
  - (3) Insulating sleeve: S = sleeved; U = unsleeved
- (1) Rating in development, contact factory for availability



## TYPICAL PERFORMANCE CHARACTERISTICS OF STH CAPACITORS

ELECTRICAL CHARACTERISTICS	
ITEM	PERFORMANCE CHARACTERISTICS
Operating temperature range	-55 °C to +85 °C (to +125 °C with voltage derating)
Capacitor tolerance	± 20 %, ± 10 % at 120 Hz, at +25 °C
Capacitor change by temperature	Limit per Standard Ratings table
ESR	Limit per Standard Ratings table, at +25 °C, 120 Hz
Impedance	Limit per Standard Ratings table, at -55 °C, 120 Hz
DCL (leakage current)	Limit per Standard Ratings table
AC ripple current	Limit per Standard Ratings table, at +85 °C and 40 kHz
Reverse voltage	There shall be no continuous reverse voltage. Transient reverse voltage surges are acceptable under the following conditions: a) The peak reverse voltage is equal to or less than 1.5 V and the product of the peak current times the duration of the reverse transient is 0.05 A or less b) The repetition rate of the reverse voltage surges is less than 10 Hz
Surge voltage	Surge voltage shall be in accordance with MIL-PRF-39006. The DC rated surge voltage is the maximum voltage to which the capacitors can be subjected under any conditions including transients and peak ripple at the highest line voltage. The DC surge voltage is 115 % of rated DC voltage, except the applicable surge voltage for 125 V ratings and ratings above 1000 µF is rated DC voltage. After the test, the capacitors shall meet the following requirements: a) DC leakage shall not exceed the specified value in catalog b) Capacitance change shall be within +5 %, -20 % (-35 % for capacitance above 1000 µF) of initial measured value

PERFORMANCE CHARACTERISTICS	
ITEM	PERFORMANCE CHARACTERISTICS
Life testing	Capacitors shall be capable of withstanding a 2000 h life test at a temperature +85 °C at rated voltage, or a 2000 h life test at 125 °C test at derated voltage. After the test, the capacitors shall meet the following requirements: a) DC leakage at 85 °C and 125 °C shall not exceed 125 % of the specified value b) DC leakage at 25 °C shall not exceed the specified value c) Capacitance shall be within +10 %, -20 % of initial value d) ESR shall not exceed 200 % of the specified value

ENVIRONMENTAL CHARACTERISTICS		
ITEM	CONDITION	COMMENTS
Seal	MIL-PRF-39006	When the capacitors are tested as specified in MIL-PRF-39006, there shall be no evidence of leakage.
Moisture resistance	MIL-PRF-39006	Moisture resistance shall be in accordance with MIL-PRF-39006. Number of cycles: 10 continuous cycles
Barometric pressure (reduced)	MIL-STD-202, method 105, condition E	Altitude 150 000 feet



<b>MECHANICAL CHARACTERISTICS</b>		
<b>ITEM</b>	<b>CONDITION</b>	<b>COMMENTS</b>
Shock (specified pulse)	MIL-STD-202, method 213, condition D (500 g)	The capacitors shall meet the requirements of MIL-PRF-39006.
Vibration, high frequency	MIL-STD-202, method 204, condition H (80 g peak)	The capacitors shall meet the requirements of MIL-PRF-39006.
Random vibration	MIL-STD-202, method 214, condition II-K (53.79 g RMS)	The capacitors shall meet the requirements of MIL-PRF-39006.
Thermal shock	MIL-STD-202, method 107, condition A	Thermal shock shall be in accordance with MIL-PRF-39006. Maximum number of cycles is according to Standard Ratings table.
Solderability	MIL-STD-202, method 208, ANSI/J-STD-002, condition A	Solderability shall be in accordance with MIL-PRF-39006.
Terminal strength	MIL-STD-202, method 211	Terminal strength shall be in accordance with MIL-PRF-39006.
Resistance to solder heat	MIL-STD-202, method 210, condition C	The capacitors shall meet the requirements of MIL-PRF-39006.
Terminals	MIL-STD-1276	Terminals shall be as specified in MIL-STD-1276. The length and diameter of the terminals shall be as specified in Dimensions table. All terminals shall be permanently secured internally and externally, as applicable. All external joints shall be welded.
Marking	MIL-STD-1285	Marking of capacitors conforms to method I of MIL-STD-1285 and include capacitance (in $\mu\text{F}$ ), capacitance tolerance letter, rated voltage, date code, lot symbol, and Vishay trademark.

<b>SELECTOR GUIDES</b>	
Tantalum Selector Guide	<a href="http://www.vishay.com/doc?49054">www.vishay.com/doc?49054</a>
Parameter Comparison Guide	<a href="http://www.vishay.com/doc?42088">www.vishay.com/doc?42088</a>



## Disclaimer

ALL PRODUCT, PRODUCT SPECIFICATIONS AND DATA ARE SUBJECT TO CHANGE WITHOUT NOTICE TO IMPROVE RELIABILITY, FUNCTION OR DESIGN OR OTHERWISE.

Vishay Intertechnology, Inc., its affiliates, agents, and employees, and all persons acting on its or their behalf (collectively, "Vishay"), disclaim any and all liability for any errors, inaccuracies or incompleteness contained in any datasheet or in any other disclosure relating to any product.

Vishay makes no warranty, representation or guarantee regarding the suitability of the products for any particular purpose or the continuing production of any product. To the maximum extent permitted by applicable law, Vishay disclaims (i) any and all liability arising out of the application or use of any product, (ii) any and all liability, including without limitation special, consequential or incidental damages, and (iii) any and all implied warranties, including warranties of fitness for particular purpose, non-infringement and merchantability.

Statements regarding the suitability of products for certain types of applications are based on Vishay's knowledge of typical requirements that are often placed on Vishay products in generic applications. Such statements are not binding statements about the suitability of products for a particular application. It is the customer's responsibility to validate that a particular product with the properties described in the product specification is suitable for use in a particular application. Parameters provided in datasheets and / or specifications may vary in different applications and performance may vary over time. All operating parameters, including typical parameters, must be validated for each customer application by the customer's technical experts. Product specifications do not expand or otherwise modify Vishay's terms and conditions of purchase, including but not limited to the warranty expressed therein.

Hyperlinks included in this datasheet may direct users to third-party websites. These links are provided as a convenience and for informational purposes only. Inclusion of these hyperlinks does not constitute an endorsement or an approval by Vishay of any of the products, services or opinions of the corporation, organization or individual associated with the third-party website. Vishay disclaims any and all liability and bears no responsibility for the accuracy, legality or content of the third-party website or for that of subsequent links.

Except as expressly indicated in writing, Vishay products are not designed for use in medical, life-saving, or life-sustaining applications or for any other application in which the failure of the Vishay product could result in personal injury or death. Customers using or selling Vishay products not expressly indicated for use in such applications do so at their own risk. Please contact authorized Vishay personnel to obtain written terms and conditions regarding products designed for such applications.

No license, express or implied, by estoppel or otherwise, to any intellectual property rights is granted by this document or by any conduct of Vishay. Product names and markings noted herein may be trademarks of their respective owners.