

修订	标记	修改摘要	签名	日期
REV	NO	NEW DWG		2016-03-12

- NOTES:
- MATERIAL:
    - MOLDING: LCP/PA9T UL94 V-0
    - CONTACT: COPPER ALLOY.
    - GOLD PLATED Min ON CONTACT AREA, 100u"
    - Min TIN (LEAD FREE) ON SOLDER AREA,
    - SHELL: SUS304-H,T=0.30±0.03mm
    - 50u" NICKEL PLATING OVER ALL.
    - SHILD: SUS301-H,T=0.15±0.03mm
  - MECHANICAL:
    - INSERTION: 5~20N.
    - EXTRACTION: 8~20N AFTER TEST.
    - DURABILITY: 10000 CYCLES
  - ELECTRICAL:
    - CURRENT: 5A FOR VBUS;
    - 1.25A FOR GND PIN.
    - 0.25A FOR OTHER.
    - VOLTAGE: 20 V MAX
    - WITHSTANDING VOLTAGE: 100V AC R.M.S.
    - CONTACT RESISTANCE: 40mΩ MAX.
    - INSULATION RESISTANCE: 100MΩ MIN.
  - ENVIRONMENTAL
    - TEMPERATURE RANGE -25°C ~ +85°C

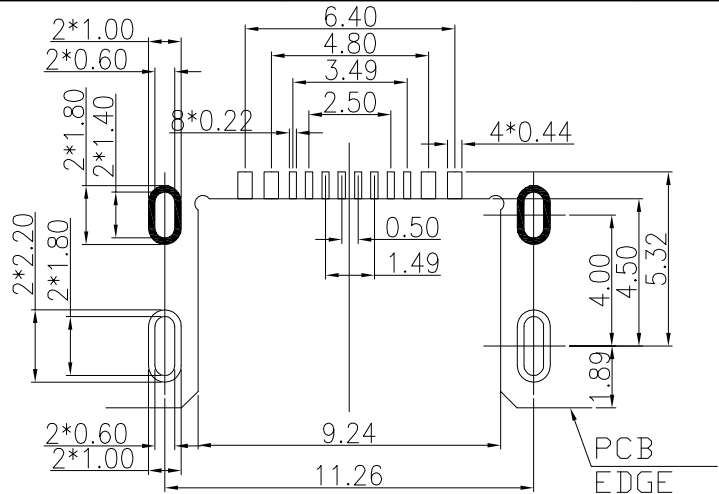

RECOMMEND P.C.B LAYOUT (COMPONENT SIDE)  
TOLERANCE FOR PCB LAYOUT 1.0 ± 0.05

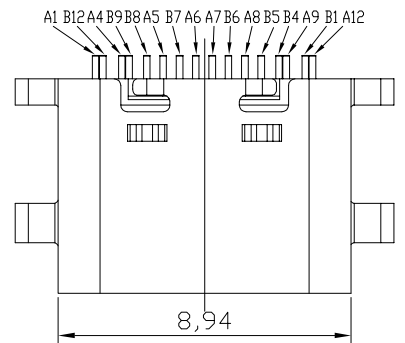
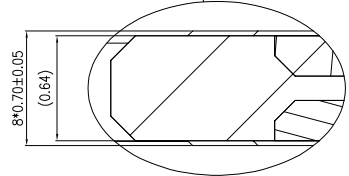
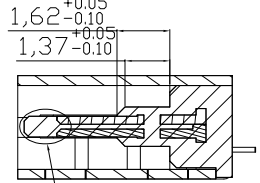
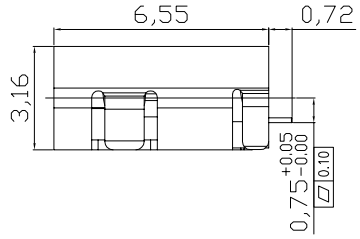
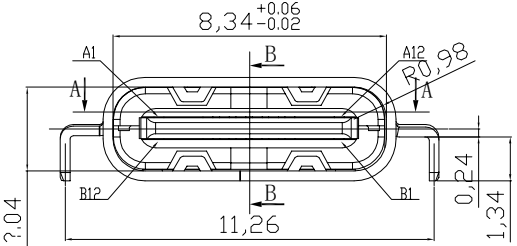

SC:5:1

剖面 B-B

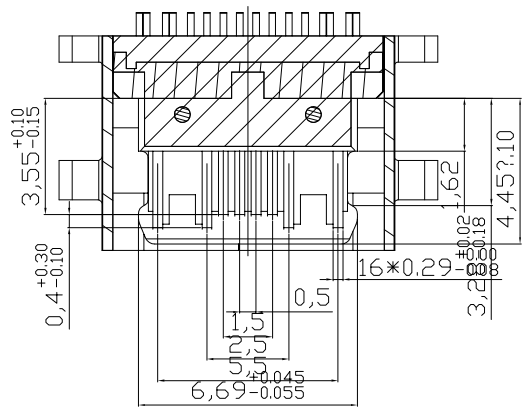

剖面 A-A

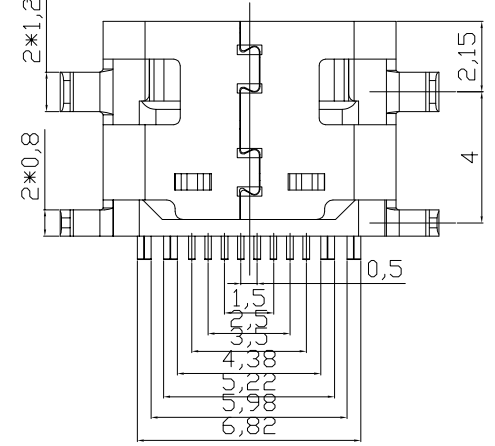

A1	GND	B12	GND
A4	VBUS	B9	VBUS
A5	CC1	B8	SBU2
A6	DP1	B7	DN2
A7	DN1	B6	DP2
A8	SBU1	B5	CC2
A9	VBUS	B4	VBUS
A12	GND	B1	GND
PIN	SIGNAL NAME	PIN	SIGNAL NAME



深圳市华德共创科技有限公司  
Shenzhen Huade co-create Technology Co., LTD  
电话: 0755-2711216 传真: 0755-29940187

-TOLERANCES- UNLESS OTHERWISE SPECIFIED 公差参数表		 	TITLE: 产品名称: USB TYPE C 沉板 0.8 单亮点 焊L=6.35					
X.X	±0.30	X.X*	±3°	APPD: 核准:	PART NO: 产品编号: TYPE C-GD-105PWB			
X.XX	±0.20	X.XX*	±2°	CHECK: 校对: 王建业	DATE	SCALE	UNIT	CODE NUMBER
X.XXX	±0.10	X.XXX*	±1°	DRAW: 绘图: 黄艳兰	2016-03-12	1:1	mm	A001