

NOTES:

Material:

Shell: Standard Brass
 Clip: Beryllium Copper

Finish:

91: Clip 0,25µm(10µ') Gold over Ni, Shell 5µm(200µ') Tin over Ni leaded
 For other plating configuration please consult.

Electrical:

Clip code 0710
 Rated current 15 Amps
 Contact resistance max. 15 milliohms

Mating Pin Size:

1,5 - 2,0 mm [,059' - ,078']

Environmental:

Temperature range : -55°C to +125°C

Mechanical:

Recommended PCB Mounting hole 3,47 mm [,136']
 Mechanical life min. 500 cycles

For complete mechanical and electrical specification, see CLIP
 Specification regarding Clip Code Number.

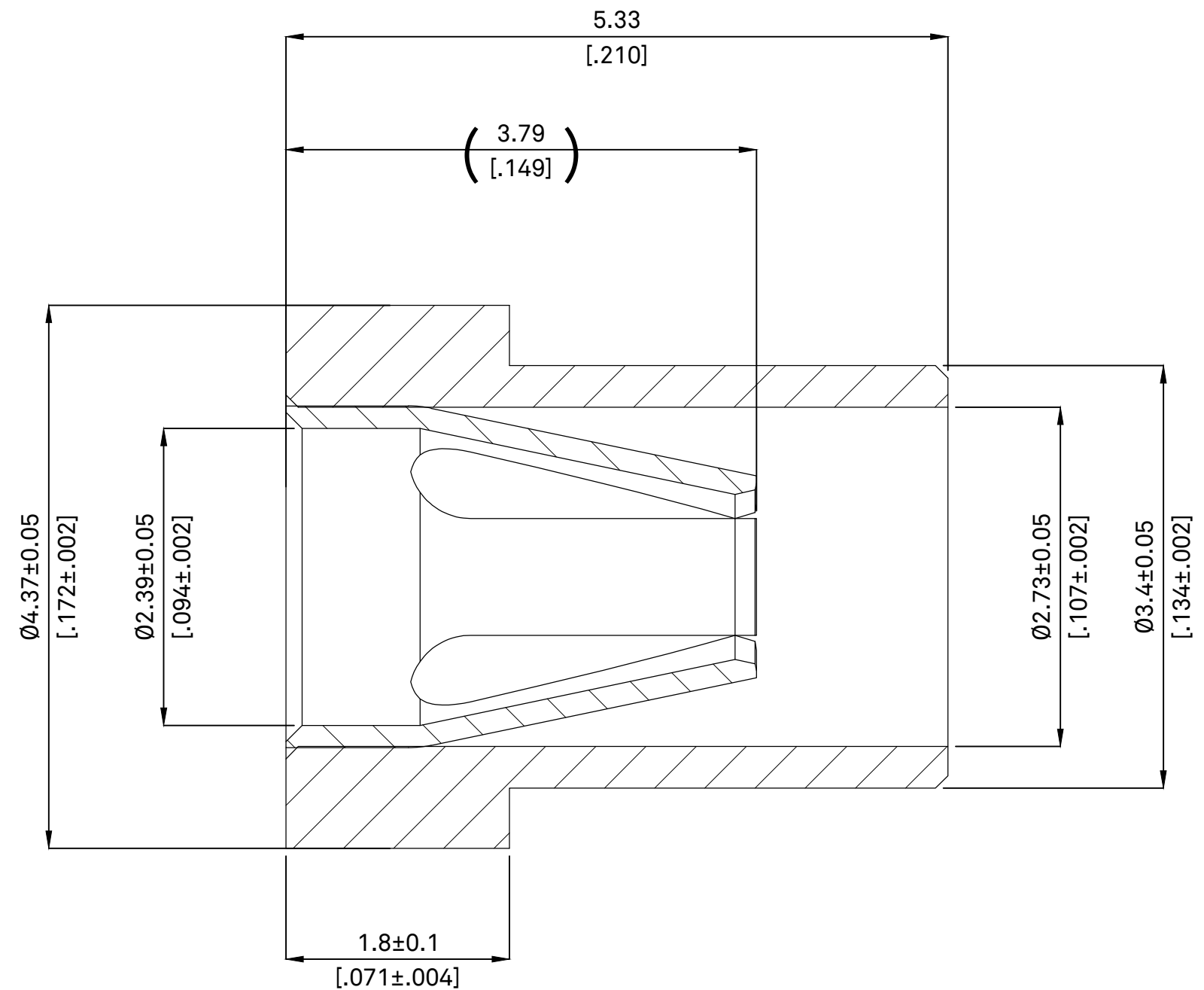

Socket Contact

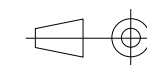

1:1

Remplace:

Remplace par:

Dessine	11.01.2023	C.Bidault
---------	------------	-----------

Controle		
----------	--	--

N° dessin	Revision
-----------	----------

15115-91-0710

