

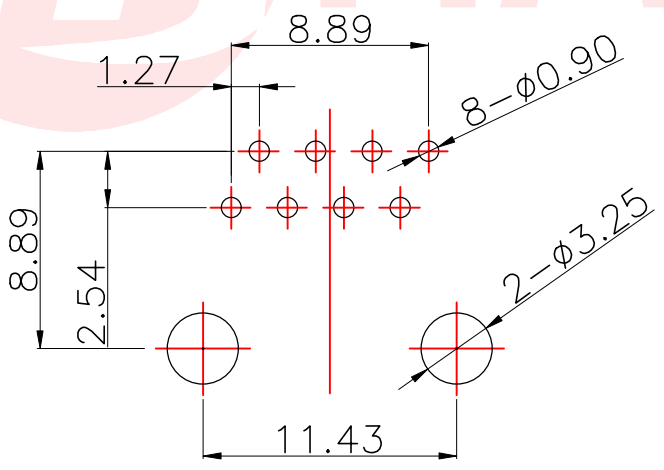

REV.	ECN NO OR DESCRIPTION	REVISED	DATE

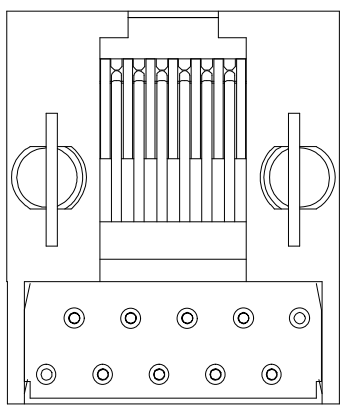
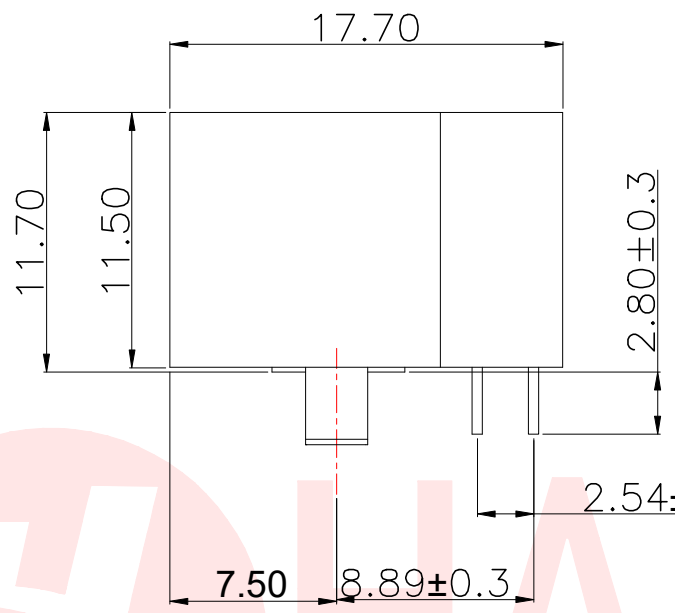
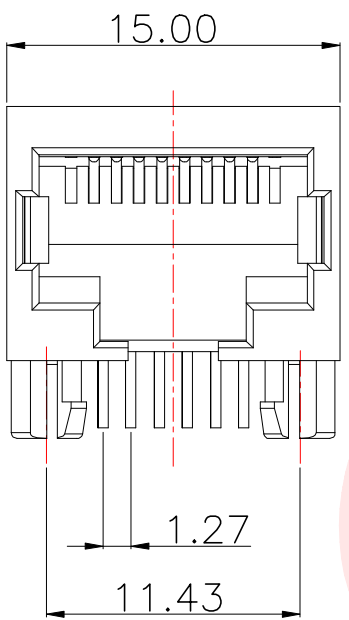

PCB LAYOUT

NOTES:

ELECTRICAL:

- VOLTAGE RATING: 125 VAC RMS.
- CURRENT RATING: 1.5 AMP.
- CONTACT RESISTANCE: 40 MILLIOHMS MAX.
- INSULATION RESISTANCE : 500 MEGOHMS MIN @ 100 VDC.
- DIELECTRIC STRENGTH: 500 VDC RMS 50Hz or 60Hz, 1MIN.

MECHANICAL:

- HOUSING & INSERT MATERIAL : HIGH TEMPERATURE PLASTIC UL94V-0.
- CONTACT MATERIAL: φ0.46 PHOSPHOR BRONZE GOLD PLATING OVER NICKEL.
- MATING/UNMATING FORCE : 2.24 KG.F MAX.
- OPERATING LIFE: 750 CYCLES MIN.

ENVIRONMENTAL:

- STORAGE: -40°C~+85°C.
- OPERATION : -40°C~+85°C.

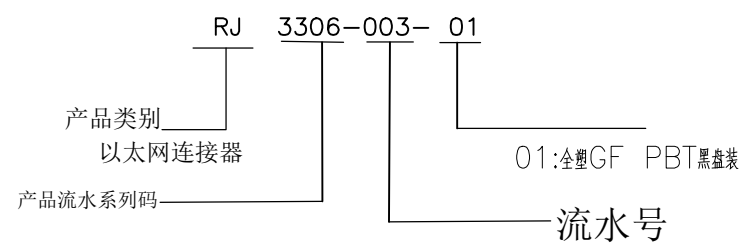
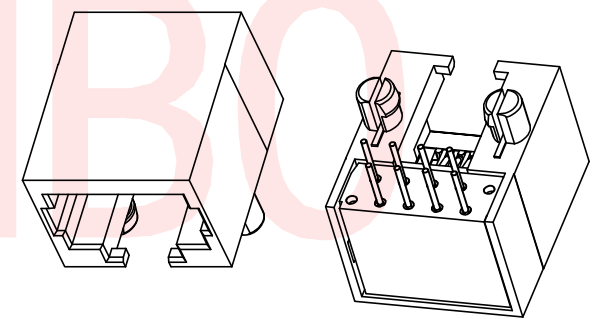

UNLESS OTHERWISE SPECIFIED TOLERANCES		东莞市汉博电子科技有限公司 DONGGUAN HANBO TECHNOLOGY CO., LTD			
DECIMALS:	ANGLES:	TITLE 5622 1x1全塑DIP 黑色 PBT			
X :±0.30	X :±2°	DWN	xiong	PART NO. RJ3306-003-01	
X.X :±0.20	X.X :±1°	CHKD	lee	SCALE:1:1	UNIT: mm
X.XX :±0.10		APVD	wang	SIZE: A4	SHEET:10F 1
		REV: A4			
CUSTOMER COPY					