

- No-load power consumption: 0.1W (TYP)
- Conversion efficiency: (87% typical)
- Switching frequency: 65KHz
- Output short-circuit, overcurrent, overvoltage, overtemperature protection
- Isolation voltage: 4000Vac
- Enclosure: Fully enclosed plastic enclosure, compliant with UL94V-0 standard
- Mounting method: PCB board through-hole mounting
- Standards: Compliant with CE and RoHS requirements

10W, wide-voltage input, isolated and regulated single-channel output



**Application Range**

The LH10-23BxxR2 series power supplies feature global input voltage range, AC/DC dual-use, low ripple, low temperature rise, low power consumption, high efficiency, high reliability, high safety isolation, and excellent EMC performance. EMC and safety specifications meet international standards EN55032 and IEC/EN61000. This series of products is widely used in various fields such as power systems, industry, instrumentation, and smart homes. When the product is used in an environment with harsh electromagnetic compatibility, please refer to the EMC application circuit provided by our company.

**Product Selection List**

C e r t i f i c a t i o n	Model	Output Specifications					Maximum Capacitive Load	Ripple and Noise @ 20MHz (Max)	Efficiency @ Full Load, 220Vac (Typical Value)
		Power	Voltage 1	Current 1	Voltage 2	Current 2			
		(W)	Vo1 (V)	Io2 (mA)	Vo2 (V)	Io2 (mA)			
	LH10-23B03R2	6.6	3.3	2000	--	--	2000	80	70
	LH10-23B05R2	10	5	2000	--	--	2000	80	80
	LH10-23B09R2	10	9	1111	--	--	1000	80	83
	LH10-23B12R2	10	12	833	--	--	1000	80	86
	LH10-23B15R2	10	15	666	--	--	1000	80	86
	LH10-23B24R2	10	24	416	--	--	470	80	87

**Notes:**

1. Due to space limitations, the above is only a partial product list. For products not included in the list, please contact the sales department of our company.
2. The typical value of output efficiency is based on the product being aged at full load for half an hour.
3. The fluctuation range of full-load efficiency (% , TYP) in the table is  $\pm 2\%$ . Full-load efficiency is calculated as

### Input Characteristics

Item	Operating Condition	Minimum	Typical	Maximum	Unit
Input voltage range	AC input	85	220	305	VAC
	DC input	120	310	432	VDC
Input frequency range		47	50	63	Hz
Input current	115VAC	/		0.25	A
	220VAC	/		0.12	A
Inrush current	115VAC	/		10	A
	220VAC	/		20	A
Leakage current		-	0.5mA	-	mA
		(TYP/230VAC/50Hz)			
Recommended external fuse		-	2A-4A/250VAC slow-blow fuse	-	-
Hot swapping		-	Not supported	-	-
Remote control terminal		-	No remote control terminal	-	-

### Output Characteristics

Item	Operating Condition	Minimum	Typical	Maximum	Unit
Voltage accuracy	Full input voltage range, any load	-	±1.0	±2.0	%
	(Vo1)				
	Full input voltage range, any load	-	±3.0	±5.0	%
	(Vo2)				

Line regulation	Nominal load (Vo1)	-	-	±0.5	%
	Nominal load (Vo2)	-	-	±1.5	%
Load regulation	Minimum load, nominal input voltage (Vo1)	-	-	±1.0	%
	20%~100% load (Vo2)	-	-	±3.0	%
No-load power consumption	Input 115VAC	-	-	0.1	W
	Input 220VAC	-	-	0.1	W
Start-up delay time	Single output	-	###	###	-
	Positive-negative dual output with common ground	-	10 (balanced load)	-	%
	Isolated positive-negative dual output	-	10 (balanced load)	-	%
Hold-up time	Nominal input voltage	1000	-	-	ms
	Input 115VAC	10	-	-	ms
	Input 220VAC	60	-	-	ms
Dynamic response	25%~50%~25% load	-	-	≤±5.0	%
	(Overshoot amplitude)				
	50%~75%~50% load	-	-	≤5.0	ms

	(Recovery time)				
Output overshoot	Full input voltage range	-	-	≤10% Vo	%
Short-circuit protection	Long-term short-circuit tolerant, self-recovering	-	Hiccup mode	-	-
Drift coefficient		-	±0.03	-	%/°C
Overcurrent protection	Full input voltage range	≥150% Io	-	-	-
	(Self-recovering, hiccup mode)				
Ripple & noise		50	-	100	mV

### General Characteristics

Item	Operating Condition	Minimum	Typical	Maximum	Unit
Switching frequency		-	65	-	KHz
Operating temperature		-40	-	+75	°C
Storage temperature		-40	-	+85	°C
Soldering temperature	Wave soldering	-	260±4	-	°C
	(Time: 5-10S)				
Soldering temperature	Manual soldering	-	360±8	-	°C
	(Time: 4-7S)				

Relative humidity		10	-	90	%RH
Isolation voltage	Input-output, test duration 1 minute, leakage current ≤5mA	3750	-	-	VAC
Insulation resistance	Input-output @ DC500V applied	100	-	-	MΩ
Safety standards		-	EN60950, IEC60950	-	-
Vibration	10-55Hz, 10G, 30Min, along X, Y, Z axes	-	-	-	-
Safety class		-	CLASS II	-	-
Enclosure class		-	UL94V-0	-	-
Mean Time Between Failures (MTBF)	MIL-HDBK-217F @ 25°C	-	>300,000	-	H

### EMC (Electromagnetic Compatibility) Characteristics

Main Item	Sub-item	Test Standard	Judgment Level
EMC	EMI	Conducted emission	CISPR22/EN55032 CLASS B
		Radiated emission	CISPR22/EN55032 CLASS B
	EMS	Radiated immunity	IEC/EN61000-4-3 10V/m Perf.Criteria B

EMC	Conducted immunity	IEC/EN61000-4-6 3Vr.m.s Perf.Criteria B
	Electrostatic Discharge (ESD)	IEC/EN61000-4-2 Contact ±6KV / Air ±8KV Perf.Criteria B
	Surge immunity	IEC/EN61000-4-5 ±1KV Perf.Criteria B
	Electrical Fast Transient (EFT) immunity	IEC/EN61000-4-4 ±2KV Perf.Criteria B
	Voltage dip, short interruption immunity	IEC/EN61000-4-11 0%~70% Perf.Criteria B

### General Characteristics

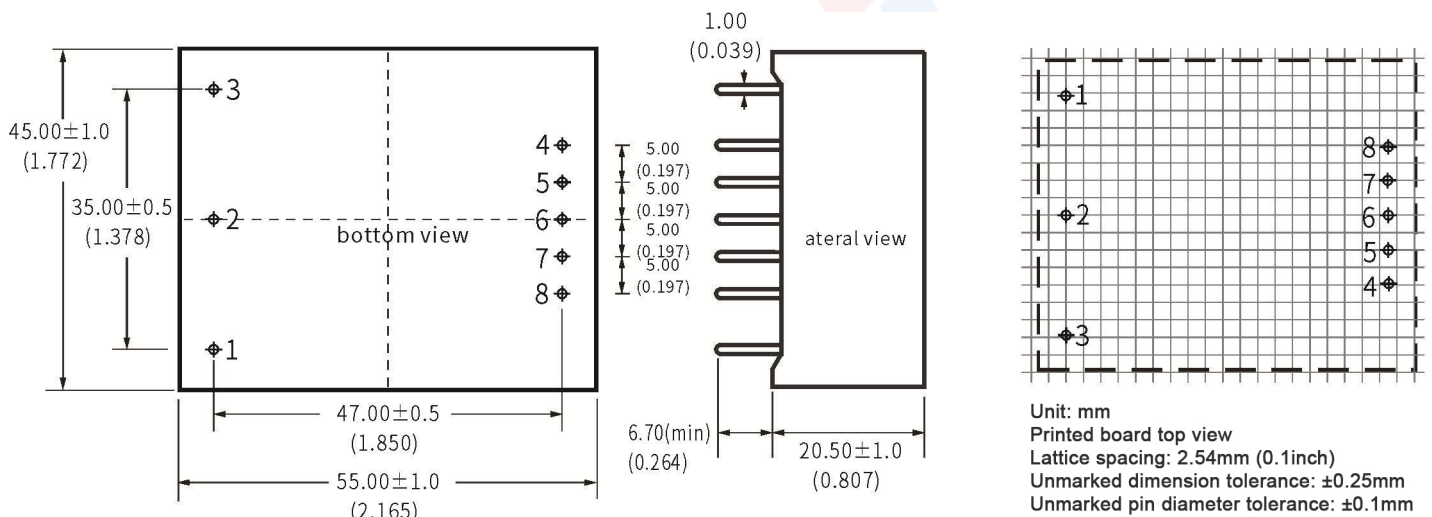

### Pin Definition

Pin Description	1	2	3	4	5	6	7	8
Single output	FG	AC (N)	AC (L)	+Vo	NP	NP	NP	-Vo
	(No function defined)	Input neutral line	Input live line	Output positive	Empty pin	Empty pin	Empty pin	Output negative

**Note:** If the pin definition of the power module is inconsistent with the selection manual, the marking on the physical label shall prevail.

Ripple & Noise Test Instructions (Twisted-Pair Method, 20MHz Bandwidth)

Test Method

1. Ripple and noise are measured using a 12# twisted-pair connection. The oscilloscope bandwidth is set to 20MHz, with a 100M bandwidth probe. A 0.1μF polypropylene capacitor and a 10μF high-frequency low-impedance electrolytic capacitor are connected in parallel at the probe end. The oscilloscope uses the "Sample" sampling mode.

2. Schematic diagram of output ripple and noise test: Connect the power input terminal to the input power supply. The power output is connected to the electronic load through a fixture board. For testing, a 30cm± 2cm sampling wire is used independently to sample directly from the power output port. The wire gauge of the power line is selected based on the magnitude of the output current, using insulated wires.

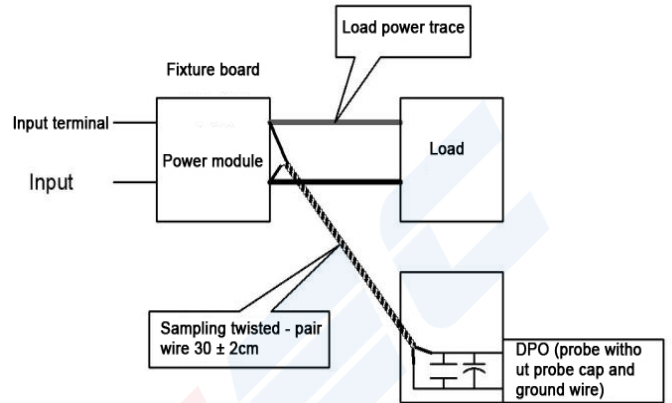

Product Characteristic Curves

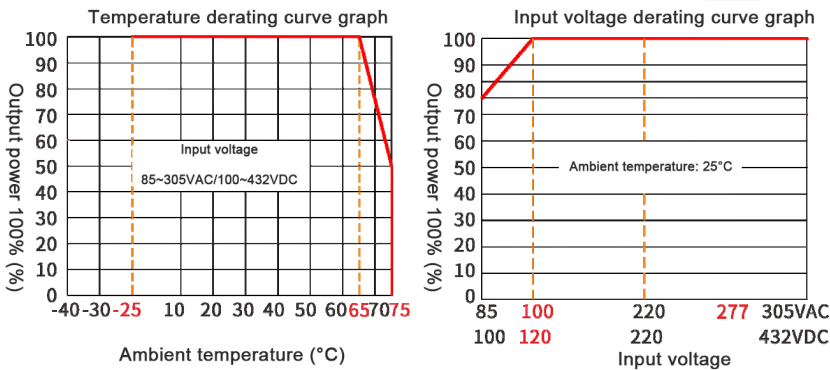

1. When the input voltage is 85~100VAC, the voltage derating shall be applied based on the input voltage derating curve.
2. This product is suitable for use in a natural air cooling environment. For use in a sealed environment, please contact our company.

Typical EMC application diagrams and recommended parameters

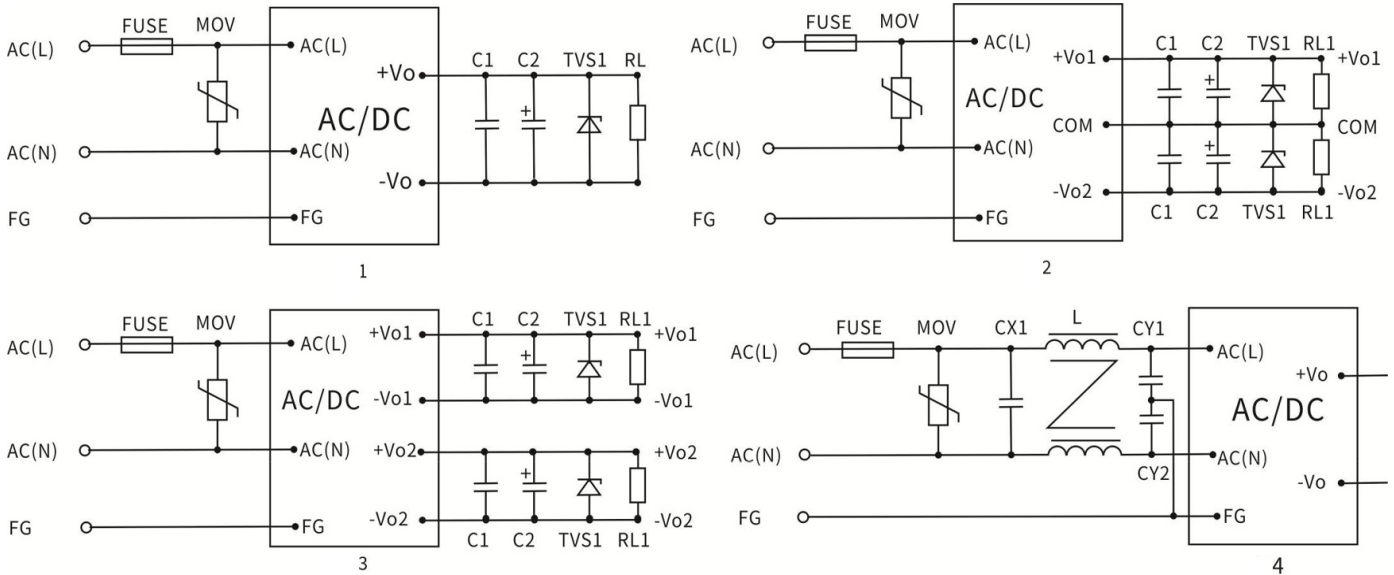

Notes:

1. Output filter capacitors C1 and C3 are used to remove high - frequency noise. It is recommended to use 1 $\mu$ F ceramic capacitors, and the voltage derating of the capacitors should be greater than 80%.
2. Output filter capacitors C2 and C4 are electrolytic capacitors. It is recommended to use high - frequency low - resistance electrolytic capacitors with a capacity of 100 $\mu$ F for 1A output current. The voltage derating of the capacitors is greater than 80%.
3. TVS tubes are recommended for protecting the subsequent circuit (when the module is abnormal). It is recommended to use 600W models. For 5V output, it is recommended to use: SMBJ7.0A; for 9V output, it is recommended to use: SMBJ12.0A; for 12V output, it is recommended to use: SMBJ20A; for 15V output, it is recommended to use: SMBJ20.0A; for 24V output, it is recommended to use: SMBJ30.0A; for 48V output, it is recommended to use: SMBJ64A.
4. MOV is a varistor. Recommended models: 10D561K (1000V surge) or 14D561K (2000V surge). Its function is to protect the module from damage during lightning surges.
5. For general application requirements of customers, please use the circuits recommended in Figure 1, Figure 2, and Figure 3. If there are higher EMC requirements, please use the circuit recommended in Figure 4. The specific recommended values for Figure 4 are as follows:
  - a. Varistor MOV: Recommended model: 14D - 561K. It is used to protect the module from damage during lightning surges.
  - b. Safety capacitors CY1, CY2: 1000pF/400VAC;
  - c. Safety capacitor CX: 0.1 $\mu$ F/275VAC;
  - d. Common - mode inductor LCM: 20mH - 30mH;
  - e. FUSE (fuse tube): Must be connected. The recommended specification is 3.15A/250V, slow - blow (If the fuse current is too small, it is easy to be damaged during surges; if it is too large, the protection function will be lost).

## Precautions

1. The product shall be used within the specified parameters; otherwise, permanent damage to the product may occur.
2. A fuse must be connected to the input terminal of the product.
3. If the product operates below the minimum required load, it cannot be guaranteed that all product performance indicators comply with those specified in this manual.
4. If the product operates beyond the specified load range, it cannot be guaranteed that all product performance indicators comply with those specified in this manual.
5. Unless otherwise specified, the above data are measured under the conditions of  $T_a=25^{\circ}\text{C}$ , humidity <75%, nominal input voltage, and rated output load (pure resistive load).
6. The test methods for all the above indicators are based on the standards of our company.
7. The above are the performance indicators of the product models listed in this manual. Some indicators of non-standard models may exceed the above requirements. For specific details, please contact the technical personnel of our company directly.
8. Our company can provide customized products.
9. Specifications are subject to change without prior notice.

Please refer to the latest manual published on our official website.