

特性 Features

- 最大150A触点切换能力 Max. 150A rating switching capability
- 最大80VDC负载开闭能力 Max. 80VDC switching capability
- 磁保持型继电器，功耗低 Latching type relay, power saving
- 辅助触点可选 Auxiliary contact available
- 外形尺寸 Outline dimensions: (39.5x 22.8 x 27.7)mm

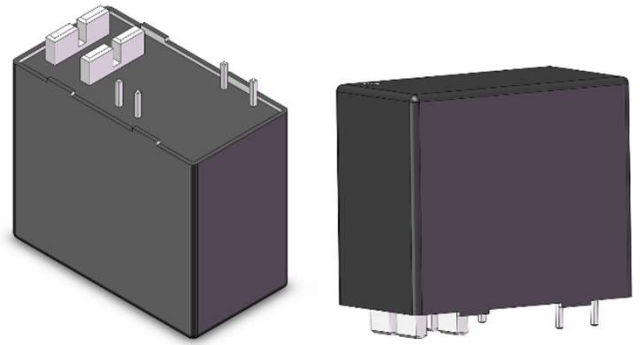

典型应用 Application

- PCS/BMS
- 直流电源 DC Power
- OBC

触点参数 Contact Data

触点形式 Contact Arrangement	1B/1A, 1B+1B/1A+1A
额定负载 Rated Load	150A 80VDC/277VAC
最大切换电压 Max. Switching Voltage	440VAC/80VDC
最大切换电流 Max. Switching Current	600A(5ms) 1ops
最小使用负载 Min. Available Load	12VDC @ 1A
触点材质 Contact Material	银合金 Ag alloy
接触电阻 Contact Resistance	Max.1mΩ (at 20A 6VDC)
动作/释放时间 Operate Time/ Release Time	≤30ms/≤30ms
电耐久性 Electrical Endurance*	on : off=1s:9s, R-Load, @85°C 125A/80VDC 6*10 ³ ops 150A/80VDC 3*10 ³ ops Making 50A, Carrying 150A, Breaking 50A/277VAC 1*10 ⁴ ops
机械耐久性 Mechanical Endurance	1*10 ⁵ ops. 18000 ops/h
最大切换功耗 Max. Switching Power	12000W

* 直流负载极性按推荐方向时 When the DC load polarity is in the recommended direction.

辅助触点规格 Auxiliary Contacts Specifications

辅助触点形式 Auxiliary Contacts Arrangement	1路常开 1 Form A 1路常闭 1 Form B
最大负载 Max. Load	80VDC 1A, 125VAC 1A
最小负载 Min. Load	8VDC 0.1A
接触电阻 Contact Resistance	<0.1Ω

线圈参数 Coil Data

线圈电压范围 Coil Voltage Range	12~60 VDC
容许最大电压 Max. Continuous	额定电压的200% 200% of Rated Voltage
线圈绝缘等级 Coil Insulation System	Class F
额定线圈功率 Coil Rating Power	7.7W
最小线圈脉冲宽度 Min. Coil Voltage Plus Width	200ms

注:

- 所有数值均为在环境温度+20°C下未预通电的线圈 All the performance data are for coils that are not pre energized at 20°C ambient temperature.
- 允许最大线圈电压是指继电器线圈在短时间内能够承受的最大电压值 Maximun allowable coil voltage refers to the maximun voltage which relay coil could endure in a short period of time.

性能参数 Characteristics

绝缘电阻 Insulation Resistance		100MΩ (500VDC)
介质耐压 Dielectric Strength	断开主触点间 Open Main Contacts	3000Vrms 1min
	线圈与触点间 Coil to Main Contacts	3000Vrms 1min
	辅助触点与主触点间 Auxiliary Contacts to Main Contacts	3000Vrms 1min
	线圈与辅助触点间 Coil to Auxiliary Contacts	2000Vrms 1min
温度范围 Temperature Range		-40~+85°C
湿度 Ambient Operating Humidity		5 ~ 95%RH
振动 Vibration Resistance		10~200Hz 3.5G
冲击 Shock	稳定性 Functional	20G
	强度 Destructive	50G
引出脚端子类型 External Terminal Type		PCB
耐热焊接 Soldering (Max.)		5±0.5s, 260±5°C 3.5±0.5s, 350±10°C

线圈规格 Coil Voltage Specifications

额定电压 Nominal Coil VDC	动作电压 Must Operate VDC	释放电压 Release Coil VDC	线圈电阻 Coil Resistance Ω
12	8.4	1.2	18.7
24	16.8	2.4	74.8
36	25.2	3.6	168.3
48	33.6	4.8	299.2
60	42.0	6.0	467.5

注:

- 以上值为初始值 All the performance data are initial values.
- 线圈电阻是在线圈温度23°C，公差为±20% Coil resistance is tested at 23°C ambient temperature, ±20% tolerance.

STEVO2-150 磁保持直流继电器 Latching DC Relay

■ 型号命名标准 Model Number Legend

基本型号 Basic Type: STEVO2	STEVO2	-150	-1B	D	-12	U	S	,XXX
触点负载 Contact Rating: 150: 150A								
触点结构 Contact Arrangement: 1A: 1组常开 1 Form A; 1B: 1组常闭 1 Form B								
辅助触点 Auxiliary Contact: Blank: 不带辅助触点 Without Auxiliary Contact; H: 带1组常开辅助触点 With 1 Form A Auxiliary Contact D: 带1组常闭辅助触点 With 1 Form B Auxiliary Contact								
线圈电压 Coil Voltage: 12, 24, 48, 60VDC								
线圈排序 Coil Sort: U: 单线圈 Single Coil								
保持构造 Protective Construction: Blank: 耐助焊剂型 Flux Tight; S: 塑料密封型 Sealed								
特殊特性 Special Characteristic: A00: 交流负载产品 AC Load Type; XXX: 客户特殊特性号 Customer Special Feature Number								

■ 外形尺寸、PCB 布局、接线图 Outline dimensions, PCB Layout, Wiring Diagram (mm)

◆ 外形尺寸 Outline dimensions

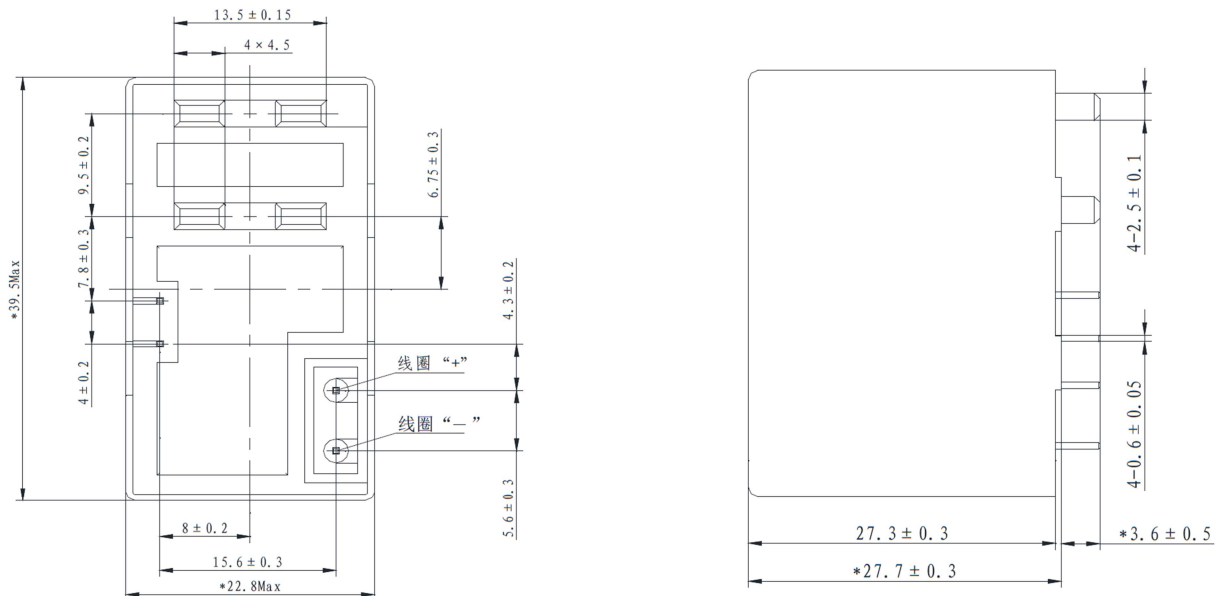

STEIV02-150 磁保持直流继电器 Latching DC Relay

■ 外形尺寸、PCB 布局、接线图 Outline dimensions, PCB Layout, Wiring Diagram (mm)

◆ 印刷电路板加工尺寸 PCB Outline Dimension Bottom View

● 带辅助触点 with Auxiliary Contact

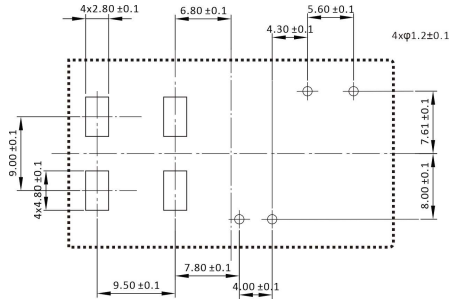

● 不带辅助触点 without Auxiliary Contact

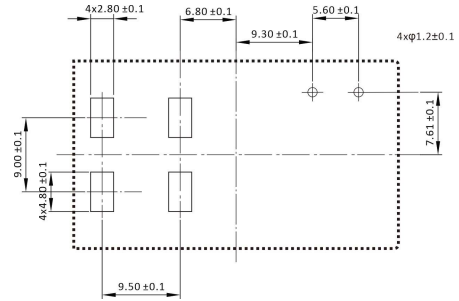

◆ 接线图 Wiring Diagram Bottom View

● 带辅助触点 with Auxiliary Contact

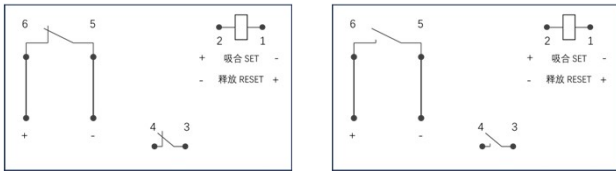

● 不带辅助触点 without Auxiliary Contact

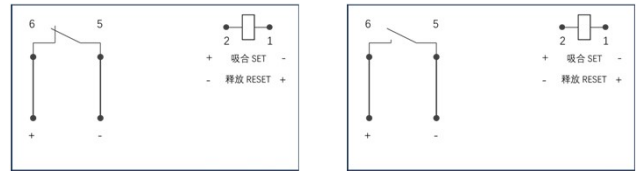

注 Note:

未注尺寸公差 Unspecified tolerance : <1mm: ±0.2 mm, 1~5 mm: ±0.3mm, >5mm: ±0.5 mm ;

安装孔尺寸中未注尺寸公差为± 0.1 mm PCB layout dimensions hadn't specified tolerance is ±0.1mm.

请注意:

1. 上面显示的数据是初始值。
2. 继电器在出库时处于“吸合”或“释放”状态，考虑中转冲击上升和继电器安装时，继电器将变为“吸合”或“释放”状态，因此，在应用（连接电源）时，请根据要求将继电器复位到“吸合”或“释放”状态。
3. 在运输、储存和操作产品过程中。请将产品置于远离磁场的地方避免操作电压和释放电压的变化。
4. 不要同时给“吸合”线圈和“释放”线圈通电。同时长时间通电（1分钟以上）应该避免。
5. 用于计量测量应用的继电器通常采用防尘结构，但大多数继电器可以根据客户的具体要求特制。这类继电器建议存放时间不超过6个月，并且请注意存放环境。如果客户无特殊要求，为确保接触可靠性，在交货时我们将保持继电器触点闭合状态。

Notice:

1. The data shown above are initial values.
2. Relay is on the “reset” or “set” status when being released from stock, with the consideration of shock risen from transit and relay mounting, relay would be changed to “set” or “reset” status, therefore, when application (connecting the power supply), please reset the relay to “set” or “reset” status on request.
3. During transportation, storage and operation the product. Please keep the product away from magnetic fields to avoid changes of operate and release voltage.
4. Do not energize voltage to “set” coil and “reset” coil simultaneously. And also long energized time (more than 1 min) should be avoided.
5. Relays used for metering measuring applications are usually made with dust proof structure, while most relays could be made specially per customer’s specific requirements. No longer than 6 months’ storage time is recommended for this kind of relay, and please pay attention to the storage environment. To ensure contact reliability, we will keep contact status be closed when delivery if no special required by customer.

免责声明:

本说明书仅供参考。

有关更多信息，请参阅“术语和指南”。规格如有更改，恕不另行通知。我们无法评估每个可能应用的所有性能和所有参数。因此，用户应该在一个正确的位置选择适合自己的产品。如有任何疑问或者需要技术服务，请联系STEIPU。

Disclaimer:

This manual is for reference only. For more information, see Terms and Guidelines. Specifications are subject to change without notice. We cannot evaluate all performance and all parameters for every possible application. Therefore, users should choose the right product for them in the right place. If you have any questions or need technical services, please contact STEIPU.