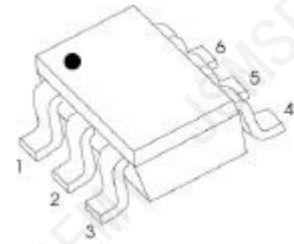

FEATURES

Epitaxial Die Construction

Two isolated NPN/PNP(BC847W+BC857W)

Transistors in one package

MAXIMUM RATINGS TR1 (T_a=25°C unless otherwise noted)

Symbol	Parameter	Value	Units
V _{CB0}	Collector-Base Voltage	50	V
V _{CE0}	Collector-Emitter Voltage	45	V
V _{EB0}	Emitter-Base Voltage	6	V
I _C	Collector Current –Continuous	0.1	A
P _C	Collector Power Dissipation	200	mW
T _J	Junction Temperature	150	°C
T _{stg}	Storage Temperature	-55-150	°C

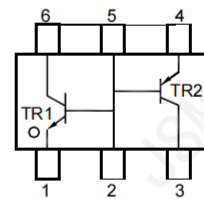
SOT-363
CHARACTERISTICS of TR1 (NPN Transistor) (T_a=25°C unless otherwise specified)

Parameter	Symbol	Test conditions	Min	Typ	Max	Unit
Collector-base breakdown voltage	V _{(BR)CBO}	I _C =10μA, I _E =0	50			V
Collector-emitter breakdown voltage	V _{(BR)CEO}	I _C =10mA, I _B =0	45			V
Emitter-base breakdown voltage	V _{(BR)EBO}	I _E =1μA, I _C =0	6			V
Collector cut-off current	I _{CBO}	V _{CB} =30V, I _E =0			15	nA
Emitter cut-off current	I _{EBO}	V _{EB} =5V, I _C =0			15	nA
DC current gain	h _{FE}	V _{CE} =5V, I _C =2mA	200		450	
Collector-emitter saturation voltage	V _{CE(sat)}	I _C =10mA, I _B =0.5mA			0.25	V
	V _{CE(sat)}	I _C =100mA, I _B =5mA			0.6	V
Base-emitter saturation voltage	V _{BE(sat)}	I _C =10mA, I _B =0.5mA		0.7		V
	V _{BE(sat)}	I _C =100mA, I _B =5mA		0.9		V
Base-emitter voltage	V _{BE(on)}	V _{CE} =5V, I _C =2mA	0.58		0.7	V
	V _{BE(on)}	V _{CE} =5V, I _C =10mA			0.72	V
Collector output capacitance	C _{ob}	V _{CB} =10V, I _E =0, f=1MHz			6.0	pF
Transition frequency	f _T	V _{CE} =5V, I _C =10mA, f=100MHz	100			MHz
Noise figure	NF	V _{CE} =5V, I _C =0.2mA, f=1kHz, R _g =2KΩ, Δf=200Hz			10	dB

MAXIMUM RATINGS TR2 ($T_a=25^{\circ}\text{C}$ unless otherwise noted)

Symbol	Parameter	Value	Units
V_{CBO}	Collector-Base Voltage	-50	V
V_{CEO}	Collector-Emitter Voltage	-45	V
V_{EBO}	Emitter-Base Voltage	-5	V
I_{C}	Collector Current –Continuous	-0.1	A
P_{C}	Collector Power Dissipation	200	mW
T_{J}	Junction Temperature	150	$^{\circ}\text{C}$
T_{stg}	Storage Temperature	-55-150	$^{\circ}\text{C}$

CHARACTERISTICS of TR2 (PNP Transistor) ($T_a=25^{\circ}\text{C}$ unless otherwise specified)

Parameter	Symbol	Test conditions	MIN	TYP	MAX	UNIT
Collector-base breakdown voltage	$V_{(\text{BR})\text{CBO}}$	$I_{\text{C}}=-10\mu\text{A}, I_{\text{E}}=0$	-50			V
Collector-emitter breakdown voltage	$V_{(\text{BR})\text{CEO}}$	$I_{\text{C}}=-10\text{mA}, I_{\text{B}}=0$	-45			V
Emitter-base breakdown voltage	$V_{(\text{BR})\text{EBO}}$	$I_{\text{E}}=-1\mu\text{A}, I_{\text{C}}=0$	-5			V
Collector cut-off current	I_{CBO}	$V_{\text{CB}}=-30\text{V}, I_{\text{E}}=0$			-15	nA
Emitter cut-off current	I_{EBO}	$V_{\text{EB}}=-5\text{V}, I_{\text{C}}=0$			-15	nA
DC current gain	h_{FE1}	$V_{\text{CE}}=-5\text{V}, I_{\text{C}}=-2\text{mA}$	220		475	
Collector-emitter saturation voltage	$V_{\text{CE}(\text{sat})}$	$I_{\text{C}}=-10\text{mA}, I_{\text{B}}=-0.5\text{mA}$			-0.3	V
	$V_{\text{CE}(\text{sat})}$	$I_{\text{C}}=-100\text{mA}, I_{\text{B}}=-5\text{mA}$			-0.65	V
Base-emitter saturation voltage	$V_{\text{BE}(\text{sat})}$	$I_{\text{C}}=-10\text{mA}, I_{\text{B}}=-0.5\text{mA}$		-0.7		V
	$V_{\text{BE}(\text{sat})}$	$I_{\text{C}}=-100\text{mA}, I_{\text{B}}=-5\text{mA}$			-0.95	V
Base-emitter voltage	$V_{\text{BE}(\text{on})}$	$V_{\text{CE}}=-5\text{V}, I_{\text{C}}=-2\text{mA}$	-0.6		-0.75	V
	$V_{\text{BE}(\text{on})}$	$V_{\text{CE}}=-5\text{V}, I_{\text{C}}=-10\text{mA}$			-0.82	V
Collector output capacitance	C_{ob}	$V_{\text{CB}}=-10\text{V}, I_{\text{E}}=0, f=1\text{MHz}$			4.5	pF
Transition frequency	f_{T}	$V_{\text{CE}}=-5\text{V}, I_{\text{C}}=-10\text{mA}, f=100\text{MHz}$	100			MHz
Noise figure	NF	$V_{\text{CE}}=-5\text{V}, I_{\text{C}}=-0.2\text{mA}, f=1\text{kHz}$ $R_{\text{g}}=2\text{K}\Omega, \Delta f=200\text{Hz}$			10	dB

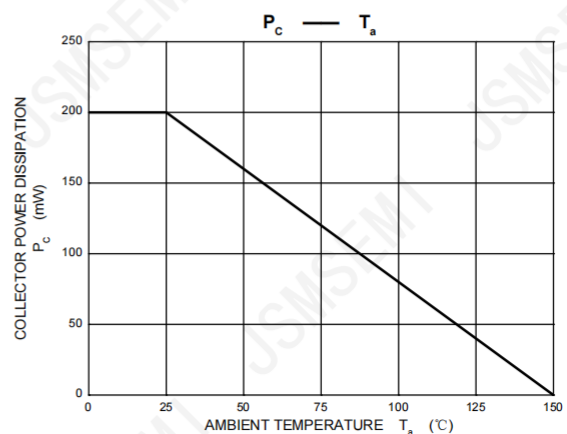
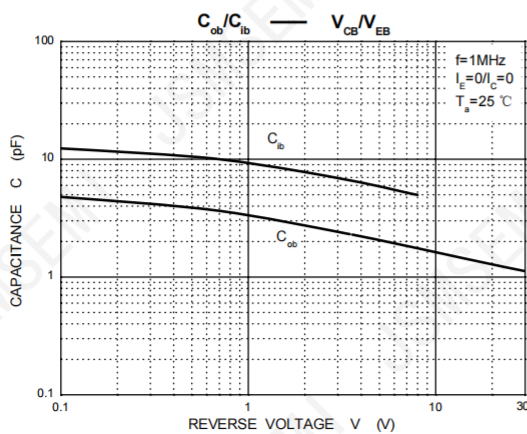
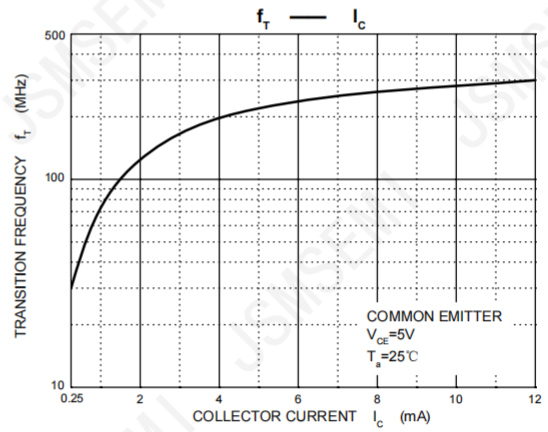
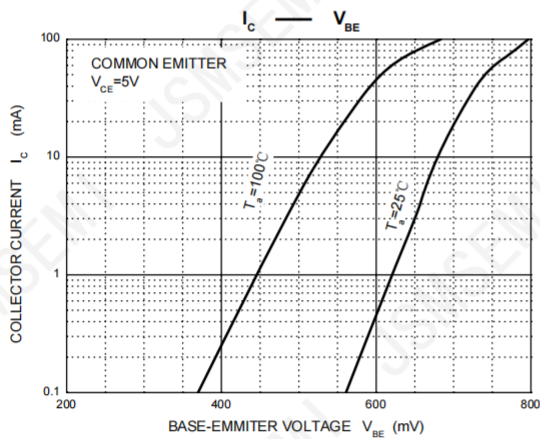
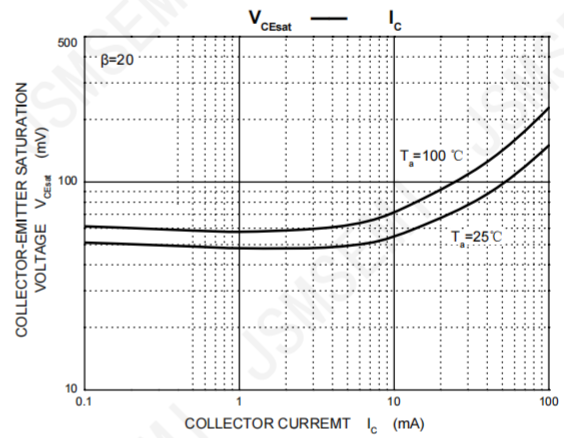
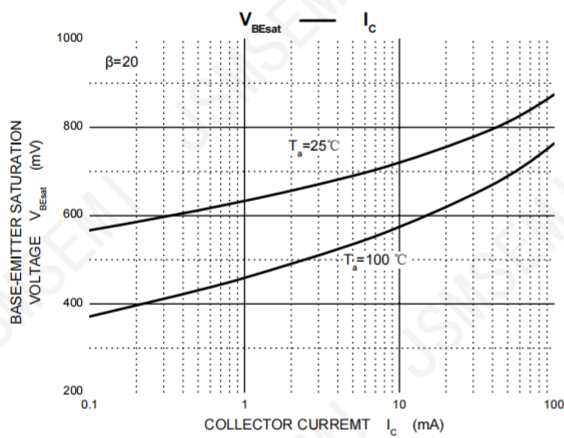
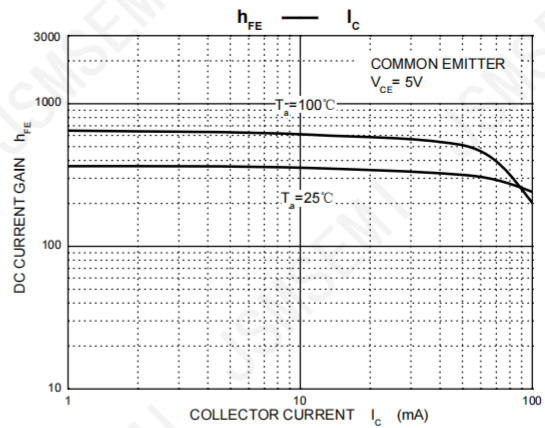
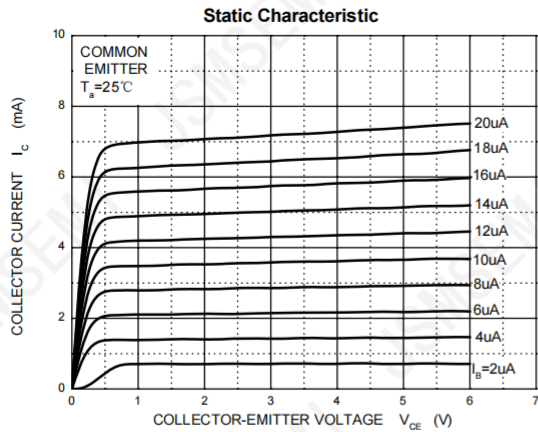

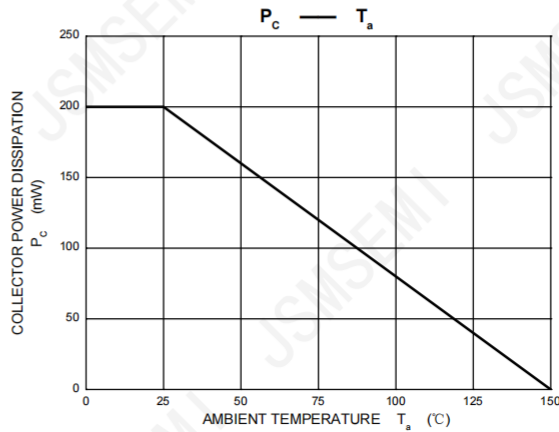
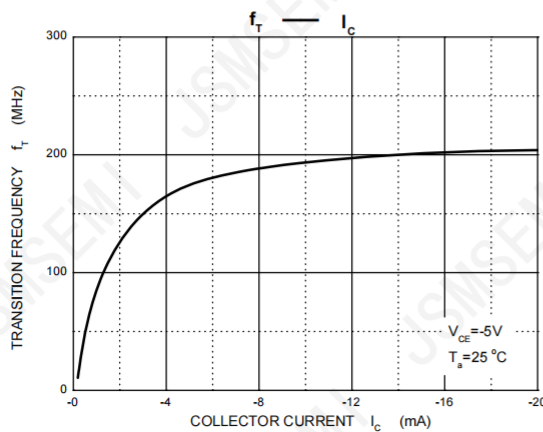
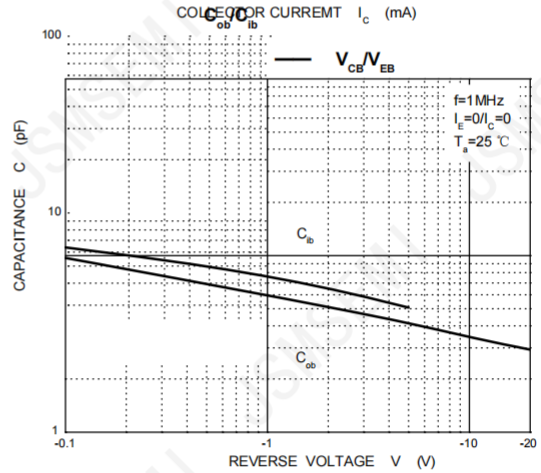
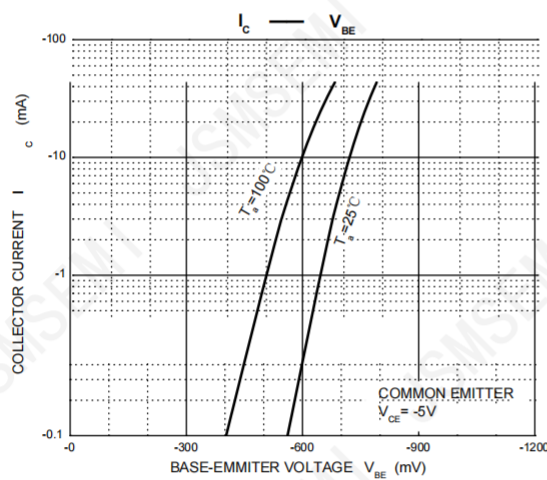
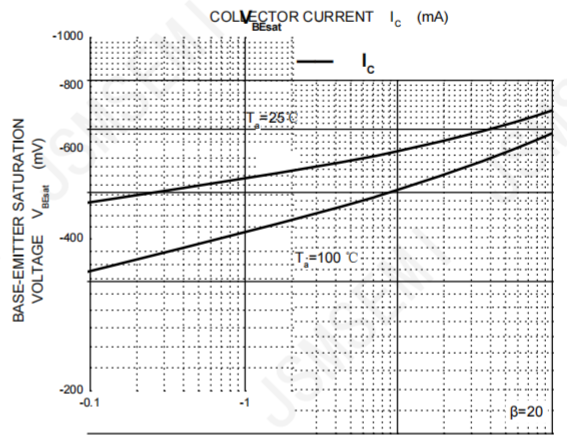
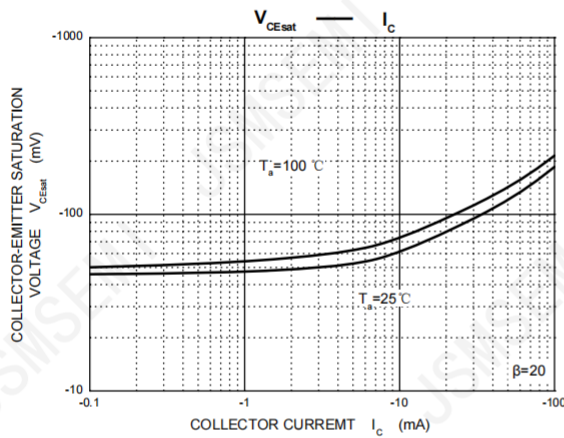
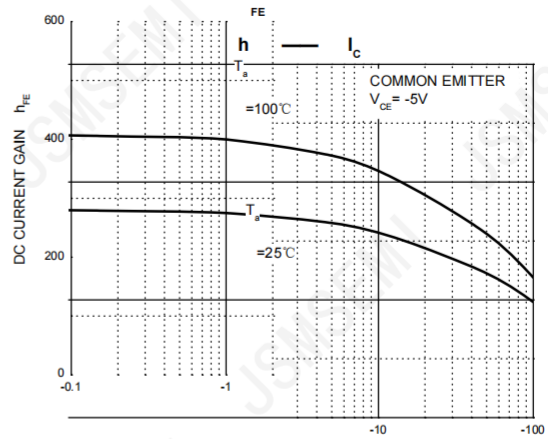
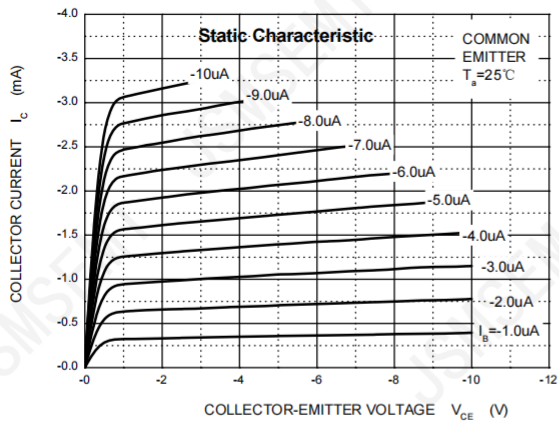

■ SOT-363

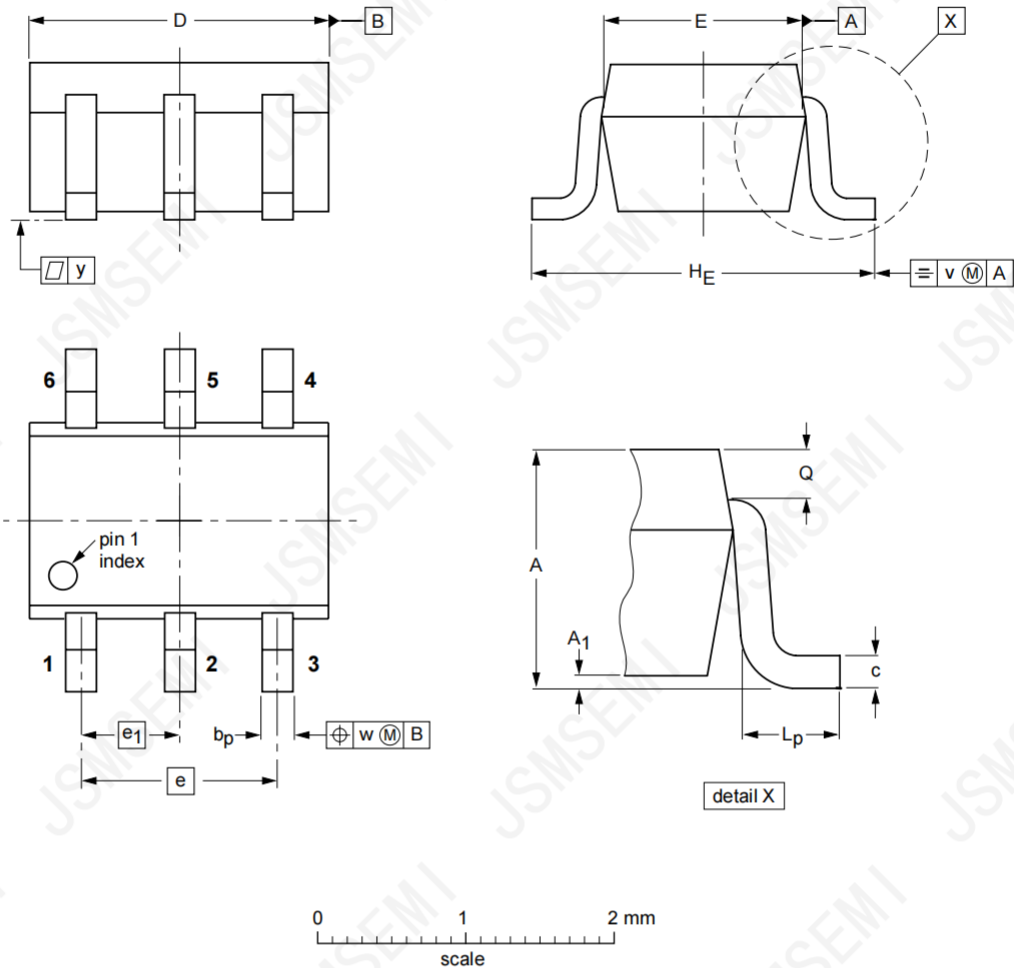

DIMENSIONS (mm are the original dimensions)

UNIT	A	A ₁ max	b _p	c	D	E	e	e ₁	H _E	L _p	Q	v	w	y
mm	1.1 0.8	0.1	0.30 0.20	0.25 0.10	2.2 1.8	1.35 1.15	1.3	0.65	2.2 2.0	0.45 0.15	0.25 0.15	0.2	0.2	0.1

Revision History

Rev.	Change	Date
V1.0	Initial version	2/23/2024

Important Notice

JSMSEMI Semiconductor (JSMSEMI) PRODUCTS ARE NEITHER DESIGNED NOR INTENDED FOR USE IN MILITARY AND/OR AEROSPACE, AUTOMOTIVE OR MEDICAL DEVICES OR SYSTEMS UNLESS THE SPECIFIC JSMSEMI PRODUCTS ARE SPECIFICALLY DESIGNATED BY JSMSEMI FOR SUCH USE. BUYERS ACKNOWLEDGE AND AGREE THAT ANY SUCH USE OF JSMSEMI PRODUCTS WHICH JSMSEMI HAS NOT DESIGNATED FOR USE IN MILITARY AND/OR AEROSPACE, AUTOMOTIVE OR MEDICAL DEVICES OR SYSTEMS IS SOLELY AT THE BUYER' S RISK.

JSMSEMI assumes no liability for application assistance or customer product design. Customers are responsible for their products and applications using JSMSEMI products.

Resale of JSMSEMI products or services with statements diferent from or beyond the parameters stated by JSMSEMI for that product or service voids all express and any implied warranties for the associated JSMSEMI product or s ervice. JSMSEMI is not responsible or liable for any such statements.

JSMSEMI All Rights Reserved. Information and data in this document are owned by JSMSEMI wholly and may not be edited, reproduced, or redistributed in any way without the express written consent from JSMSEMI.

Any and all information described or contained herein are subject to change without notice due to product/technology improvement, etc. When designing equipment, refer to the "Delivery Specification" for the JSMSEMI product that you intend to use.

For additional information please contact Kevin@jsmsemi.com or visit www.jsmsemi.com