

***MESSRS.***

---

## **SPECIFICATION FOR APPROVAL**

### **承 認 书**

<b>Product</b>	<b>ELECTRET CONDENSER MICROPHONE</b>
<b>Part No.</b>	<b>HMB-O60F36-CWH2 (RoHS)</b>
<b>Customer Part No.</b>	
<b>Customer Approval</b>	

<b>Approved By</b>	<b>Checked By</b>	<b>Made By</b>
王台平 JAN-26-2024	曹丽萍 JAN-26-2024	LILY JAN-26-2024

**常州华龙电子有限公司**  
**DRAGONSTATE ELECTRONIC CORPORATION**

中国江苏省常州市新区电子园新四路 36 号

**Tel: +86-519-85110078. 86-519-85106698, Fax: +86-519-85101081**

**1. 变更记录 (History change record)**

Change Items	Date	Note	Drawn by	Checked by
	2023-11-28	Frist Issue	Lily	王台平 2023-11-28
更改为 $\pi$ 型电路	2024-01-26	Second Issue	Lily	王台平 2024-01-26

**2. 储藏与判断条件 (Storage And Judgement Conditions)**

	Temperature Range(°C)	Rel. Humidity(% )	Static Pressure(kPa)
Judgement	-15~+35	63~67	86~106
Storage	-20~70		
Operating	-20~70		

### 3. 规格 (Specifications)

Test conditions( $V_S=2.0V$   $R_L=2.2k\Omega$   $Temp=20\pm 2^\circ C$   $R.H=60\pm 5\%$ )

Item	Symbol	Test Conditions	Min	Standard	Max	Unit
灵敏度 Sensitivity	S	f=1kHz,Pin=1Pa	-39	-36	-33	dB (0dB=1V/Pa)
阻抗 Impedance	Z	f=1kHz,Pin=1Pa			2.2	k $\Omega$
指向性 Directivity	Omni-directional					
消耗电流 Current Consumption	I				500	$\mu A$
工作电压 Operation Voltage Range	U		1.0	2.0	10	V
信噪比 S/N Ratio	S/N(A)	f=1kHz,Pin=1Pa A Curve		64		dB
降压特性 Decreasing Voltage Characteristic	$\Delta S$	f=1kHz,Pin=1Pa $V_S=2.0-1.5V$			-3	dB
失真 Distortion	THD	f=1kHz Pin=1Pa			1	%
最大输入声压 Max. Input Sound Level	MISPL	f=1kHz, Distortion<10%			120	dB

### 4. 测试电路 (Standard Test Circuit)

$V_S=2.0V$   $R_L=2.2k\Omega$   $T_e=20^\circ C$   $R.H.=60\%$

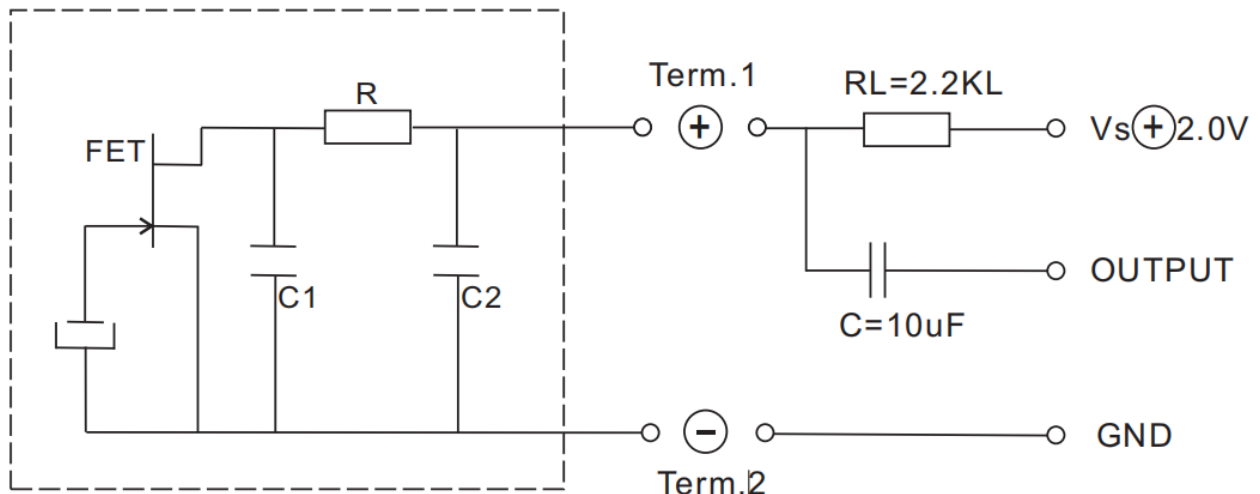

Circuit of the microphone

### 5. 测试装备图 (Standard Test Fixture)

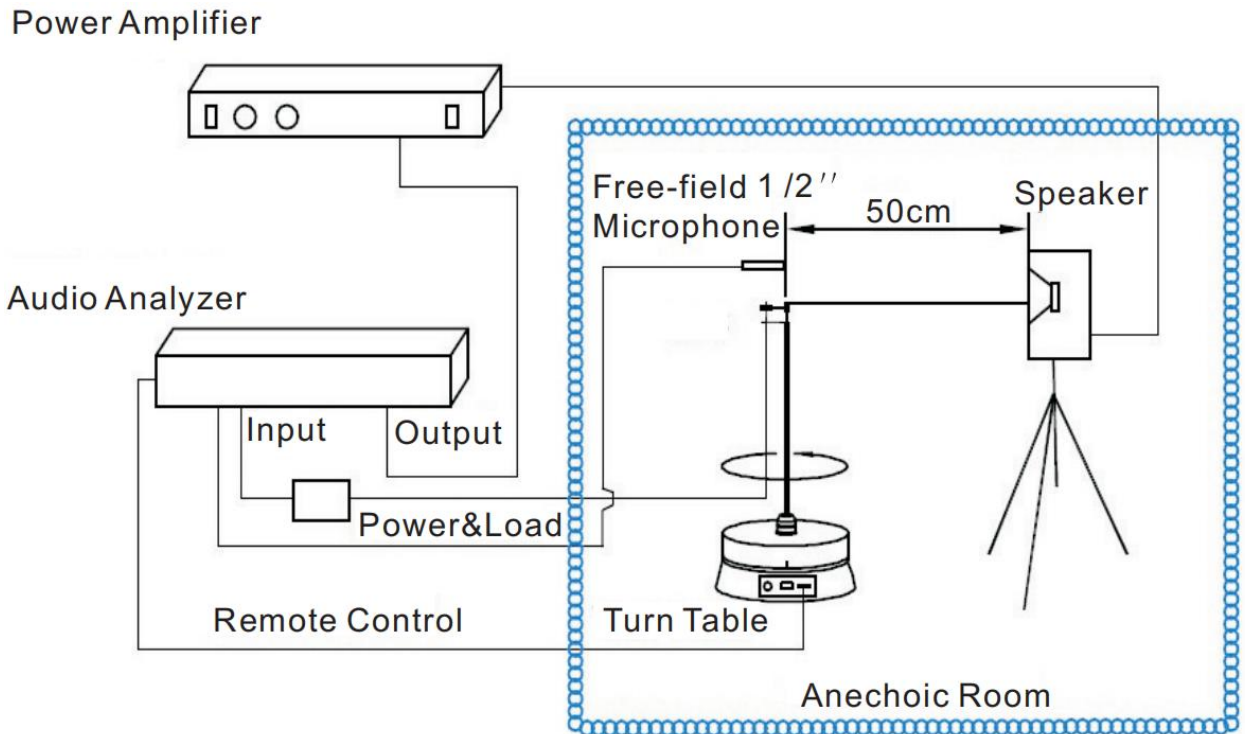

### 6 频响曲线 (Frequency Response Curve)

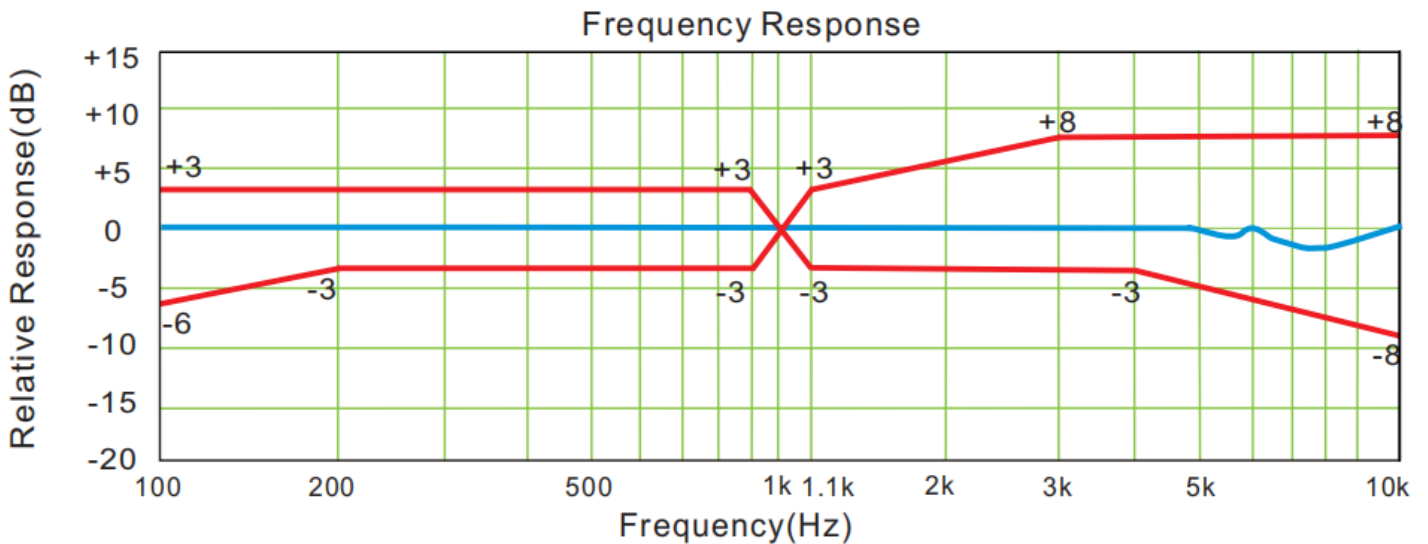

频率 (Hz)	100	200	900	1.0K	1.1K	3K	4K	10K
上限值 (dB)	+3	+3	+3	0	+3	+8	+8	+8
下限值 (dB)	-6	-3	-3	0	-3	-3	-3	-8

7,外观图 (Appearance Drawing)

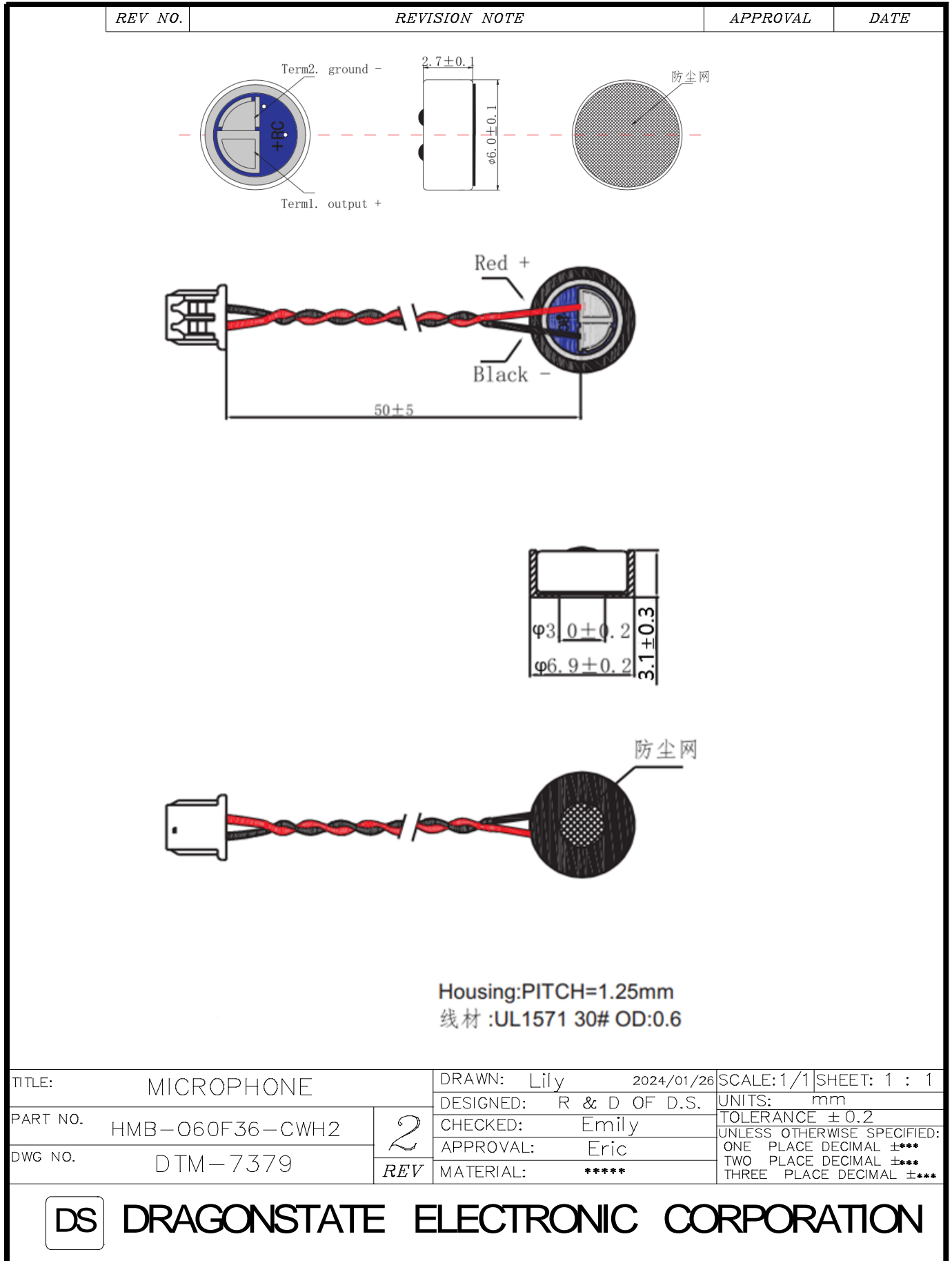

## 8. 可靠性试验 (Reliability Test)

在下列试验完成后,在温度为 20°C,相对湿度为 65%的条件下恢复 3 小时后进行测试,灵敏度与初始灵敏度相差在 ±3dB 以内.

(All tests should be done after 3 hours of conditioning at 20°C, R.H65%, while the sensitivity is to be within ±3dB,from the initial sensitivity after the following experiments.)

### 8.1 高温试验 (HIGH TEMPERATURE TEST)

温度(High temperature): +70°C

放置时间(Duration): 72hours

### 8.2 低温试验 (LOW TEMPERATURE TEST)

温度(Low temperature): -20°C

放置时间(Duration): 72 hours

### 8.3 温度循环试验(如图 1) (TEMPERATURE CYCLE TEST)(See in Fig.1)

低温(Low temperature): -20°C

高温(High temperature): +70°C

转化时间(Changeover time): 30min

放置时间(Duration): 60min

次数(Cycle): 10

### 8.4 湿度 (STATICAL HUMIDITY TEST)

温度(Temperature): +40°C

相对湿度(Relative humidity): 90 ~ 95%

放置时间(Duration): 240hours

#### 8.5 振动试验 (VIBRATION TEST)

振幅(Amplitude): 1.52mm

持续时间(Duration): 1 分钟/面( minutes/plane)

频度范围(Freq.range): 10 ~ 55Hz

试验时间(Total time): 2 小时(hour)

#### 8.6 跌落试验 (DROP TEST)

不带包装的跌落到 20mm 厚的地板上( Drop a unit unpacked onto a board of 20mm thick)

高度(Height): 1 m

次数(Cycle): 6 (1 each plane)

## 9. 焊接要求 (Regarding the Soldering operation)

每个驻极体电容传声器在其麦克风上都有一个 FET,这种 FET 在过热和电流撞击时易损坏,所以对于焊接应遵循以下操作:

- 要求使用 25W-35W 烙铁,并保持  $350\pm 10^{\circ}\text{C}$  的温度范围.
- 在每一个端的焊接应在 2 秒内完成,以防过热.
- 禁止单体麦克风焊接.(否则会影响驻极体电容传声器的灵敏度)
- 最理想的散热装置按以下设计.

Every ECM contains a FET with microphone body.

This FET easy to damageable from excessive heat and electrical shock. Proper attention for the soldering work is

required same as followings.

- Recommend to use 25W-35W ceramic soldering iron and apply  $350\pm 10^{\circ}\text{C}$  temperature range
- Soldering should be accomplished within 2 seconds at each terminal so as not to be overheated.
- Do not make a cavity at the surface of lead lump on the PCB. wiring board.

(Opened cavity will influence to the sensitivity of ECM)

- Optimal design for heat sink pad is same as below.

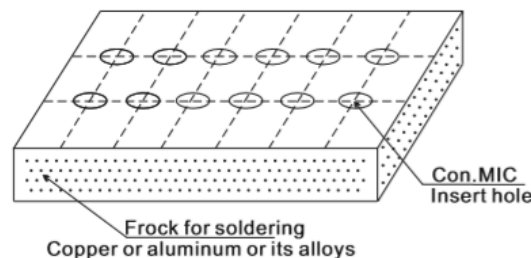

Shape of the individual hole

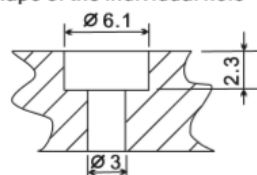

**11. 包装规格 (Packing Specifications)**

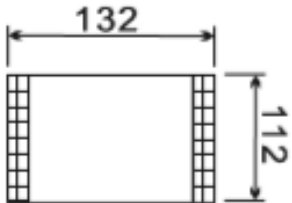
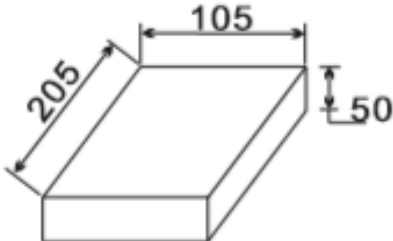
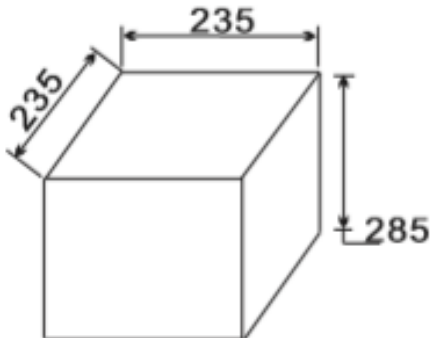
	Drawing(Unit:mm)	Qty(pcs.)	Material	Marking
Packing		100	ESD Bag	Particular for 9.2.1
Middle Box		1000	Paper	Particular for Customer s P.O
Outer Box		10000	Paper	Particular for Customer s P.O