

Features

- Wide supply voltage range from 0.9V to 3.6V
- Inputs accept voltages up to 3.6V
- I_{OFF} supports partial-power-down mode
- Low static power consumption; I_{CC}=0.5μA (Max.)
- ESD Protection Exceeds JESD 22
 - 2000-V Human-Body Model (A114-A)
 - 200-V Machine Model (A115-A)
 - 1000-V Charged-Device Model (C101)

General Description

The NC7SV02P5X-TP is a low-power single 2-input positive-NOR gate which provides the Function $Y = \overline{A+B}$ or $Y = \overline{A} \cdot \overline{B}$ in positive logic. This device ensures a very low static and dynamic power consumption across the entire VCC range from 0.9V to 3.6V.

Applications

- AV Receiver
- Audio Dock: Portable
- Blu-ray Player and Home Theater
- Embedded PC
- Personal Digital Assistant(PDA)
- Power: Telecom/Server AC/DC Supply: Single Controller: Analog and Digital
- Solid State Drive(SSD): Client and Enterprise
- Wireless Headset, Keyboard, and Mouse

Logic Diagram

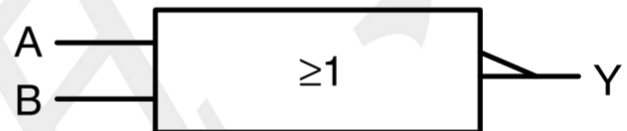

Ordering Information

ORDER NUMBER	PACKAGE DESCRIPTION	PACKAGE OPTION
NC7SV02P5X-TP	SOT353	Tape and Reel, 3000

Pin Configuratio (TOP VIEW)

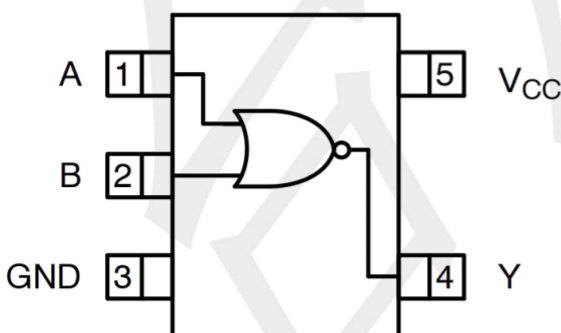

SOT353

Function Table (each gate)

Input		Output
A	B	Y
L	L	H
L	H	L
H	L	L
H	H	L

Note: H: HIGH voltage level; L: LOW voltage level.

Absolute Maximum Ratings

PARAMETER	SYMBOL	CONDITIONS	RATINGS	UNIT
Supply Voltage	V _{CC}		-0.5 ~ +4.3	V
Input Voltage	V _{IN}		-0.5 ~ +4.3	V
Output Voltage	V _{OUT}	Output in the high or low state	-0.5 ~ +V _{CC} +0.5V	V
		Output in the power-off state	-0.5 ~ +4.3	V
VCC or GND Current	I _{CC}		±50	mA
Continuous Output Current	I _{OUT}	V _{OUT} =0~V _{CC}	±20	mA
Input Clamp Current	I _{IK}	V _{IN} <0	-50	mA
Output Clamp Current	I _{OK}	V _{OUT} <0	-50	mA
Storage Temperature Range	T _{STG}		-65 ~ +150	°C
Junction to Ambient	θ _{JA}	SOT353	280	°C/W

Note: Absolute maximum ratings are those values beyond which the device could be permanently damaged. Absolute maximum ratings are stress ratings only and functional device operation is not implied.

Recommended Operating Conditions

PARAMETER	SYMBOL	TEST CONDITIONS	MIN	TYP	MAX	UNIT
Supply Voltage	V _{CC}	Operating	0.9	--	3.6	V
Input Voltage	V _{IN}		0	--	3.6	V
Output Voltage	V _{OUT}	High or low state	0	--	V _{CC}	V
Input Transition Rise or Fall Rate	Δt/Δv	V _{CC} =0.9V ~ 3.6V	--	--	200	ns/V
Operating Temperature	T _A		-40	--	+125	°C

Electrical Characteristics (T_A=25°C ,unless otherwise specified)

PARAMETER	SYMBOL	TEST CONDITIONS	MIN	TYP	MAX	UNIT	
High-level Input Voltage	V _{IH}	V _{CC} =0.9V	0.7×V _{CC}	--	--	V	
		V _{CC} =1.1V ~ 1.95V	0.65×V _{CC}	--	--	V	
		V _{CC} =2.3V ~ 2.7V	1.6	--	--	V	
		V _{CC} =3V ~ 3.6V	2	--	--	V	
Low-level Input Voltage	V _{IL}	V _{CC} =0.9V	--	--	0.3×V _{CC}	V	
		V _{CC} =1.1V ~ 1.95V	--	--	0.35×V _{CC}	V	
		V _{CC} =2.3V ~ 2.7V	--	--	0.7	V	
		V _{CC} =3V ~ 3.6V	--	--	0.9	V	
High-Level Output Voltage	V _{OH}	V _{CC} =0.9 ~ 3.6V, I _{OH} =-20μA	V _{CC} -0.1	--	--	V	
		V _{CC} =1.1V, I _{OH} =-1.1mA	0.75×V _{CC}	--	--	V	
		V _{CC} =1.4V, I _{OH} =-1.7mA	1.11	--	--	V	
		V _{CC} =1.65V, I _{OH} =-1.9mA	1.32	--	--	V	
		V _{CC} =2.3V	I _{OH} =-2.3mA	2.05	--	--	V
			I _{OH} =-3.1mA	1.9	--	--	V
		V _{CC} =3V	I _{OH} =-2.7mA	2.72	--	--	V
			I _{OH} =-4mA	2.6	--	--	V
Low-Level Output Voltage	V _{OL}	V _{CC} =0.9 ~ 3.6V, I _{OL} =20μA	--	--	0.1	V	
		V _{CC} =1.1V, I _{OL} =1.1mA	--	--	0.3×V _{CC}	V	
		V _{CC} =1.4V, I _{OL} =1.7mA	--	--	0.31	V	
		V _{CC} =1.65V, I _{OL} =1.9mA	--	--	0.31	V	
		V _{CC} =2.3V	I _{OL} =2.3mA	--	--	0.31	V
			I _{OL} =3.1mA	--	--	0.44	V
		V _{CC} =3V	I _{OL} =2.7mA	--	--	0.31	V
			I _{OL} =4mA	--	--	0.44	V
Input Leakage Current	I _{I(LEAK)}	V _{CC} =0 ~ 3.6V, V _{IN} =GND ~ 3.6V	--	--	±0.1	μA	
Power OFF Leakage Current	I _{off}	V _{CC} =0 V, V _{IN} or V _{OUT} =0 ~ 3.6V	--	--	±0.2	μA	
Additional Power OFF Leakage Current	ΔI _{off}	V _{CC} =0 V~0.2V, V _{IN} or V _{OUT} =0 ~ 3.6V	--	--	±0.2	μA	
Quiescent Supply Current	I _{CC}	V _{CC} =0.9 ~3.6V, V _{IN} =V _{CC} or GND, I _{OUT} =0	--	--	0.5	μA	
Additional Quiescent Supply Current Per Input Pin	ΔI _{CC}	V _{CC} =3.3 V, V _{IN} =V _{CC} -0.6V, I _{OUT} =0	--	--	40	μA	
Input Capacitance	C _I	V _{CC} =0V-3.6V, V _{IN} =V _{CC} or GND	--	1.5	--	pF	
Output Capacitance	C _{OUT}	V _{CC} =0V, V _{OUT} =GND	--	3	--	pF	

OPERATING CHARACTERISTICS (f=10MHz, TA =25°C , unless otherwise specified)

PARAMETER	SYMBOL	TEST CONDITIONS	MIN	TYP	MAX	UNIT
Power Dissipation Capacitance	C _{PD}	V _{CC} =0.9V	--	4.1	--	pF
		V _{CC} =1.2±0.1V	--	4.1	--	pF
		V _{CC} =1.5±0.1V	--	4.1	--	pF
		V _{CC} =1.8±0.15V	--	4.1	--	pF
		V _{CC} =2.5±0.2V	--	4.2	--	pF
		V _{CC} =3.3±0.3V	--	4.3	--	pF

SWITCHING CHARACTERISTICS (TA =25°C, unless otherwise specified)

PARAMETER	SYMBOL	TEST CONDITIONS	MIN	TYP	MAX	UNIT	
Propagation delay from inputs (A or B) to output(Y)	t _{PD}	CL=5pF, RL=1MΩ	V _{CC} =0.9V	--	19.3	--	ns
			V _{CC} =1.2±0.1V	2.6	7.3	--	ns
			V _{CC} =1.5±0.1V	1.4	5.2	--	ns
			V _{CC} =1.8±0.15V	1	4.2	--	ns
			V _{CC} =2.5±0.2V	1	3	--	ns
			V _{CC} =3.3±0.3V	1	2.4	--	ns
		CL=10pF, RL=1MΩ	V _{CC} =0.9V	--	22.3	--	ns
			V _{CC} =1.2±0.1V	1.5	8.5	--	ns
			V _{CC} =1.5±0.1V	1	6.2	--	ns
			V _{CC} =1.8±0.15V	1	5	--	ns
			V _{CC} =2.5±0.2V	1	3.6	--	ns
			V _{CC} =3.3±0.3V	1	2.9	--	ns
		CL=15pF, RL=1MΩ	V _{CC} =0.9V	--	25	--	ns
			V _{CC} =1.2±0.1V	3.6	9.9	--	ns
			V _{CC} =1.5±0.1V	2.3	7.2	--	ns
			V _{CC} =1.8±0.15V	1.6	5.8	--	ns
			V _{CC} =2.5±0.2V	1	4.3	--	ns
			V _{CC} =3.3±0.3V	1	3.4	--	ns
		CL=30pF, RL=1MΩ	V _{CC} =0.9V	--	34.6	--	ns
			V _{CC} =1.2±0.1V	4.9	13.1	--	ns
			V _{CC} =1.5±0.1V	3.4	9.5	--	ns
			V _{CC} =1.8±0.15V	2.5	7.7	--	ns
			V _{CC} =2.5±0.2V	1.8	5.7	--	ns
			V _{CC} =3.3±0.3V	1.5	4.7	--	ns

TEST CIRCUIT AND WAVEFORMS

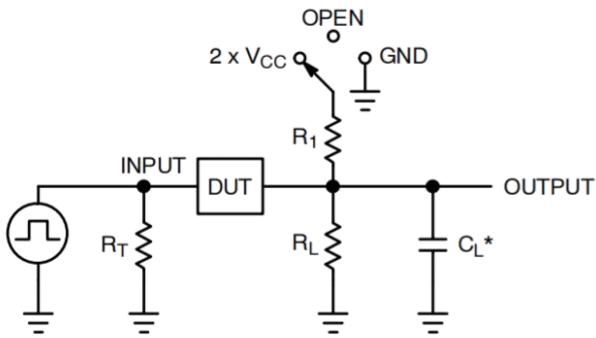

C_L includes probe and jig capacitance
 R_T is Z_{OUT} of pulse generator (typically 50 Ω)
 $f = 1$ MHz

Test	Switch Position
t_{PLH} / t_{PHL}	Open
t_{PLZ} / t_{PZL}	$2 \times V_{CC}$
t_{PHZ} / t_{PZH}	GND

Test Circuit

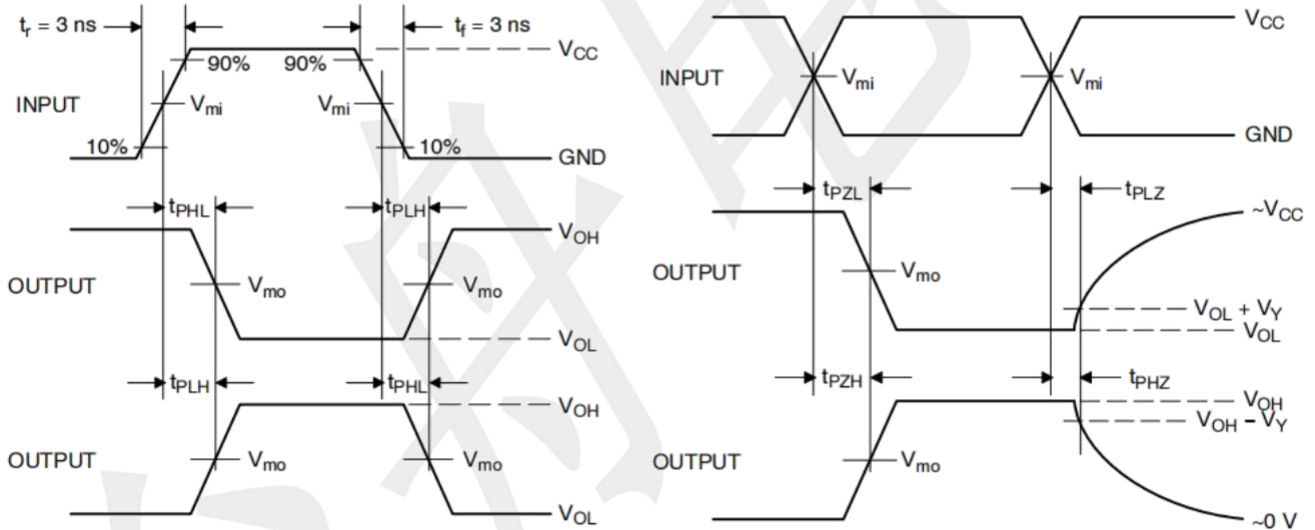

V_{CC}, V	V_{mi}, V	V_{mo}, V	V_Y, V
0.9	$V_{CC} / 2$	$V_{CC} / 2$	0.1
1.1 to 1.3	$V_{CC} / 2$	$V_{CC} / 2$	0.1
1.4 to 1.6	$V_{CC} / 2$	$V_{CC} / 2$	0.1
1.65 to 1.95	$V_{CC} / 2$	$V_{CC} / 2$	0.15
2.3 to 2.7	$V_{CC} / 2$	$V_{CC} / 2$	0.15
3.0 to 3.6	1.5	1.5	0.3

Switching Waveforms

Package information (Unit: mm)

SOT353

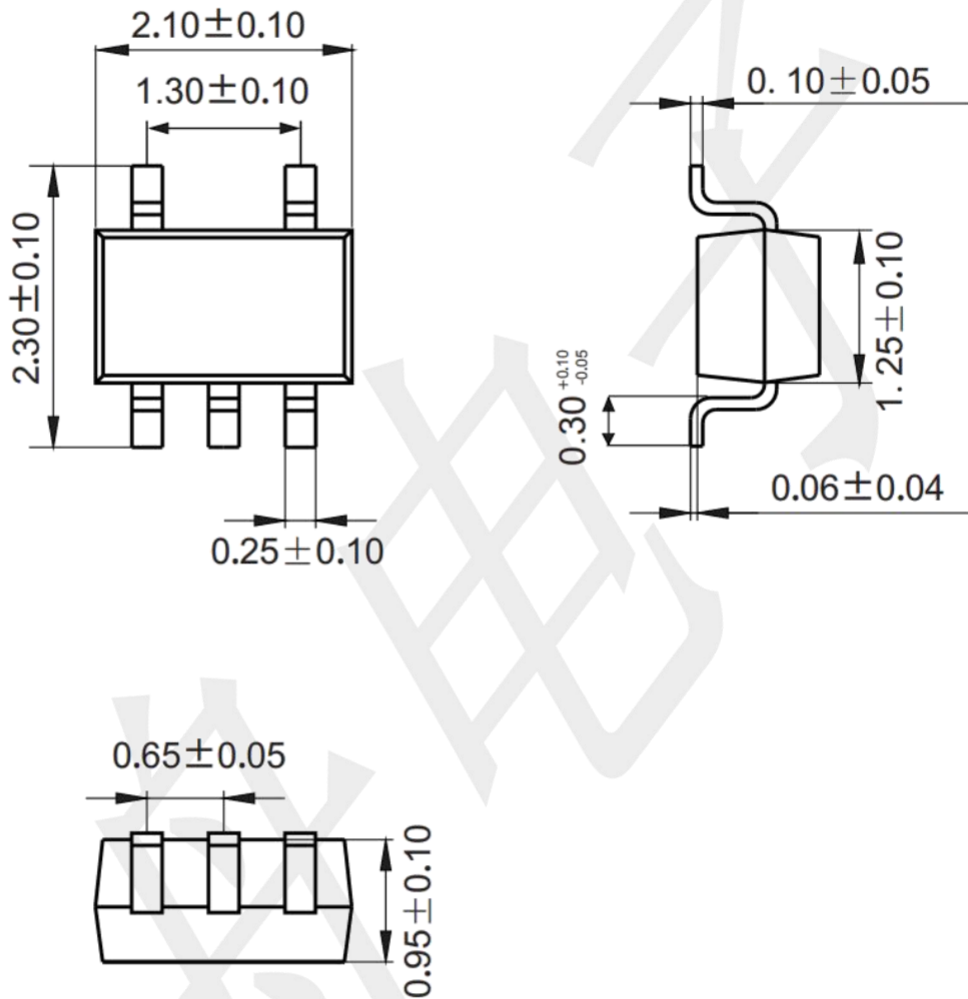

Mounting Pad Layout (unit: mm)

