



Features

- Up to 97% Efficiency
- Shut-down Current: 2μA
- Load Current: up to 500mA
- Low Voltage Start-up
HX3002-AFHC: 1V
HX3002-AF7C: 2V
- Input Voltage
HX3002-AFHC: 1V to 4.4V
HX3002-AF7C: 2V to 4.4V
- Output Voltage: 2.5V to 5V (up to 5V with Schottky)
- Low Switch On Resistance $R_{DS(ON)}$, Internal Switch: 0.35Ω
- 1.4MHz Fixed Frequency Switching
- Automatic PWM/PFM Mode Switching
- Low Profile SOT-23-6L Package (lead-free packaging is now available)

Description

The HX3002 is high efficiency synchronous, PWM step-up DC/DC converters optimized to provide a high efficient solution to medium power systems. The devices work with a 1.4MHz fixed frequency switching. These features minimize overall solution footprint by allowing the use of tiny, low profile inductors and ceramic capacitors. Automatic PWM/PFM mode switching at light load saves power and improves efficiency.

The HX3002 is capable of supplying an output voltage between 2.5V and 5V, the internal synchronous switch is desired to provide high efficiency without Schottky.

The HX3002 regulators are available in the industry standard SOT-23-6L power packages (or upon request).

Applications

- Digital cameras and MP3
- Palmtop computers / PDAs
- Cellular phones
- Wireless handsets and DSL modems
- PC cards
- Portable media players

Order Information

HX3002 - ① ② ③:

| SYMBOL | DESCRIPTION |
|--------|--|
| ① | Denotes Output Voltage: A : Adjustable Output |
| ② | Denotes Package Type: F: SOT-23-6L |
| ③ | Internal Definition: HC or 7C |

Typical Application Circuit

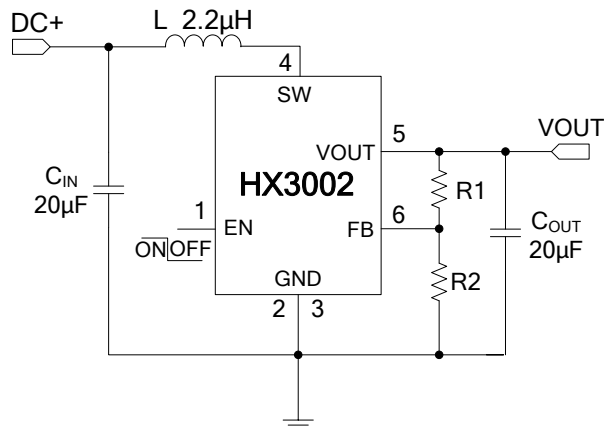

Figure 1: Typical Application Circuit

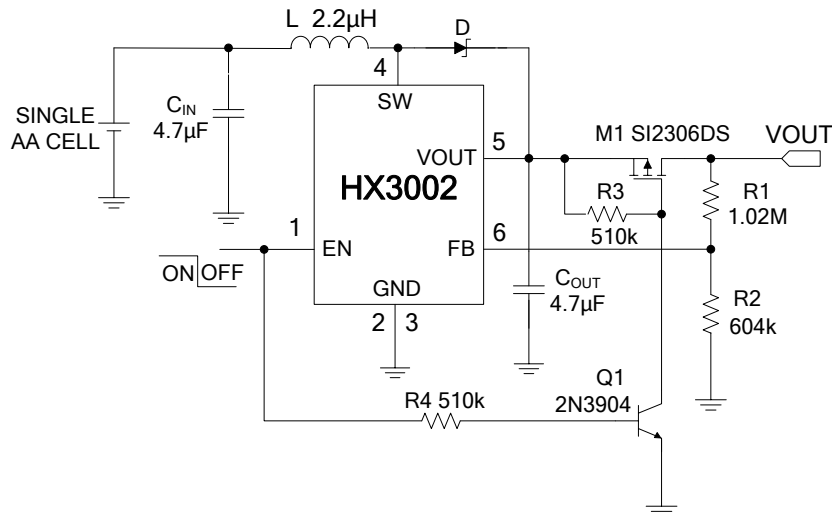

Figure 2: Single Cell to 3.3V Synchronous Boost Converter with Load Disconnect in Shutdown.

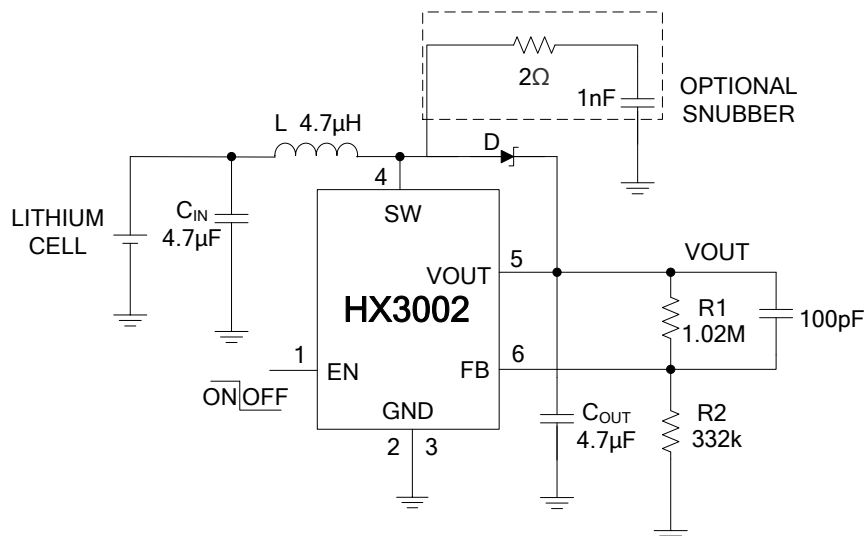

Figure 3: Single Lithium Cell to 5V with Load 250mA

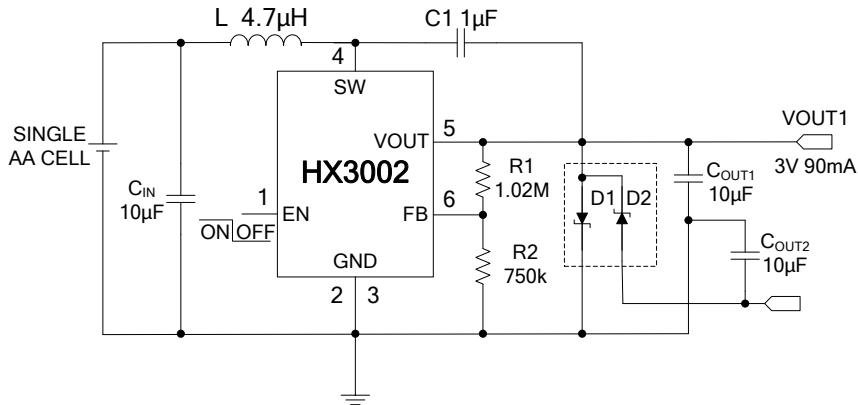

Figure 4: Single Cell AA Cell to ±3V Synchronous Boost Converter

| MODEL | VOUT(V) | VIN(V) | VSTART(V) |
|-------------|---------|---------|-----------|
| HX3002-AFHC | 2.5 ~ 5 | 1 ~ 4.4 | 1 |
| HX3002-AF7C | 2.5 ~ 5 | 2 ~ 4.4 | 2 |

Pin Assignment and Description

| TOP VIEW | | PIN | NAME | DESCRIPTION |
|----------|--|------|------|------------------------------|
| | | 1 | EN | ON/OFF Control (High Enable) |
| | | 2, 3 | GND | Ground |
| | | 4 | SW | Switching Pin |
| | | 5 | VOUT | Output Pin |
| | | 6 | FB | Feedback Input Pin |

Absolute Maximum Ratings (Note 1)

- V_{IN} for HX3002-AFHC.....-0.3V ~ 4.5V
- V_{IN} for HX3001-AF7C.....-0.3V ~ 5V
- V_{OUT}-0.3V ~ 6.6V
- V_{SW} -0.3V ~ 6.6V
- V_{EN}-0.3V ~ 6.6V
- Operating Temperature Range (Note 2).....-40°C ~ +85°C
- Storage Temperature Range-65°C ~ +150°C
- Junction Temperature.....-40°C ~ +125°C
- Lead Temperature (Soldering 10 sec.)+265°C

Note 1: Stresses listed as the above “Absolute Maximum Ratings” may cause permanent damage to the device. Exposure to absolute maximum rating conditions for extended periods may remain possibility to affect device reliability.

Note 2: The HX3002 are guaranteed to meet performance specifications from 0°C to 70°C. Specifications over the -40°C to 85°C operating temperature range are assured by design, characterization and correlation with statistical process controls.

Electrical Characteristics

Operating Conditions: $T_A=25^{\circ}\text{C}$, $V_{IN}=1.2\text{V}$, $V_{OUT}=3.3\text{V}$, unless otherwise specified.

| SYMBOL | PARAMETER | CONDITIONS | MIN | TYP | MAX | UNITS |
|-------------|--|---|------------------|-------|-------|---------------|
| V_{OUT} | Output Voltage Range (Adj.) | | 2.5 | | 5 | V |
| V_{START} | Minimum Start-up Voltage (Note 3) | $I_{LOAD}=1\text{mA}$ | For HX3002 -AFHC | 1 | 1.3 | V |
| | | | For HX3002 -AF7C | 2 | | V |
| V_{HOLD} | Minimum Operating Voltage | $V_{EN}=V_{IN}$ | | 0.6 | 0.75 | V |
| I_Q | Quiescent Current $I_{LOAD}=0\text{mA}$ | For HX3002-AFHC ($V_{IN}=1.2\text{V}$) | | 260 | | μA |
| | | For HX3002-AF7C ($V_{IN}=2.5\text{V}$) | | 500 | | μA |
| I_{SHDN} | Shutdown Current | $V_{EN}=0\text{V}$, Including Switch Leakage | | 0.1 | 1 | μA |
| V_{FB} | Feedback Voltage | For HX3002-AFHC | 1.20 | 1.23 | 1.26 | V |
| | | For HX3002-AF7C | 1.165 | 1.212 | 1.241 | V |
| I_{FB} | Feedback Input Current | $V_{FB}=1.22\text{V}$ | | 1 | | nA |
| f_{OSC} | Switching Frequency | | 1.1 | 1.4 | 1.7 | MHz |
| DC | Max Duty Cycle | $V_{FB}=1.15\text{V}$ | 80 | 87 | | % |
| V_{ENH} | En Input High | | 1 | | | V |
| V_{ENL} | En Input Low | | | | 0.5 | V |
| I_{EN} | En Input Current | $V_{EN}=5.5\text{V}$ | | 0.01 | 1 | μA |
| I_{LIM-N} | NMOS Current Limit | | 700 | 850 | | mA |
| I_{LK-N} | NMOS Switch Leakage | $V_{SW}=5\text{V}$ | | 0.1 | 5 | μA |
| I_{LK-P} | PMOS Switch Leakage | $V_{SW}=0\text{V}$ | | 0.1 | 5 | μA |
| R_{NFET} | NMOS Switch On Resistance | $V_{OUT}=3.3\text{V}$ | | 0.35 | | Ω |
| R_{PFET} | PMOS Switch On Resistance | $V_{OUT}=3.3\text{V}$ | | 0.45 | | Ω |

Note 3: Minimum V_{IN} operation after start-up is only limited by the battery's ability to provide the necessary power as

it enters a deeply discharged state.

Typical Performance Characteristics

Pin Functions

EN (Pin 1): Logic Controlled Shutdown Input. EN = High: Normal free running operation, 1.4MHz typical operating frequency. EN = Low: Shutdown, quiescent current 2 μ A. Output capacitor can be completely discharged through the load or feedback resistors.

GND (Pin 2, 3): Signal and Power Ground. Provide a short direct PCB path between GND and the (-) side of the output capacitor(s).

SW (Pin 4): Switch Pin. Connect inductor between SW and V_{IN} . Keep these PCB trace lengths as short and wide as possible to reduce EMI and voltage overshoot.

VOUT (Pin 5): Output Voltage Pin. PCB trace length from V_{ST} to the output filter capacitor(s) should be as short and wide as possible.

FB (Pin 6): Feedback Input to the g_m Error Amplifier. Connect resistor divider tap to this pin. The output voltage can be adjusted from 2.5V to 5V by: $V_{OUT} = V_{FB} \cdot [1 + (R1/R2)]$.

Applications Information

Inductor Selection

The HX3002 can utilize small surface mount and chip inductors due to their fast 1.4MHz switching frequency. A minimum inductance value of 2.2 μ H is necessary for 3.6V and lower voltage applications and 4.7 μ H for output voltages greater than 3.6V. Larger values by reducing the inductor ripple current. Increasing the inductance above 10 μ H will increase size while providing little improvement in output current capability.

The inductor current ripple is typically set for 20% to 40% of the maximum inductor current (I_P). High frequency ferrite core inductor materials reduce frequency dependent power losses compared to cheaper powdered iron types, improving efficiency. The inductor should have low ESR (series resistance of the windings) to reduce the I^2R power losses, and must be able to handle the peak inductor current without saturating. Molded chokes and some chip inductors usually do not have enough core to support the peak inductor currents of 850mA seen on the HX3002. To minimize radiated noise, use a toroid, pot core or shielded bobbin inductor. See Table 1 for some suggested components and suppliers.

Output and Input Capacitor Selection

Low ESR (equivalent series resistance) capacitors should be used to minimize the output voltage ripple. Multilayer ceramic capacitors are an excellent choice as they have extremely low ESR and are available in small footprints. A 4.7 μ F to 15 μ F output capacitor is sufficient for most applications. Larger values up to 22 μ F may be used to obtain extremely low output voltage ripple and improve transient response. An additional phase lead capacitor may be required with output capacitors larger than 10 μ F to maintain acceptable phase margin. X5R and X7R dielectric materials are preferred for their ability to maintain capacitance over wide voltage and temperature ranges.

Low ESR input capacitors reduce input switching noise and reduce the peak current drawn from the battery. It follows that ceramic capacitors are also a good choice for input decoupling and should be located as close as possible to the device. A 10 μ F input capacitor is sufficient for virtually any application. Larger values may be used without limitations.

Table 1: Suggested Inductors

| Vendor | Part | Inductance (μH) | MAM DCR (mΩ) | Height (mm) |
|---|---------------|-----------------|--------------|-------------|
| Sumida (847)956-0666 www.sumida.com | CDRH5D18-4R1 | 4.1 | 57 | 2.0 |
| | CDRH5D18-100 | 10 | 124 | 2.0 |
| | CDRH3D16-4R7 | 4.7 | 105 | 1.8 |
| | CDRH3D16-6R8 | 6.8 | 170 | 1.8 |
| | CR43-4R7 | 4.7 | 109 | 3.5 |
| | CR43-100 | 10 | 182 | 3.5 |
| | CMD4D06-4R7MC | 4.7 | 216 | 0.8 |
| | CMD4D06-3R3MC | 3.3 | 174 | 0.8 |
| Coilcraft (847)639-6400 www.coilcraft.com | DS1608-472 | 4.7 | 60 | 2.9 |
| | DS1608-103 | 10 | 75 | 2.9 |
| | DS1608C-472 | 4.7 | 90 | 2.9 |
| Toko (408)432-8282 www.takoam.com | D52LC-4R7M | 4.7 | 84 | 2.0 |
| | D52LC-100M | 10 | 137 | 2.0 |
| Murata www.murata.com | LQH3C4R7M24 | 4.7 | 195 | 2.2 |

PCB Layout Guidelines

The high speed operation of the HX3002 demands careful attention to board layout. You will not get advertised performance with careless layout. A large ground pin copper area will help to lower the chip temperature. A multilayer board with a separate ground plane is ideal, but not absolutely necessary.

Recommended component placement: traces carrying high current are direct. Trace area at FB pin is small. Lead length to battery is short.

Packaging Information

SOT-23-6L Surface Mount Package

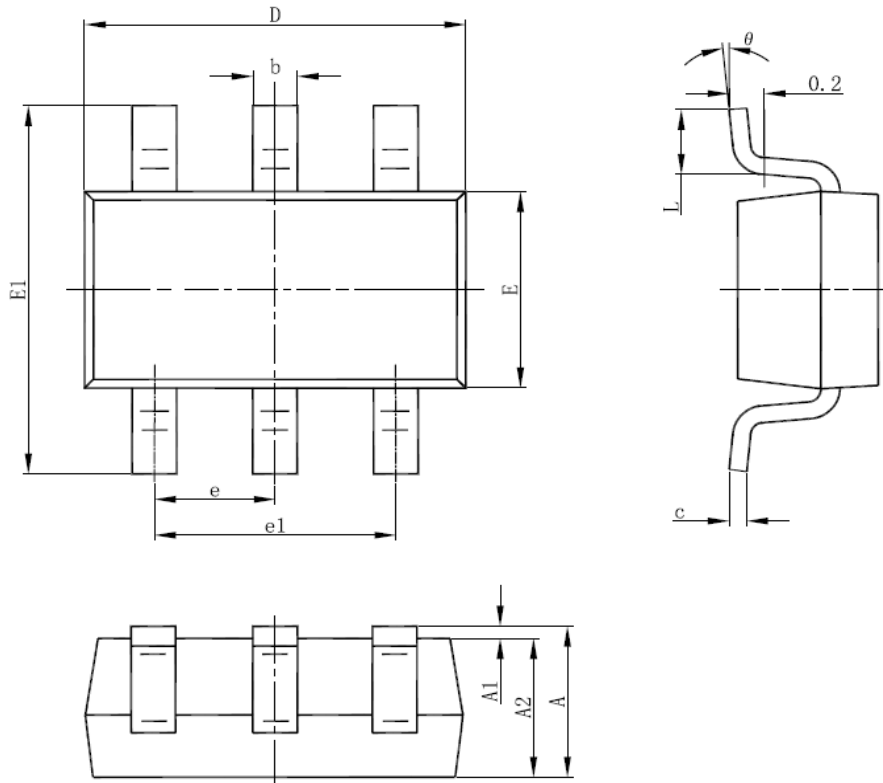

| Symbol | Dimensions In Millimeters | | Dimensions In Inches | |
|----------|---------------------------|-------|----------------------|-------|
| | Min | Max | Min | Max |
| A | 1.050 | 1.250 | 0.041 | 0.049 |
| A1 | 0.000 | 0.100 | 0.000 | 0.004 |
| A2 | 1.050 | 1.150 | 0.041 | 0.045 |
| b | 0.300 | 0.500 | 0.012 | 0.020 |
| c | 0.100 | 0.200 | 0.004 | 0.008 |
| D | 2.820 | 3.020 | 0.111 | 0.119 |
| E | 1.500 | 1.700 | 0.059 | 0.067 |
| E1 | 2.650 | 2.950 | 0.104 | 0.116 |
| e | 0.950(BSC) | | 0.037(BSC) | |
| e1 | 1.800 | 2.000 | 0.071 | 0.079 |
| L | 0.300 | 0.600 | 0.012 | 0.024 |
| θ | 0° | 8° | 0° | 8° |

Subject changes without notice.