



产品承认书 SPECIFICATION FOR APPROVAL

客户名称:

CUSTOMER

我司料号:

OUR PART NO.

XRSQ2418-12mH-H-21225

我司品名:

OUR PART NAME

工字电感

送样日期:

DATE SAMPLES

数量:

QUANTITY

0PCS

制造确认 MANUFACTURER APPROVE

拟制 DRAWN	审核 CHECKED	确认 APPROVED

客户确认 CUSTOMER APPROVE

客户名称 CUSTOMER NAME:

客户料号 CUSTOMER P/N:

规格型号 DESCRIPTION:

SQ2418卧式 12mH 21*22.5脚距

检查结果: 合格 不合格

签名及盖章:

INSPECT RESULT ACCEPT REJECT

SIGNATURE AND STAMP

说明 REMARK:

如对本承认书内容有异议请提出或标记发送至我司, 本承认书在未收到异议回复时于本承认书提供一周后生效。

东莞市祥如电子有限公司

地址: 广东省东莞市塘厦镇莲湖第一工业区南二横路36号B栋

电话: 0769-86346548 传真: 0769-86346358

邮箱: dgxiangru@126.com



东莞市祥如电子有限公司

SPECIFICATION FOR APPROVAL

CUSTOMER _____

CUSTOMER 'S PART NO _____

VER _____

A1

DESCRIPTION _____

SQ2418 卧式 12mH 21*22.5 脚距

OUR DRAWING NO _____

XRSQ2418-12mH-H-21225

A REVISION HISTORY

DATE OF	REVISED PROJECT	EDITION	NOTE
2024/06/05	NEW VERSION	A	

Page2/7

PPROVED BY	CHECKED BY	PREPARED BY	UNIT	mm
李振雄	唐文	谢诗珍	DATE	2024/06/05
			REV NO.	A1



东莞市祥如电子有限公司

SPECIFICATION FOR APPROVAL

CUSTOMER _____

CUSTOMER 'S PART NO _____

VER _____

A1

DESCRIPTION _____

SQ2418 卧式 12mH 21*22.5 脚距

OUR DRAWING NO _____

XRSQ2418-12mH-H-21225

1. APPEARANCE & DIMENSION (UNIT: mm):

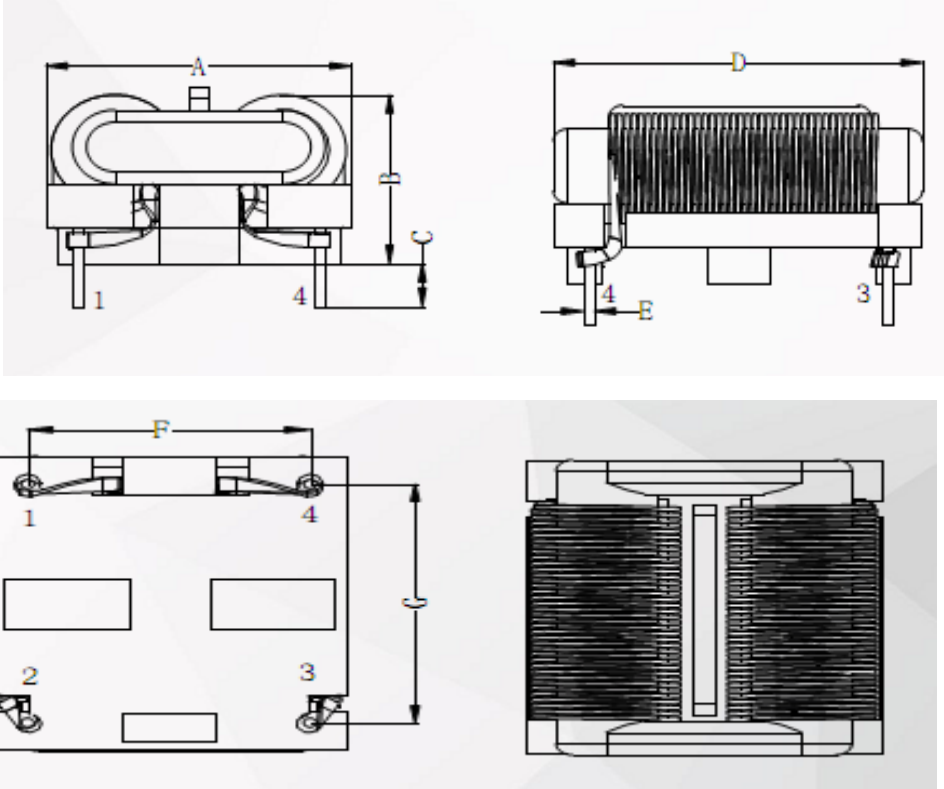

A	B	C	D	E	F	G	H
24MAX	16MAX	3.5MAX	27REF	0.8±0.1	21±0.5	22.5±0.5	

NOTE: 1. 产品共模绕制。 2. 产品需含浸凡立水固定。

Page3/7

PPROVED BY	CHECKED BY	PREPARED BY	UNIT	mm
李振雄	唐文	谢诗珍	DATE	2024/06/05
			REV NO.	A1



东莞市祥如电子有限公司

SPECIFICATION FOR APPROVAL

CUSTOMER _____

CUSTOMER 'S PART NO _____

VER _____

A1

DESCRIPTION _____

SQ2418 卧式 12mH 21*22.5 脚距

OUR DRAWING NO _____

XRSQ2418-12mH-H-21225

2. SCHEMATIC:

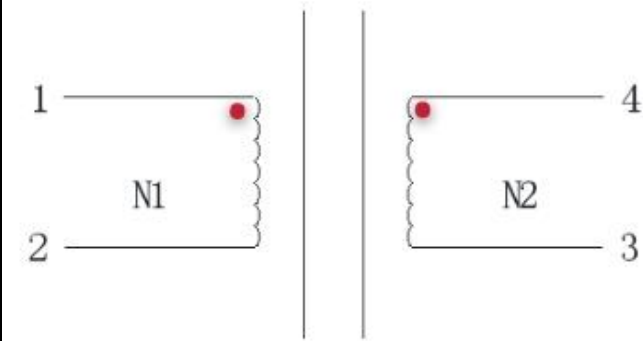

3. WINDING SEQUENCE:

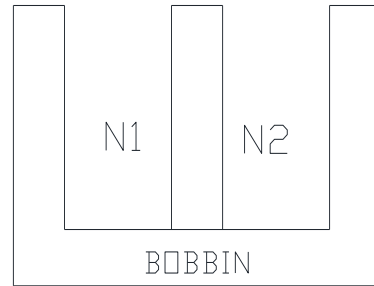

4. WINDING TABLE

ORDER	WIRE SIZE	START	END	TURNS	LAYER	INSULATION	
N1	0.2t×1.5mm UEWH 扁平线	1	2	58TS	CLOSE		
N2	0.2t×1.5mm UEWH 扁平线	4	3	58TS	CLOSE		

Page4/7

PPROVED BY	CHECKED BY	PREPARED BY	UNIT	mm
李振雄	唐文	谢诗珍	DATE	2024/06/05
			REV NO.	A1



东莞市祥如电子有限公司

SPECIFICATION FOR APPROVAL

CUSTOMER _____

CUSTOMER 'S PART NO _____

VER _____

A1

DESCRIPTION _____

SQ2418 卧式 12mH 21*22.5 脚距

OUR DRAWING NO _____

XRSQ2418-12mH-H-21225

TEST CONDITION:		TEMPERATURE AT: 25°C ± 5°C WORKING TEMPERATURE: -25°C/+125°C STORAGE TEMPERATURE: -25°C/+40°C HUMIDITY: AT45-80% RH	
TEST INSTRUMENT	CHENHWA/1062	CHENHWA/1062	CHENHWA/502A
ITEM	INDUCTANCE 1KHz, 0.25Vrms 25°	DIFFERENCE INDUCTANCE 1KHz, 0.25V 25°	DC. RESISTANCE AT 25°C
TERMINAL			
1-2	12mH MIN	0.3mH Max	120mΩ MAX
3-4	12mH MIN	0.3mH Max	120mΩ MAX
TEST INSTRUMENT	E-SUN 19053	E-SUN/19053	
ITEM	HI-POT TEST AC50/60Hz, 5mA, 3sec	INSULATION RESISTANCE. DC 500V	
TERMINAL			
COIL-COIL	1500V	100M Ω MIN	
COIL-CORE	1000V	100M Ω MIN	
I _{rms}	4.5A		

PPROVED BY	CHECKED BY	PREPARED BY	UNIT	mm
李振雄	唐文	谢诗珍	DATE	2024/06/05
			REV NO.	A1



东莞市祥如电子有限公司

SPECIFICATION FOR APPROVAL

CUSTOMER

CUSTOMER 'S PART NO

VER

A1

DESCRIPTION

SQ2418 卧式 12mH 21*22.5 脚距

OUR DRAWING NO

XRSQ2418-12mH-H-21225

6. MATERIAL LIST:

No	ITEM	MATERIAL	CLASS	UL NO.	MANUFACTURER	OPT.
1	CORE	SQ2418 12K			ACMEElectronics (Guangzhou) Co;Ltd	√
		SQ2418 12K			SHANGDONG hengrui magnet technology CO.,LTD	√
		SQ2418 12K			DongGuan City JiuXin Magnetic Material Co.,Ltd	√
		SQ2418 12K			TengZhou MingJi Magnetism Industry Co., Ltd.	√
2	BOBBIN	T375HF	150°C	E59481	CHANG CHUN PLASTICS CO LTD	√
3	WIRE	@* FIWx180	180°C	E234867	SUNTEK HOLDINGS LIMITED	√
		@* UEW180	180°C	E504985	Guangdong Lizewire Electric Technology Co Ltd	√
4	VARNISH	E962	130°C	E335405	ZHUHAI CHANGXIAN NEW MATERIALS TECHNOLOGY CO LTD	√
5	锡	无铅锡条 /Sn99.9			Dongguan City Thousand Island METAL Foil CO LTD	√

Page6/7

PPROVED BY	CHECKED BY	PREPARED BY	UNIT	mm
李振雄	唐文	谢诗珍	DATE	2024/06/05
			REV NO.	A1

