

1. DESCRIPTION

The XL82C250 and XD82C250 are CAN controller interface chips. As a CAN transceiver, The devices provide transmit and receive capability between the differential CAN bus and a CAN controller, with signaling rates up to 1 Mbps.

2. FEATURES

- Fully compatible with the “ISO 11898” standard
- Slope control to reduce Radio Frequency Interference (RFI)
- Short-circuit proof to battery and ground in 12 V powered systems
- Low-current Standby mode
- An unpowered node does not disturb the bus lines
- CAN bus communication speed up to 1 Mbps
- High immunity against electromagnetic interference
- Thermally protected
- Package option: XL82C250 (SOP8), XD82C250 (DIP8)

3. TYPICAL APPLICATION

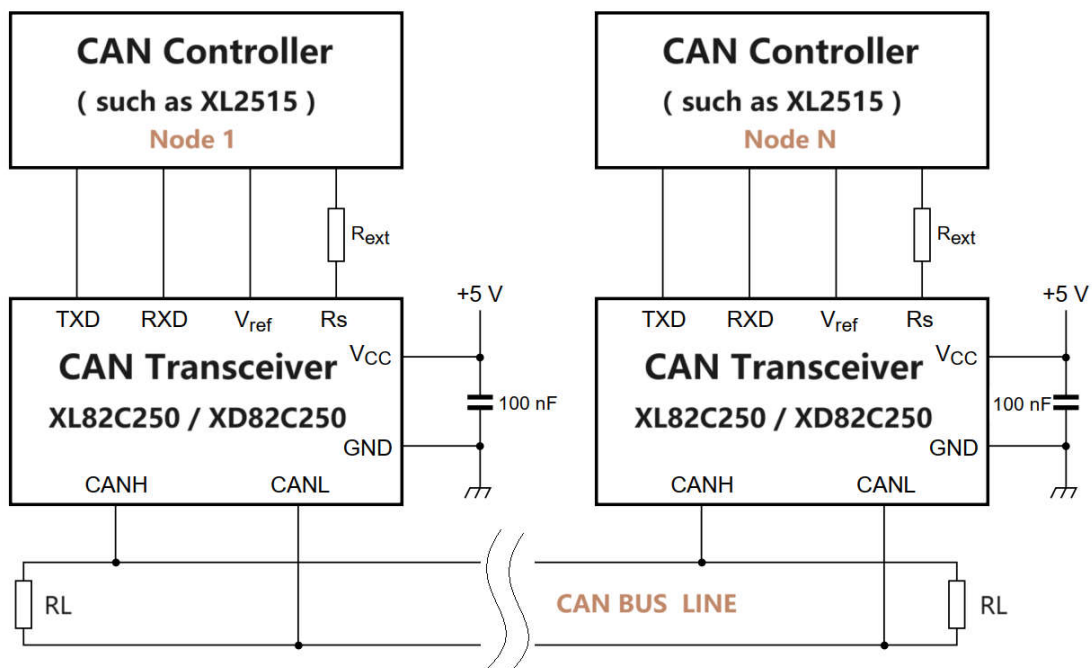

4. PIN CONFIGURATIONS AND FUNCTIONS

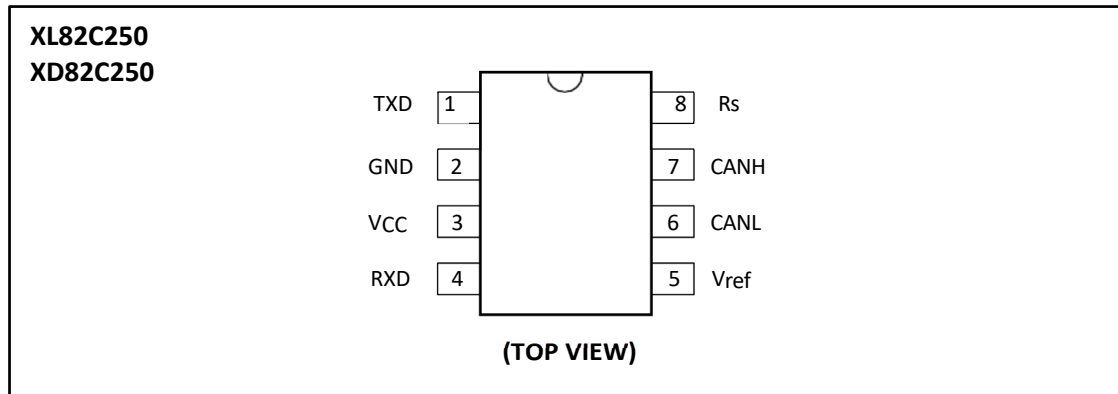

Pin Functions

Symbol	Pin	Description
TXD	1	transmit data input
GND	2	ground
VCC	3	supply voltage
RXD	4	receive data output
Vref	5	reference voltage output
CANL	6	LOW-level CAN voltage input/output
CANH	7	HIGH-level CAN voltage input/output
Rs	8	slope resistor input

4.1. Functional description

The XL82C250 and XD82C250 are the interface between a CAN protocol controller and the physical bus. It is primarily intended for applications up to 1 MBd in trucks and buses. The device provides differential transmit capability to the bus and differential receive capability to the CAN controller. It is fully compatible with the “ISO 11898” standard.

A current-limiting circuit protects the transmitter output stage against short-circuits to positive and negative battery voltage. Although power dissipation will increase as a result of a short circuit fault condition, this feature will prevent destruction of the transmitter output stage.

If the junction temperature exceeds approximately 150 °C, the limiting current of both transmitter outputs is decreased. Because the transmitter is responsible for most of the power dissipated, this will result in reduced power dissipation and hence a lower chip temperature. All other parts of the IC will remain operational. The thermal protection is needed, in particular, when a bus line is short-circuited.

The CANH and CANL lines are also protected against electrical transients which may occur in an automotive environment.

Pin 8 (Rs) allows three different modes of operation to be selected: High-speed, Slope control and Standby.

For high-speed operation, the transmitter output transistors are simply switched on and off as fast as possible. In this mode, no measures are taken to limit the rise and fall slopes. A shielded cable is recommended to avoid RFI problems. High-speed mode is selected by connecting pin 8 to ground.

Slope control mode allows the use of an unshielded twisted pair or a parallel pair of wires as bus lines. To reduce RFI, the rise and fall slopes should be limited. The rise and fall slopes can be programmed with a resistor connected from pin 8 to ground. The slope is proportional to the current output at pin 8.

If a HIGH level is applied to pin 8, the circuit enters a low-current Standby mode. In this mode, the transmitter is switched off and the receiver is switched to a low current. If dominant bits are detected (differential bus voltage >0.9 V), RXD will be switched to a LOW level. The microcontroller should react to this condition by switching the transceiver back to normal operation (via pin 8). Because the receiver is slower in Standby mode, the first message will be lost at higher bit rates.

Table 4-1. Truth table of the CAN transceiver

Supply	TXD	CANH	CANL	Bus state	RXD
4.5 V to 5.5 V	0	HIGH	LOW	dominant	0
4.5 V to 5.5 V	1 (or floating)	floating	floating	recessive	1
<2V (not powered)	X ^[1]	floating	floating	recessive	X ^[1]
2 V < V _{CC} < 4.5 V	>0.75 V _{CC}	floating	floating	recessive	X ^[1]
2 V < V _{CC} < 4.5 V	X ^[1]	floating if V _{Rs} > 0.75V _{CC}	Floating If V _{Rs} > 0.75V _{CC}	recessive	X ^[1]

[1] X = don't care.

Table 4-2. Pin Rs summary

Condition forced at pin Rs	Mode	Resulting voltage or current at pin Rs
V _{Rs} > 0.75V _{CC}	Standby	I _{Rs} < 10 μA
-10 μA < I _{Rs} < -200 μA	Slope control	0.4V _{CC} < V _{Rs} < 0.6V _{CC}
V _{Rs} < 0.3V _{CC}	High-speed	I _{Rs} < -500 μA

5. BLOCK DIAGRAM

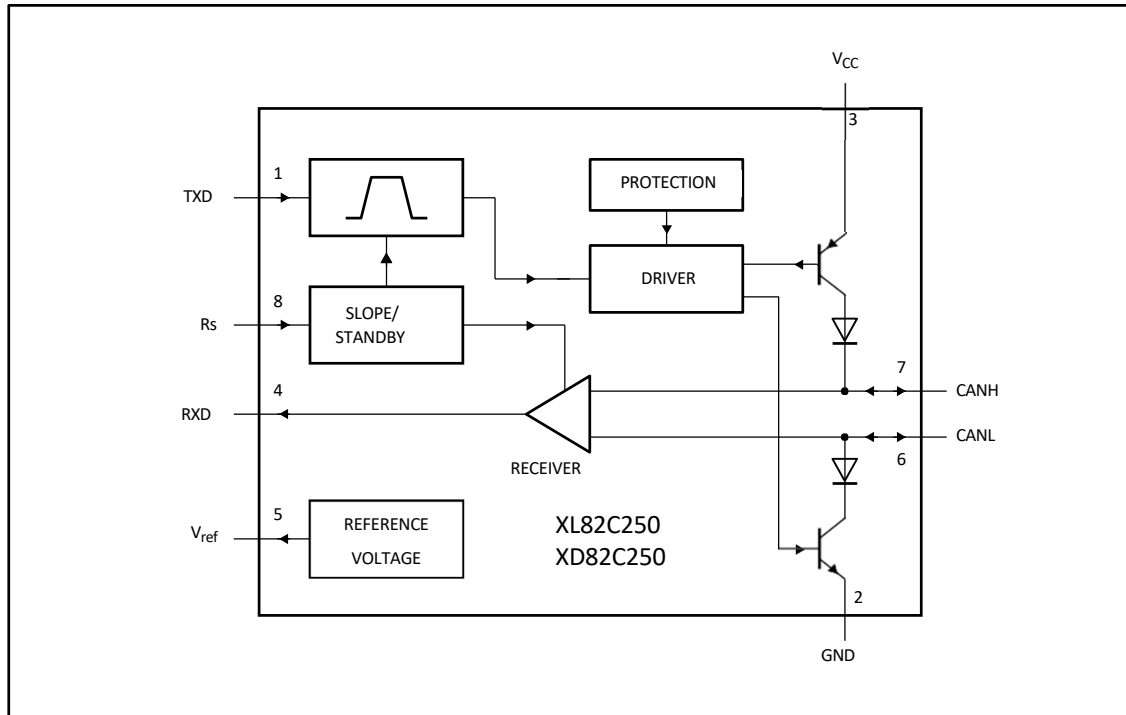

Fig 5-1. Block Diagram

6. SPECIFICATIONS

6.1 Absolute Maximum Ratings

In accordance with the Absolute Maximum Rating System (IEC 60134). All voltages are referenced to pin 2 (GND) ; positive input current.

Symbol	Parameter	Conditions	Min	Max	Unit
VCC	supply voltage		- 0.3	+7.0	V
Vn	DC voltage at pins 1, 4, 5 and 8		- 0.3	V _{CC} + 0.3	V
V6,7	DC voltage at pin 6 and 7	0 V < V _{CC} < 5.5 V; no time limit	-8	+18	V
Vtrt	transient voltage at pins 6 and 7	see Figure 6-6	- 150	+100	V
Tstg	storage temperature		- 50	+150	°C
Tamb	ambient temperature		- 40	+85	°C
Tvj	virtual junction temperature	[2]	- 40	+150	°C
VESD	electrostatic discharge voltage	[3]	- 2000	+2000	V
		[4]	- 150	+150	V

- [1] Stresses beyond those listed under Absolute Maximum Ratings may cause permanent damage to the device. These are stress ratings only, and functional operation of the device at these or any other conditions beyond those indicated under Recommended Operating Conditions is not implied. Exposure to absolute-maximum-rated conditions for extended periods may affect device reliability.
- [2] An alternative definition of virtual junction temperature is: $T_{vj} = T_{amb} + P_d \times R_{th(j-a)}$, where $R_{th(j-a)}$ is a fixed value to be used for the calculation of T_{vj} . The rating for T_{vj} limits the allowable combinations of power dissipation (P_d) and ambient temperature (T_{amb}).
- [3] Classification A: human body model; C = 100 pF; R = 1500 Ω; V = ±2000 V.
- [4] Classification B: machine model; C = 200 pF; R = 25 Ω; V = ±150 V.

6.2 Recommended Operating Conditions

Symbol	Parameter	Conditions	Min	Max	Unit
VCC	supply voltage		4.5	5.5	V
ICC	supply current	Standby mode	-	210	μA
1/tbit	maximum transmission speed	non-return-to-zero	-	1	MBd
VCAN	CANH, CANL input/output voltage		-8	+18	V
Vdiff	differential bus voltage		1.5	3.0	V
tPD	propagation delay	High-speed mode	-	60	ns
Tamb	ambient temperature		-40	+85	°C

6.3 Thermal Data

Symbol	Parameter	Conditions	Typ	Unit
Rth(j-a)	thermal resistance from junction to ambient	in free air	165	K/W

6.4 Characteristics

VCC = 4.5 V to 5.5 V; Tamb = -40° C to +85° C; RL = 60 Ω; I8 > -10 μA; unless otherwise specified; all voltages referenced to ground (pin 2); positive input current; all parameters are guaranteed over the ambient temperature range by design, but only 100 % tested at +25 °C.

Sym.	Parameter	Conditions	Min	Typ	Max	Unit
Power Supply consumption						
I3	Supply current	Dominant; V ₁ = 1 V	-	-	75	mA
		Recessive; V ₁ = 4 V; R _g = 47 kΩ	-	-	18	mA
		Recessive; V ₁ = 4 V; V ₈ = 1V	-	-	22	mA
		Standby; Tamb < 80° C [1]	-	168	210	μA
DC bus transmitter						
V _{IH}	HIGH-level input voltage	output recessive	0.7V _{CC}	-	V _{CC} + 0.3	V
V _{IL}	LOW-level input voltage	output dominant	-0.3	-	0.3V _{CC}	V
I _{IH}	HIGH-level input current	V ₁ = 4 V	-220	-	+40	μA
I _{IL}	LOW-level input current	V ₁ = 1 V	-110	-	-650	μA
V _{6,7}	recessive bus voltage	V ₁ = 4 V; no load	2.0	-	3.0	V
I _{LO}	off-state output leakage current	2 V < (V ₆ , V ₇) < 7 V	-2	-	+1	mA
		5 V < (V ₆ , V ₇) < 18 V	-5	-	+12	mA
V ₇	CANH output voltage	V ₁ = 1 V	2.75	-	4.5	V
V ₆	CANL output voltage	V ₁ = 1 V	0.5	--	2.25	V
ΔV _{6,7}	difference between output voltage at pins 6 and 7	V ₁ = 1 V	1.5	-	3.0	V
		V ₁ = 1 V; R _L = 45Ω; V _{CC} ≥ 4.9V	1.5	-	-	V
		V ₁ = 4 V; no load	-500	-	+50	mV
I _{sc7}	short-circuit CANH current	V ₇ = -5V ; V _{CC} ≤ 5V	-	-	-120	mA
		V ₇ = -5V ; V _{CC} = 5.5V	-	-	-130	mA
I _{sc6}	short-circuit CANL current	V ₆ = 18 V	-	-	170	mA
DC bus receiver: V₁ = 4 V; pins 6 and 7 externally driven; - 2V < (V₆, V₇) < 7 V; unless otherwise specified						
V _{diff(r)}	differential input voltage (recessive)		-1.0	-	+0.5	V
		7 V < (V ₆ , V ₇) < 12 V, non-Standy mode	-1.0	-	+0.4	V
V _{diff(d)}	differential input voltage (dominant)		0.9	-	5.0	V
		7 V < (V ₆ , V ₇) < 12 V, non-Standy mode	1.0	-	5.0	V
V _{diff(hys)}	differential input hysteresis	see Figure 6-3	-	160	-	mV
VOH	HIGH-level output voltage	pin 4; I ₄ = -100 μA	0.8V _{CC}	-	V _{CC}	V
VOL	LOW-level output voltage	pin 4; I ₄ = 1 mA	0	-	0.2V _{CC}	V
		I ₄ = 10 mA	0	-	1.5	V
R _i	input resistance	CANH, CANL	4.7	-	30	kΩ
R _{diff}	differential input resistance		19.2	-	120	kΩ
C _i	input capacitance	CANH, CANL	-	-	20	pF
C _{diff}	differential input capacitance		-	-	10	pF
Reference output						
V _{ref}	reference output voltage	V ₈ = 1 V; I ₅ < 50 μA	0.45V _{CC}	-	0.55V _{CC}	V
		V ₈ = 4 V; I ₅ < 5 μA	0.4V _{CC}	-	0.6V _{CC}	V
Timing (CL = 100 pF; see Figure 6-1, Figure 6-2, Figure 6-4 and Figure 6-5)						
t _{bit}	minimum bit time	R _s = 0 Ω	-	-	1	μs
tonTXD	delay TXD to bus active	R _s = 0 Ω	-	-	60	ns

[1] I₁ = I₄ = I₅ = 0 mA; 0 V < V₆ < V_{CC}; 0 V < V₇ < V_{CC}; V₈ = V_{CC}

6.4 Characteristics (continued)

Sym.	Parameter	Conditions	Min	Typ	Max	Unit
Timing (CL = 100 pF; see Figure 6-1, Figure 6-2, Figure 6-4 and Figure 6-5)						
toffTXD	delay TXD to bus inactive	$R_s = 0 \Omega$	-	45	90	ns
tonRXD	delay TXD to receiver active	$R_s = 0 \Omega$	-	65	130	ns
toffRXD	delay TXD to receiver inactive	$R_s = 0 \Omega; V_{CC} < 5.1V; T_{amb} < 85^\circ C$	-	90	160	ns
		$R_s = 0 \Omega; V_{CC} < 5.5V; T_{amb} < 85^\circ C$	-	105	180	ns
tonRXD	delay TXD to receiver active	$R_s = 47 k\Omega$	-	400	550	ns
		$R_s = 24 k\Omega$	-	280	350	ns
toffRXD	delay TXD to receiver inactive	$R_s = 47 k\Omega$	-	280	500	ns
		$R_s = 24 k\Omega$	-	230	350	ns
SR	differential output voltage slew rate	$R_s = 47 k\Omega$	-	16	-	V/us
tWAKE	wake-up time from Standby	via pin 8	-	-	25	us
tdRXDL	bus dominant to RXD LOW	$V_8 = 4 V; \text{Standby mode}$	-	-	10	us
Standby/Slope Control (pin 8)						
V_g	input voltage for high-speed		-	-	0.3VCC	V
I_g	input current for high-speed	$V_8 = 0V$	-	-	-500	uA
V_{stb}	input voltage for Standby mode		0.75VCC	-	-	V
I_{slope}	slope control mode current		-10	-	-200	uA
V_{slope}	slope control mode voltage		0.4VCC	-	0.6VCC	V

[1] $I_1 = I_4 = I_5 = 0 \text{ mA}; 0 \text{ V} < V_6 < V_{CC}; 0 \text{ V} < V_7 < V_{CC}; V_8 = V_{CC};$

[2] This is valid for the receiver in all modes: High-speed, Slope control and Standby.

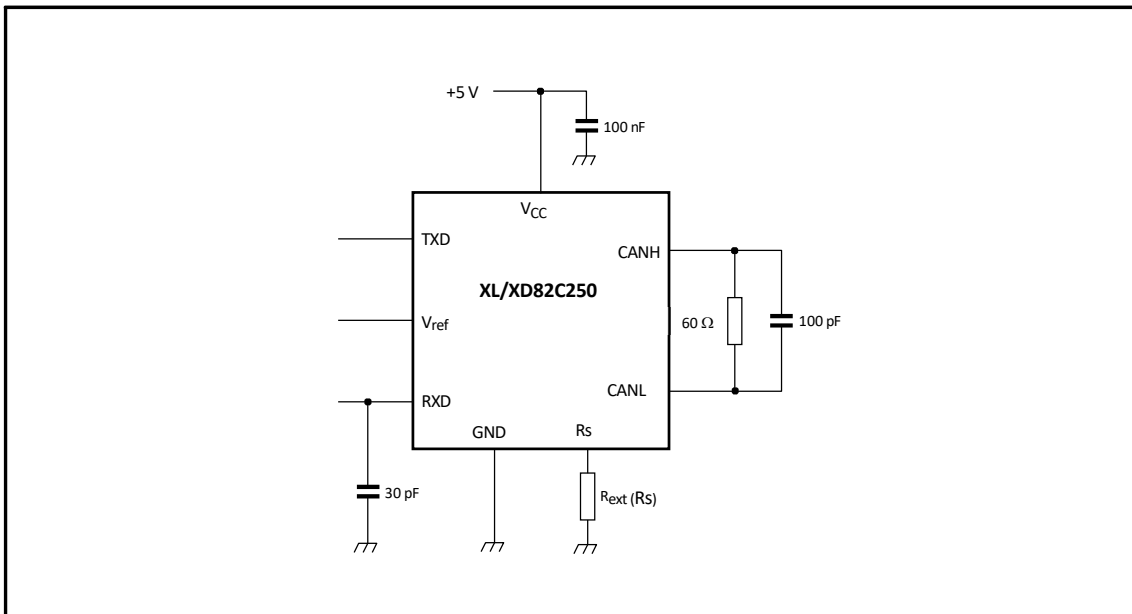
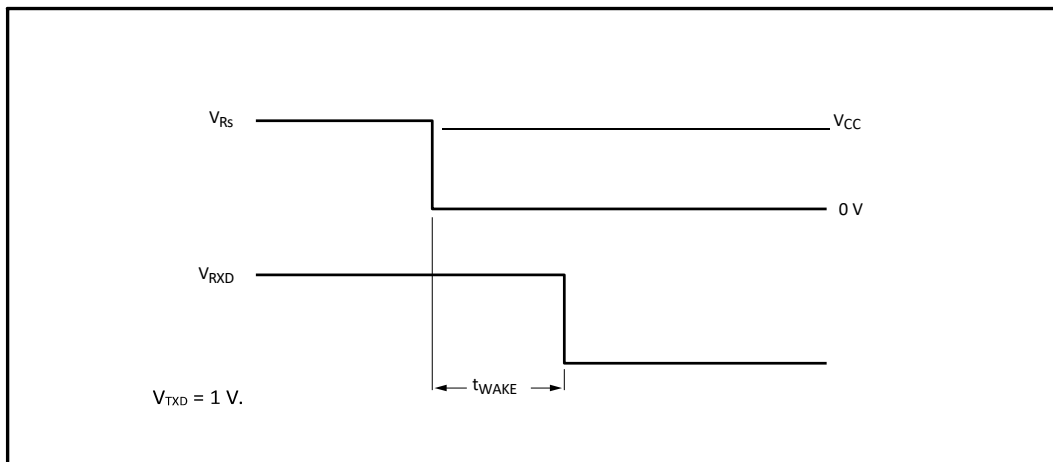
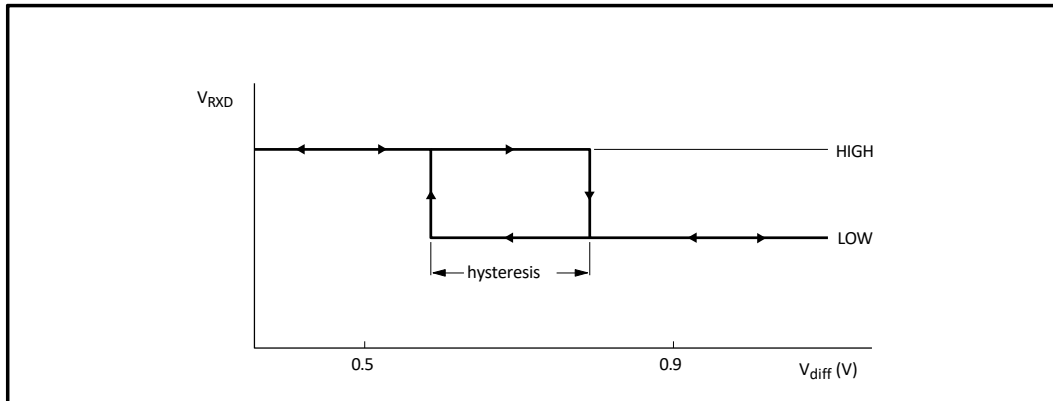
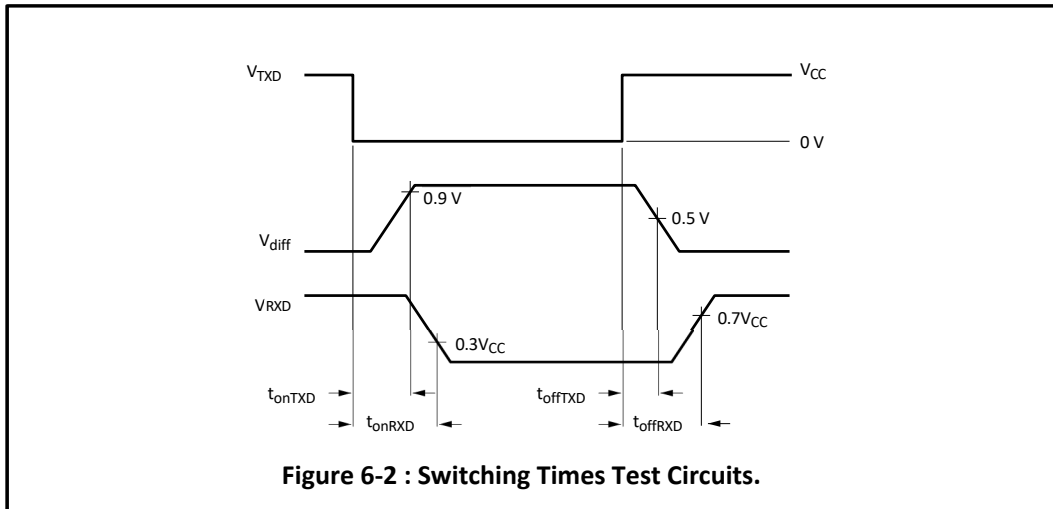

Figure 6-1 : Test circuit for dynamic characteristics



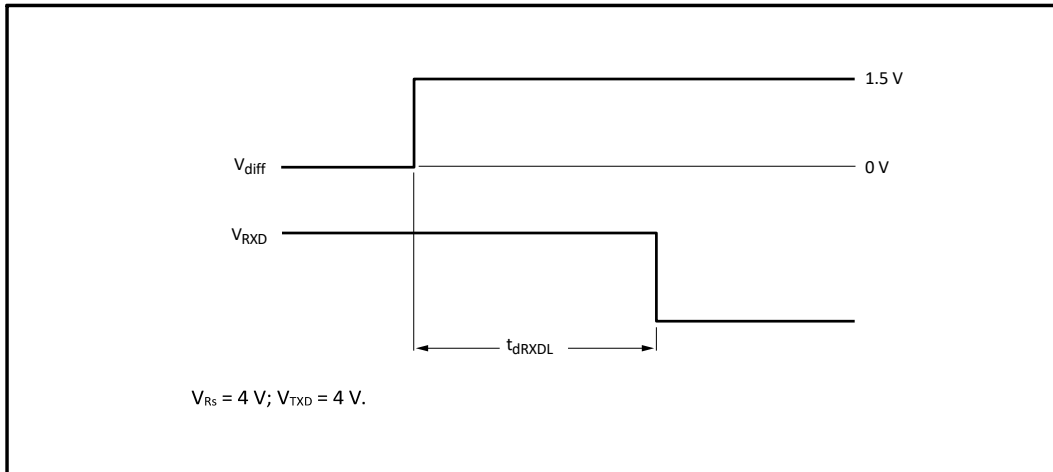

Figure 6-5. Timing diagram for bus dominant to RXD LOW

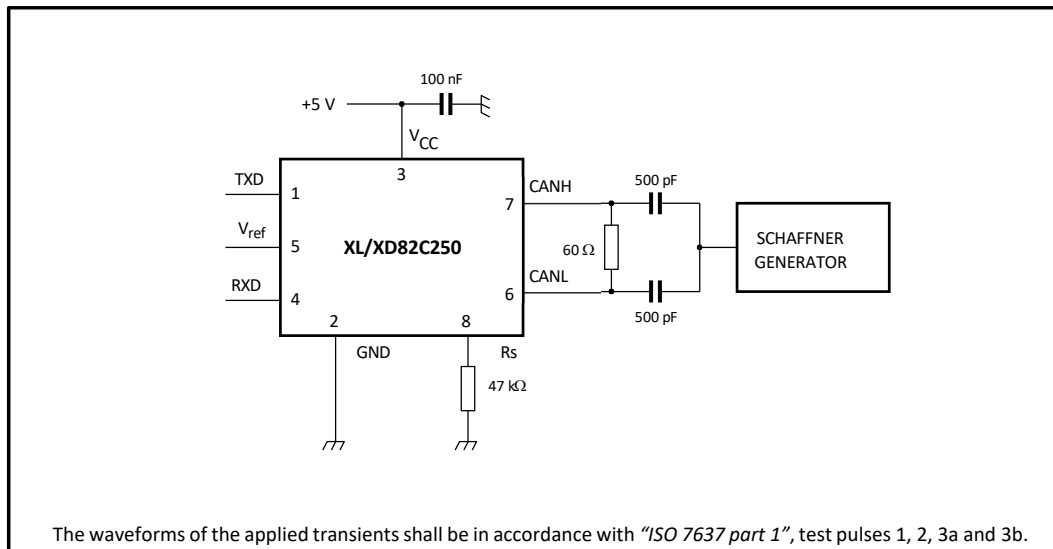

Figure 6-6. Test circuit for transients

7. ORDERING INFORMATION

Ordering Information

Part Number	Device Marking	Package Type	Body size (mm)	Temperature (°C)	MSL	Transport Media	Package Quantity
XL82C250	XL82C250	SOP8	4.90 * 3.90	- 40 to 85	MSL3	T&R	2500
XD82C250	XD82C250	DIP8	9.25 * 6.38	- 40 to 85	MSL3	Tube 50	2000

8. DIMENSIONAL DRAWINGS

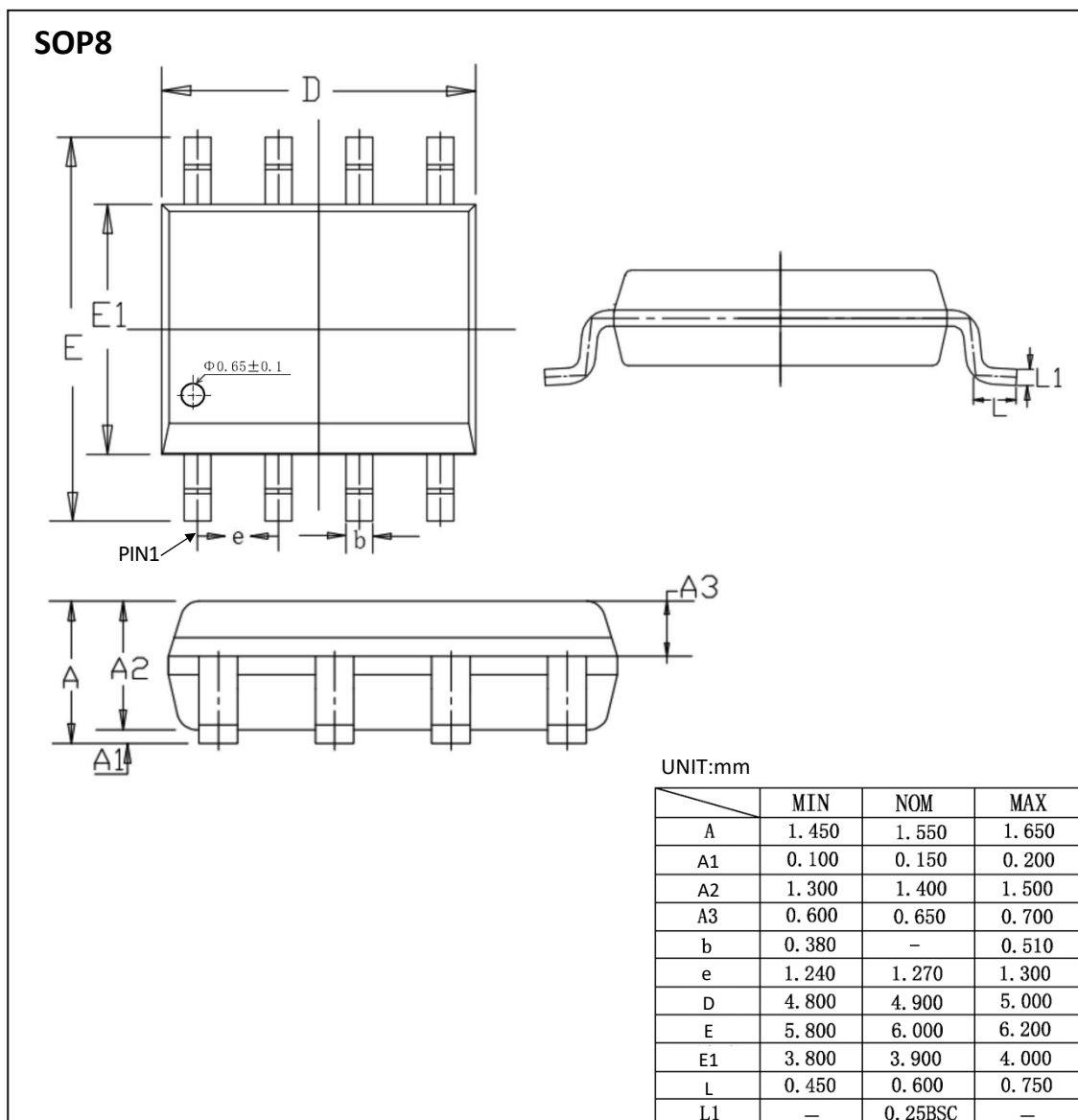

DIP8

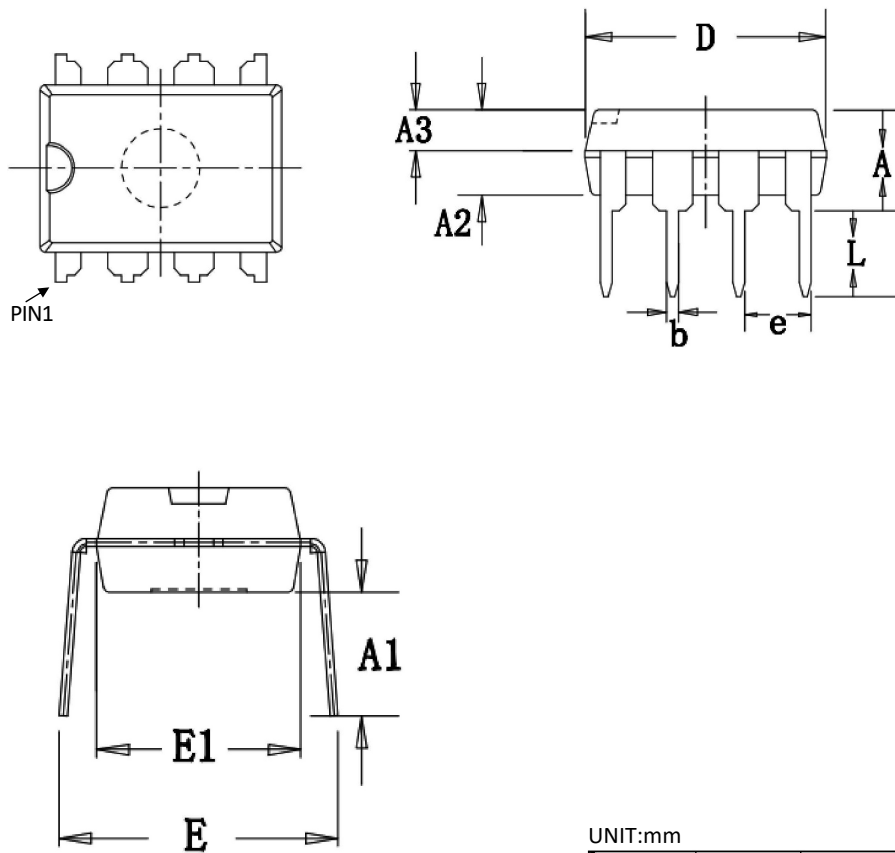

UNIT:mm

	MIN	NOM	MAX
A	3.600	3.800	4.000
A1	3.786	3.886	3.986
A2	3.200	3.300	3.400
A3	1.550	1.600	1.650
b	0.440	—	0.490
e	2.510	2.540	2.570
D	9.150	9.250	9.350
E	7.800	8.500	9.200
E1	6.280	6.380	6.480
L	3.000	—	—

[if you need help contact us. Xinluda reserves the right to change the above information without prior notice]