

DESCRIPTION

- Collector-Emitter Breakdown Voltage-
: $V_{(BR)CEO} = 300V(\text{Min.})$
- Collector-Emitter Saturation Voltage-
: $V_{CE(sat)} = 2.0V(\text{Max.}) @ I_C = 5A$

APPLICATIONS

- Designed for use in automotive ignition, switching and motor control applications.

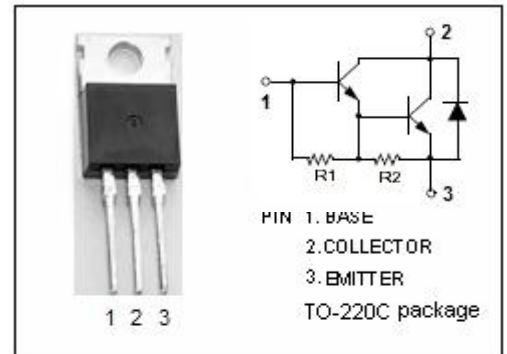

ABSOLUTE MAXIMUM RATINGS($T_a=25^\circ\text{C}$)

SYMBOL	PARAMETER	VALUE	UNIT
V_{CBO}	Collector-Base Voltage	300	V
V_{CEO}	Collector-Emitter Voltage	300	V
V_{EBO}	Emitter-Base Voltage	8	V
I_C	Collector Current-Continuous	7	A
I_{CM}	Collector Current-Peak	10	A
I_B	Base Current- Continuous	1.5	A
P_C	Collector Power Dissipation @ $T_c=25^\circ\text{C}$	80	W
T_j	Junction Temperature	150	$^\circ\text{C}$
T_{stg}	Storage Temperature Range	-65~150	$^\circ\text{C}$

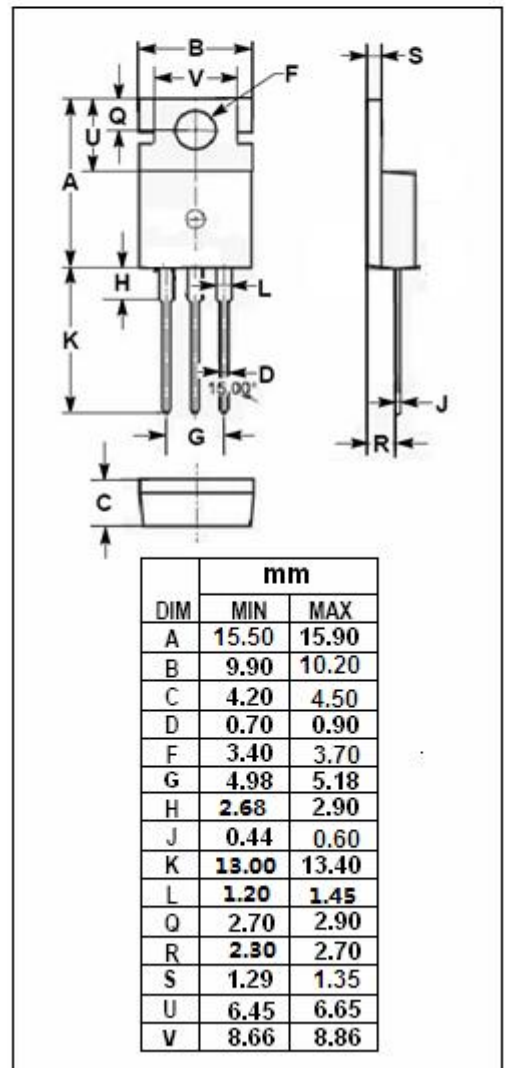

THERMAL CHARACTERISTICS

SYMBOL	PARAMETER	MAX	UNIT
$R_{th\ j-c}$	Thermal Resistance, Junction to Case	1.56	$^\circ\text{C}/\text{W}$

ELECTRICAL CHARACTERISTICS

T_C=25°C unless otherwise specified

SYMBOL	PARAMETER	CONDITIONS	MIN	TYP.	MAX	UNIT
V _{(BR)CEO}	Collector-Emitter Breakdown Voltage	I _C = 10mA, I _B = 0	300			V
V _{(BR)CBO}	Collector-Base Breakdown Voltage	I _C = 1.0mA, I _E = 0	300			V
V _{CE(sat)-1}	Collector-Emitter Saturation Voltage	I _C = 1A, I _B = 10mA			1.5	V
V _{CE(sat)-2}	Collector-Emitter Saturation Voltage	I _C = 2A, I _B = 100mA			1.5	V
V _{CE(sat)-3}	Collector-Emitter Saturation Voltage	I _C = 5A, I _B = 250mA			2.0	V
V _{BE(sat)-1}	Base-Emitter Saturation Voltage	I _C = 2A, I _B = 100mA			2.2	V
V _{BE(sat)-2}	Base-Emitter Saturation Voltage	I _C = 5A, I _B = 250mA			2.3	V
V _F	C-E Diode Forward Voltage	I _F = 7A			3.5	V
I _{CEO}	Collector Cutoff current	V _{CE} = 300V, I _B = 0			0.25	mA
I _{EBO}	Emitter Cutoff Current	V _{EB} = 8V; I _C = 0			15	mA
h _{FE-1}	DC Current Gain	I _C = 2.5A; V _{CE} = 5V	150			
h _{FE-2}	DC Current Gain	I _C = 5A; V _{CE} = 5V	50			
h _{FE-3}	DC Current Gain	I _C = 7A; V _{CE} = 5V	15			
C _{OB}	Collector Output Capacitance	I _E = 0; V _{CB} = 10V; f= 1MHz			150	pF

Switching Times

t _d	Delay Time	V _{CC} = 250V, I _C = 5.0 A, I _{B1} = -I _{B2} = 250mA; t _p = 20 μ s Duty Cycle ≤ 2%		0.03		μ s
t _r	Rise Time			0.18		μ s
t _{stg}	Storage Time			3.5		μ s
t _f	Fall Time			1.6		μ s