

CD4081 Quad 2-Input And Gate

1. General Description

1.1 Description

The CD4081 is a quad 2-input AND gate. These quad gates are monolithic complementary MOS (CMOS) integrated circuits constructed with N- and P-channel enhancement mode transistors. They have equal source and sink current capabilities. The devices also have buffered outputs which improve transfer characteristics by providing very high gain. All inputs are buffered.

1.2 Features

- Wide operating voltage range $V_{DD}=3V$ to $18V$

- Fully static operation
- 5V-10V-15V parametric ratings
- Standardized symmetrical output characteristics
- Inputs and outputs are protected against electrostatic effects
- Specified from $-40^{\circ}C$ to $+85^{\circ}C$

1.3 Ordering Information

PART NUMBER	PACKAGE
CD4081	DIP
	SOP
	TSSOP

2. Connection Diagrams and Pin Description

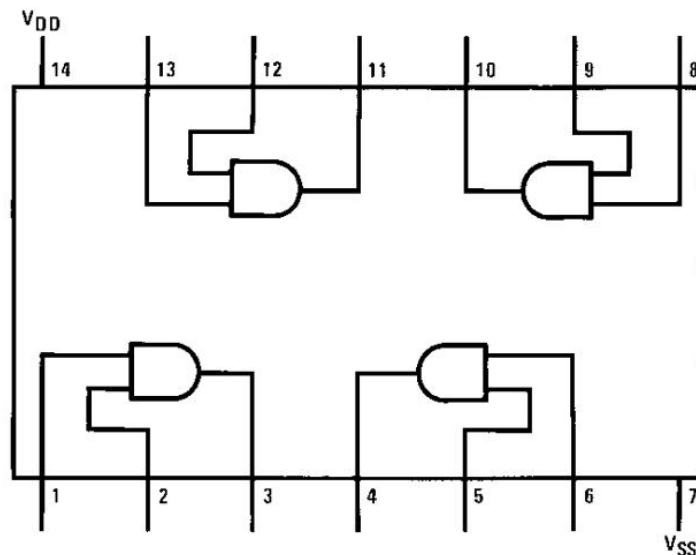

Figure 2.1 Top View

PIN No.	NAME	I/O	FUNCTION
1	1A	I	Data Input
2	1B	I	Data Input
3	1Y	O	Data Output
4	2Y	O	Data Output
5	2A	I	Data Input
6	2B	I	Data Input
7	VSS		Ground
8	3A	I	Data Input
9	3B	I	Data Input
10	3Y	O	Data Output
11	4Y	O	Data Output
12	4A	I	Data Input
13	4B	I	Data Input
14	VDD		Positive Supply Voltage

3. System Diagram

3.1 Logic Diagram

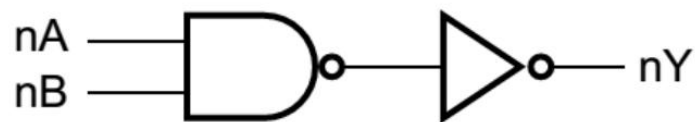

Figure 3.1: CD4081 Logic Diagram (one gate)

3.2 Truth Table

Input		Outputs
nA	nB	nY
0	0	0
0	1	0
1	0	0
1	1	1



4. Specifications

4.1 Absolute Maximum Ratings

Symbol	Parameter	MIN	MAX	Unit
V _{DD}	Supply Voltage	-0.5	20	V
V _I	DC Input Voltage	0.5	V _{CC} +0.5	V
P _D	Power Dissipation		500	mW
T _J	Junction Temperature		125	°C
T _{OP}	Operating Temperature	-40	85	°C

Absolute maximum ratings are those values beyond which the device could be permanently damaged, These are stress ratings only, which do not imply functional operation of the device at these or any other conditions beyond those indicated under Recommended Operating Conditions.

4.2 Electrical Characteristics

(T_a=25°C, voltages are referenced to V_{SS} (ground=0V), unless otherwise specified)

Symbol	Parameter	Test Condition			MIN	TYP	MAX	Unit
		V _O	V _{IN}	V _{DD}				
I _{DD}	Supply Current		0,5	5	--		1	uA
			0,10	10	--		1	uA
			0,18	18	--		2	uA
I _{OL}	Low Level Output Current	0.4	0,5	5	1	2	--	mA
		0.5	0,10	10	2	5	--	mA
		1.5	0,15	15	10	20	--	mA
I _{OH}	High Level Output Current	4.6	0,5	5	-0.5	-1	--	mA
		2.5	0,5	5	-2	-4	--	mA
		9.5	0,10	10	-1	-2.2	--	mA
		13.5	0,15	15	-4	-8	--	mA
V _{OL}	Low Level Output Voltage		0,5	5	--	0.0	0.05	V
			0,10	10	--	0.0	0.05	V
			0,15	15	--	0.0	0.05	V
V _{OH}	High Level Output Voltage		0,5	5	4.95	5	--	V
			0,10	10	9.95	10	--	V
			0,15	15	14.95	15	--	V
V _{IL}	Low Level Output Voltage	0.5,4.5		5	--		1.5	V
		1,9		10	--		3	V
		1.5,13.5		15	--		4	V
V _{IH}	High Level Output Voltage	0.5		5	3.5		--	V
		1		10	7		--	V
		1.5		15	11		--	V
I _I	Input Leakage Current		0,18	18	--		±1	uA



5. Ordering Information

Orderable Device	Package Type	Pins	Packing	Package Qty
CD4081ND14ATBE	DIP	14	Tube	25
CD4081NS14ARDQ	SOP	14	Tape & Reel	4000
CD4081TS14ARBQ	TSSOP	14	Tape & Reel	2000

6. Package Information

6.1 DIP14

DIM.	mm.			inch		
	MIN.	TYP.	MAX.	MIN.	TYP.	MAX.
a1	0.51			0.020		
B	1.39		1.65	0.055		0.065
b		0.5			0.020	
b1		0.25			0.010	
D			20			0.787
E		8.5			0.335	
e		2.54			0.100	
e3		15.24			0.600	
F			7.1			0.280
I			5.1			0.201
L		3.3			0.130	
Z	1.27		2.54	0.050		0.100

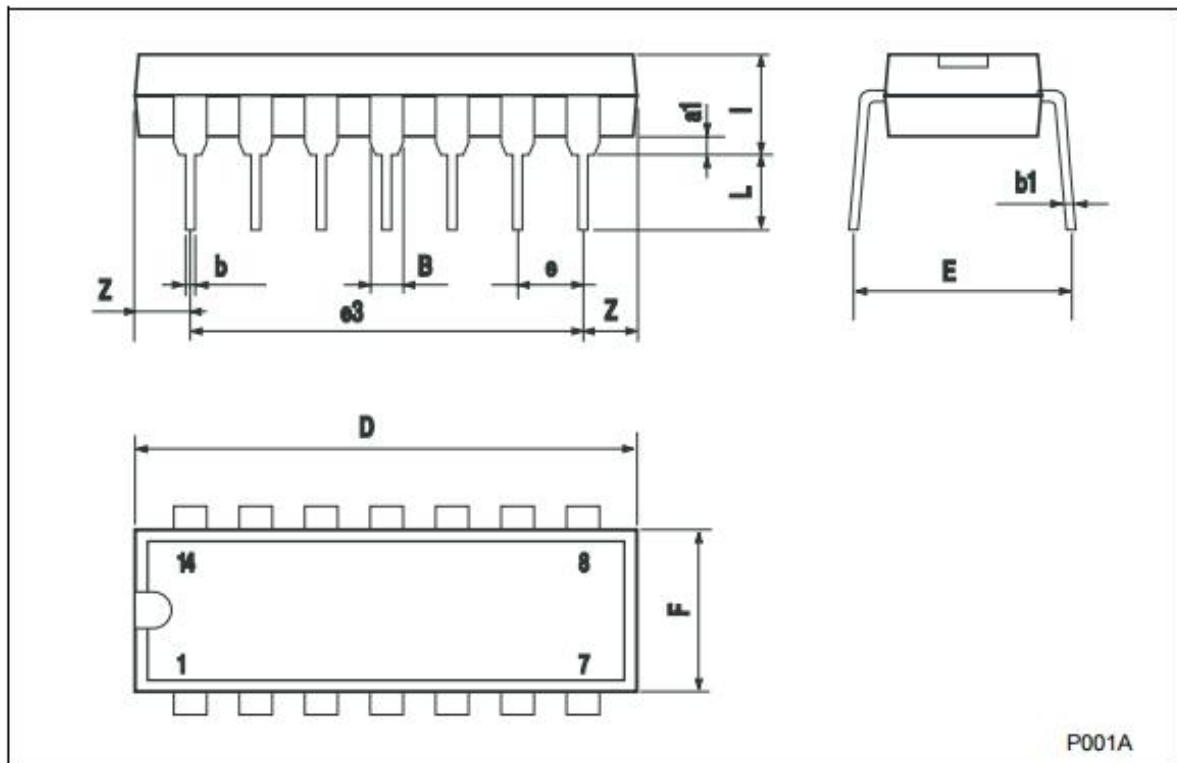

6.2 SOP14

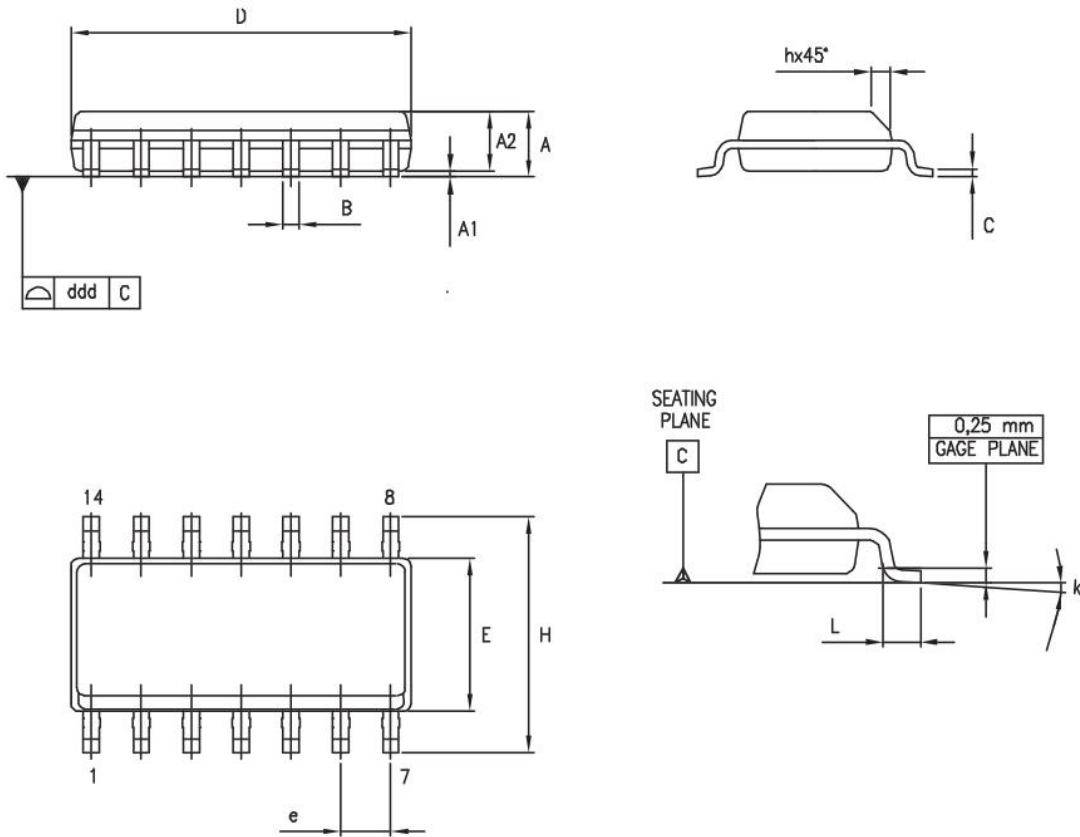

Dimensions						
Ref.	Millimeters			Inches		
	Min.	Typ.	Max.	Min.	Typ.	Max.
A	1.35		1.75	0.05		0.068
A1	0.10		0.25	0.004		0.009
A2	1.10		1.65	0.04		0.06
B	0.33		0.51	0.01		0.02
C	0.19		0.25	0.007		0.009
D	8.55		8.75	0.33		0.34
E	3.80		4.0	0.15		0.15
e		1.27			0.05	
H	5.80		6.20	0.22		0.24
h	0.25		0.50	0.009		0.02
L	0.40		1.27	0.015		0.05
k	8° (max.)					
ddd			0.10			0.004

6.3 TSSOP14

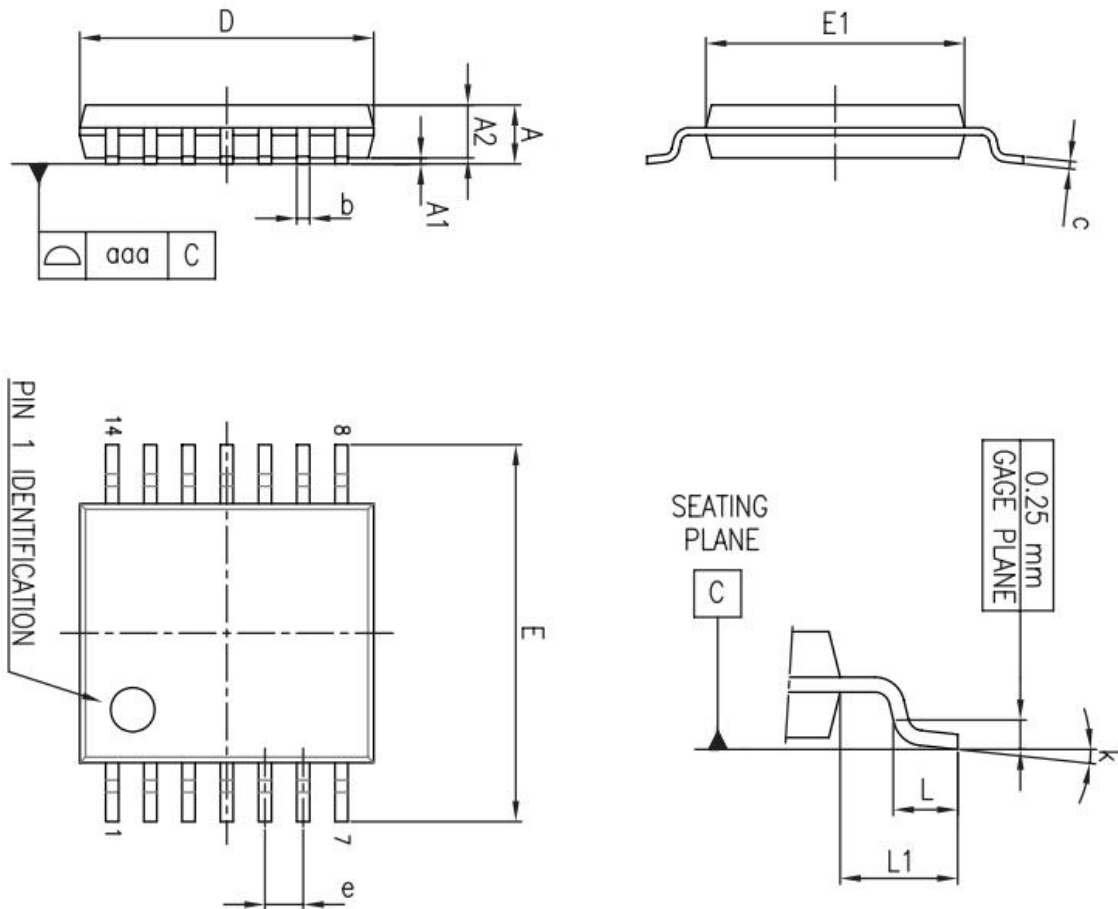

Ref.	Dimensions					
	Millimeters			Inches		
	Min.	Typ.	Max.	Min.	Typ.	Max.
A			1.20			0.047
A1	0.05		0.15	0.002	0.004	0.006
A2	0.80	1.00	1.05	0.031	0.039	0.041
b	0.19		0.30	0.007		0.012
c	0.09		0.20	0.004		0.0089
D	4.90	5.00	5.10	0.193	0.197	0.201
E	6.20	6.40	6.60	0.244	0.252	0.260
E1	4.30	4.40	4.50	0.169	0.173	0.176
e		0.65			0.0256	
L	0.45	0.60	0.75	0.018	0.024	0.030
L1		1.00			0.039	
k	0°		8°	0°		8°
aaa			0.10			0.004