

修订 REV	标记 MARK	修改摘要 REVISION DESCRIPTION	签名 SIGNATURE	日期 DATE
AO		NEW RELEASE	WANG	2015-06-20

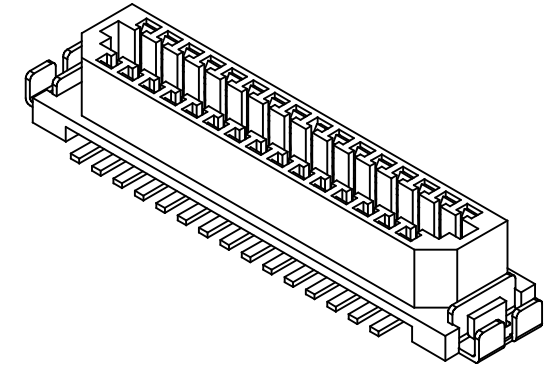

Ordering Information & Dimensions

Circuits	Dimensions(mm)				
	A	B	C	D	E
9P	4.00	8.30	6.55	7.10	10.10
11P	5.00	9.30	7.55	8.10	11.10
13P	6.00	10.30	8.55	9.10	12.10
15P	7.00	11.30	9.55	10.10	13.10
17P	8.00	12.30	10.55	11.10	14.10
19P	9.00	13.30	11.55	12.10	15.10
21P	10.00	14.30	12.55	13.10	16.10
23P	11.00	15.30	13.55	14.10	17.10
25P	12.00	16.30	14.55	15.10	18.10
31P	15.00	19.30	17.55	18.10	21.10
41P	20.00	24.30	22.55	23.10	26.10
51P	25.00	29.30	27.55	28.10	31.10

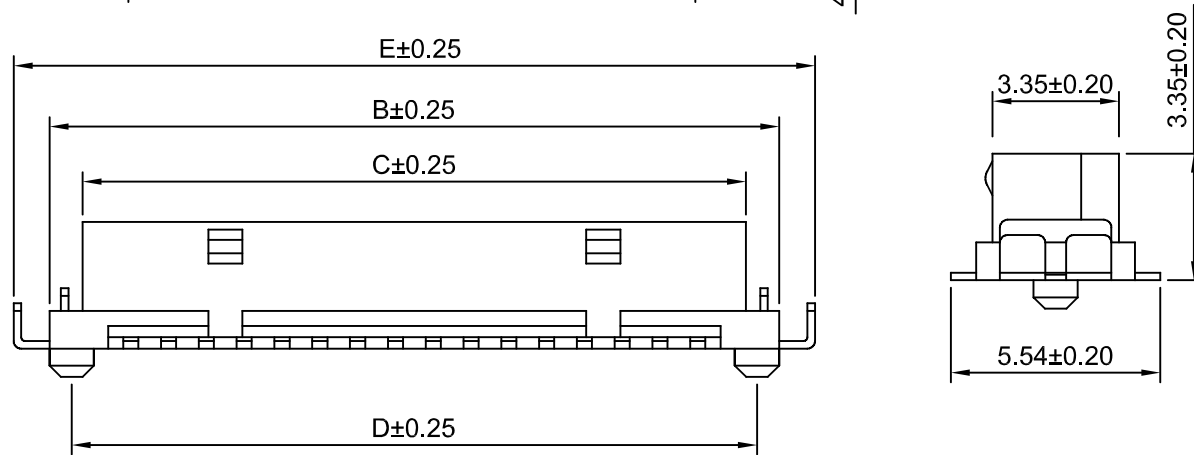
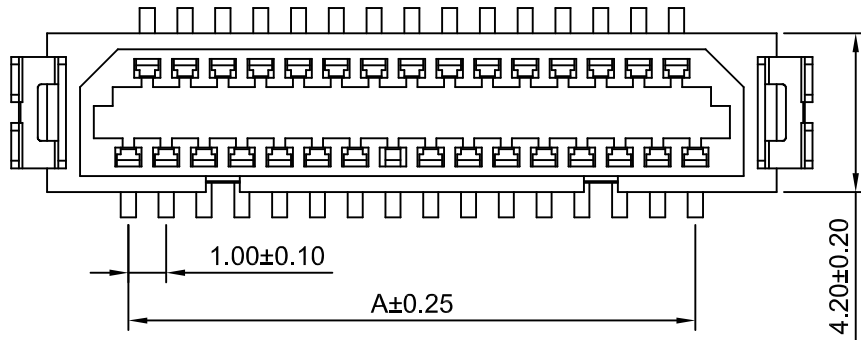
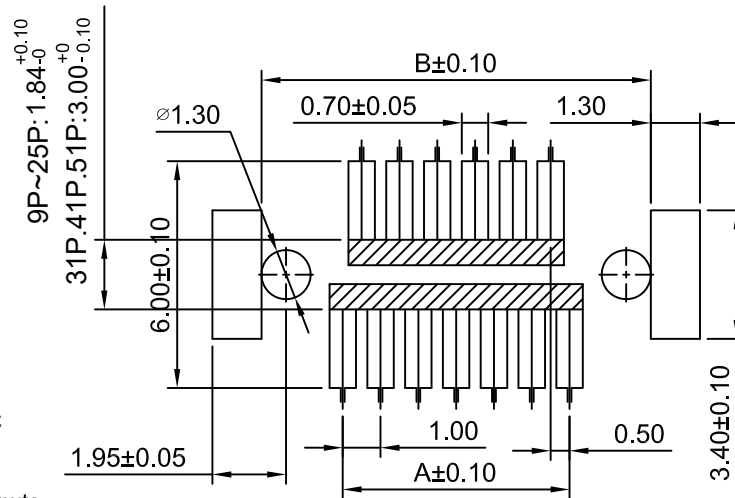

SPECIFICATIONS:

Current Rating: 0.5A AC,DC
Voltage Rating: 150V AC,DC
Temperature Range: -25°C~+85°C
Contact Resistance: 50mΩ Max
Insulation Resistance: 500MΩ Min
Withstanding Voltage: 250V AC/minute
Pin Material: Phosphor Bronze/Tin over Nickel
Material: Nylon6T, UL94V-0(Beige)

P.C.B YAYOUT



深圳市华德共创科技有限公司

Shenzhen Huade co-create Technology Co.,LTD

TEL : 0755-27111216 FAX : 0755-29940187

-TOLERANCES- UNLESS OTHERWISE SPECIFIED 公差参数表				TITLE: 1.00mm pitch board to 产品名称: board connector	
X.X	±0.30	X.X°	±3°	APPD: 核准:	XIE
X.XX	±0.30	X.XX°	±2°	CHECK: 校对:	WANG
X.XXX	±0.10	X.XXX°	±1°	DRAW: 绘图:	WANG
PART NO: 产品编号:		HDGC1000H-S-F-XP			
DATE	SCALE	UNIT	CODE NUMBER		
2015-06-20	5:1	mm	A008		