

## 11MHz CMOS Rail-to-Rail IO Opamps

### Features

- Single-Supply Operation from +2.1V ~ +5.5V
- Rail-to-Rail Input / Output
- Gain-Bandwidth Product: 11MHz (Typ.)
- Low Input Bias Current: 1pA (Typ.)
- Low Offset Voltage: 3.5mV (Max.)
- High Slew Rate: 9V/μs
- Settling Time to 0.1% with 2V Step: 0.3μs
- Low Noise : 8nV/ Hz @10kHz
- Quiescent Current: 1.1mA per Amplifier (Typ.)
- Operating Temperature: -40°C ~ +125°C
- Small Package:

LMV721 Available in SOT23-5 SC70-5 SOP-8 and MSOP-8 Packages

LMV722 Available in SOP-8 and MSOP-8 Packages

LMV724 Available in SOP-14 and TSSOP-14 Packages

LMV721N Available in SOT23-6 Packages



### Ordering Information

DEVICE	Package Type	MARKING	Packing	Packing Qty
LMV721M5/TR	SOT-23-5	V721,LMV721,A30A	REEL	3000pcs/reel
LMV721M7/TR	SC70-5(SOT-353)	V721	REEL	3000pcs/reel
LMV721M/TR	SOP-8	LMV721	REEL	2500pcs/reel
LMV721MM/TR	MSOP-8	V721	REEL	3000pcs/reel
LMV721NM6/TR	SOT-23-6	V721N	REEL	3000pcs/reel
LMV721NM7/TR	SC70-6	V721N	REEL	3000pcs/reel
LMV722M/TR	SOP-8	LMV722	REEL	2500pcs/reel
LMV722MM/TR	MSOP-8	LMV722,V722	REEL	3000pcs/reel
LMV724M/TR	SOP-14	LMV724	REEL	2500pcs/reel
LMV724MT/TR	TSSOP-14	LMV724	REEL	2500pcs/reel

## General Description

The LMV72X have a high gain-bandwidth product of 11 MHz, a slew rate of 9V/ $\mu$ s, and a quiescent current of 1.1mA per amplifier at 5V. The LMV721N has a power-down disable feature that reduces the supply current to 90nA. The LMV72X are designed to provide optimal performance in low voltage and low noise systems. They provide rail-to-rail output swing into heavy loads. The input common mode voltage range includes ground, and the maximum input offset voltage is 3.5mV for LMV72X. They are specified over the extended industrial temperature range (-40°C to +125°C). The operating range is from 2.1V to 5.5V. The LMV721 single is available in Green SC70-5, SOT23-5, SOP-8 and MSOP-8 packages. The LMV722 dual is available in Green SOP-8 and MSOP-8 packages. The LMV724 Quad is available in Green SOP-14 and TSSOP-14 packages. The LMV721N single with shutdown is available in Green SOT23-6 and SC70-6 packages.

## Applications

- Sensors
- Active Filters
- Cellular and Cordless Phones
- Laptops and PDAs
- Audio
- Handheld Test Equipment
- Battery-Powered Instrumentation
- A/D Converters

## Pin Configuration

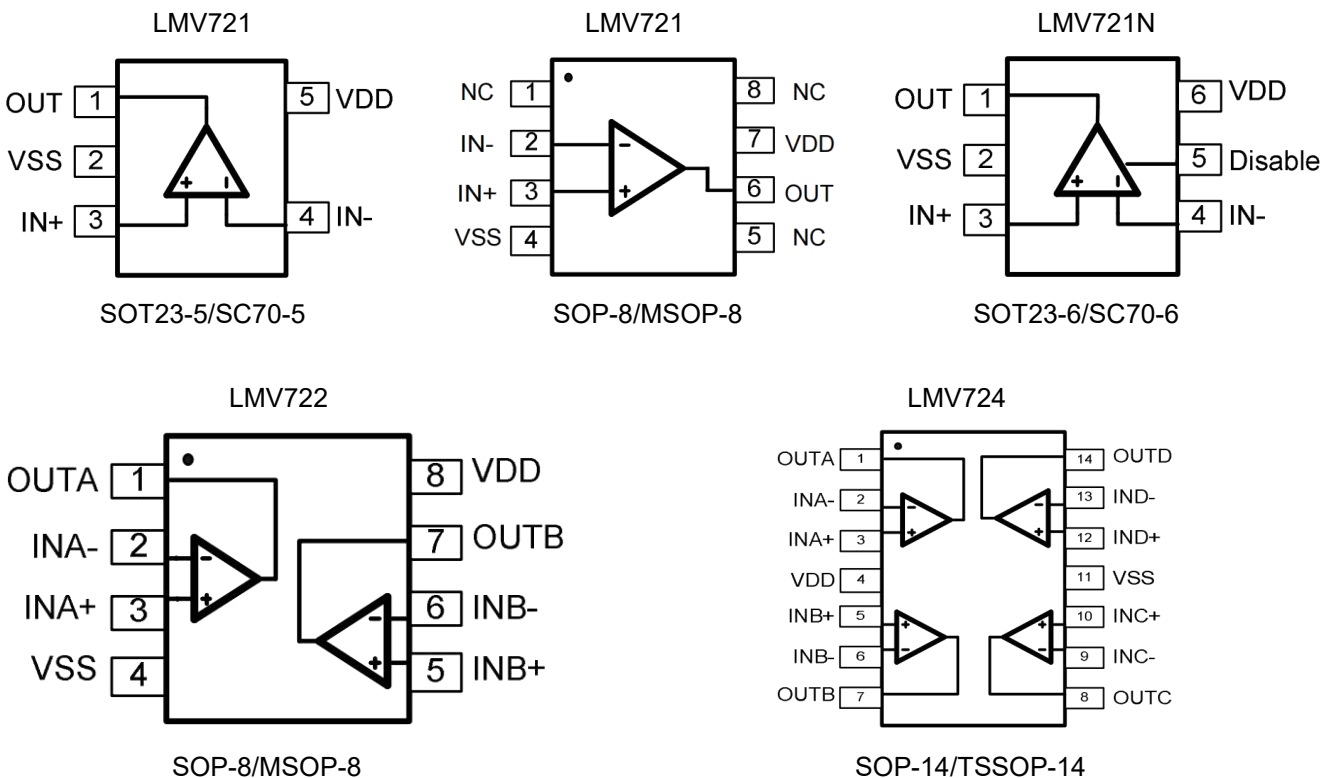

Figure 1. Pin Assignment Diagram

## Absolute Maximum Ratings

Condition	Min	Max
Power Supply Voltage (VDD to Vss)	-0.5V	+7.5V
Analog Input Voltage (IN+ or IN-)	Vss-0.5V	VDD+0.5V
PDB Input Voltage	Vss-0.5V	+7V
Operating Temperature Range <sup>(1)</sup>	-40°C	+125°C
Junction Temperature	-	+160°C
Storage Temperature Range	-55°C	+150°C
Lead Temperature (soldering, 10sec)	-	+260°C
<b>Package Thermal Resistance (TA=+25°C)</b>		
SOP-8, $\theta_{JA}$	-	125°C/W
MSOP-8, $\theta_{JA}$	-	216°C/W
SOT23-5, $\theta_{JA}$	-	190°C/W
SOT23-6, $\theta_{JA}$	-	190°C/W
SC70-5, $\theta_{JA}$	-	333°C/W
<b>ESD Susceptibility</b>		
HBM	-	8KV
MM	-	400V

**Note:** Stress greater than those listed under Absolute Maximum Ratings may cause permanent damage to the device. This is a stress rating only and functional operation of the device at these or any other conditions outside those indicated in the operational sections of this specification are not implied. Exposure to absolute maximum rating conditions for extended periods may affect reliability.

**Note(1)** :Operating temperature range: -40°C to +125°C. This product is designed for industrial grade applications. For automotive grade versions compliant with AEC-Q100, please conduct internal screening per the standard or contact our sales team for availability.

**Electrical Characteristics**

 (At  $V_S=5V$ ,  $T_A = +25^\circ C$ ,  $V_{CM} = V_S/2$ ,  $R_L = 600\Omega$ , unless otherwise noted.)

PARAMETER	CONDITIONS	LMV721/2/4/1N							
		TYP	MIN/MAX OVER TEMPERATURE					UNITS	MIN / MAX
		+25°C	+25°C	0°C to 70°C	-40°C to 85°C	-40°C to 125°C			
<b>INPUT CHARACTERISTICS</b>									
Input Offset Voltage (VOS)	$V_S = 5.5V$	0.8	3.5	3.9	4.3	4.6	mV	MAX	
Input Bias Current (IB)		1					pA	TYP	
Input Offset Current (IOS)		1					pA	TYP	
Input Common Mode Voltage Range (VCM)		-0.1 to +5.6					V	TYP	
Common Mode Rejection Ratio (CMRR)	$V_S = 5.5V, V_{CM} = -0.1V$ to 4V	82	65	64	64	63	dB	MIN	
Open-Loop Voltage Gain (AOL)	$V_S = 5.5V, V_{CM} = -0.1V$ to 5.6V	75					dB	MIN	
	$R_L = 600\Omega, V_O = 0.15V$ to 4.85V	90	80	76	75	68	dB	MIN	
Input Offset Voltage Drift ( $\Delta V_{OS}/\Delta T$ )	$R_L = 10k\Omega, V_O = 0.05V$ to 4.95V	108					dB	MIN	
		2.4					$\mu V/^\circ C$	TYP	
<b>OUTPUT CHARACTERISTICS</b>									
Output Voltage Swing from Rail	$R_L = 600\Omega$ $R_L = 10k\Omega$	0.1 0.015					V V	TYP TYP	
Output Current (IOUT)		70	55	45	42	38	mA	MIN	
Closed-Loop Output Impedance	$f = 100kHz, G = 1$	7.5					$\Omega$	TYP	
<b>POWER-DOWN DISABLE</b>									
Turn-On Time		1.1					$\mu s$	TYP	
Turn-Off Time		0.3					$\mu s$	TYP	
DISABLE Voltage-Off			0.8				V	MAX	
DISABLE Voltage-On			2				V	MIN	
<b>POWER SUPPLY</b>									
Operating Voltage Range			2.1 5.5	2.1 5.5	2.1 5.5	2.1 5.5	V V	MIN MAX	
Power Supply Rejection Ratio (PSRR)	$V_S = +2.5V$ to +5.5V	91	74	72	72	68	Db	MIN	
Quiescent Current/Amplifier (IQ)	$V_{CM} = (-V_S) + 0.5V$	1.1	1.5	1.65	1.7	1.85	mA	MAX	
Supply Current when Disabled (LMV721N Only)	$I_{OUT} = 0$	90					nA	MAX	

## Electrical Characteristics

(At  $V_s=5V$ ,  $T_A = +25^\circ C$ ,  $V_{CM} = V_S/2$ ,  $R_L = 600\Omega$ , unless otherwise noted.)

PARAMETER	CONDITIONS	LMV721/2/4/1N							
		TYP	MIN/MAX OVER TEMPERATURE					UNITS	MIN / MAX
		+25°C	+25°C	0°C to 70°C	-40°C to 85°C	-40°C to 125°C			
<b>DYNAMIC PERFORMANCE</b>									
Gain-Bandwidth Product (GBP)	$R_L = 10k\Omega$ , $C_L = 100pF$	11					MHz	TYP	
Phase Margin ( $\phi_O$ )	$R_L = 10k\Omega$ , $C_L = 100pF$	51					Degrees	TYP	
Full Power Bandwidth (BWP)	<1% distortion, $R_L = 600\Omega$	400					kHz	TYP	
Slew Rate (SR)	$G = +1$ , 2V Step, $R_L = 10k\Omega$	9					V/ $\mu s$	TYP	
Settling Time to 0.1% ( $t_S$ )	$G = +1$ , 2V Step, $R_L = 600\Omega$	0.3					$\mu s$	TYP	
Overload Recovery Time	$V_{IN} \cdot Gain = V_S$ , $R_L = 600\Omega$	1.5					$\mu s$	TYP	
<b>NOISE PERFORMANCE</b>									
Voltage Noise Density ( $e_n$ )	$f = 1kHz$	11.5					nV /Hz	TYP	
	$f = 10kHz$	8					nV /Hz	TYP	

## Typical Performance characteristics

(At  $V_s=5V$ ,  $T_A=+25^\circ C$ ,  $V_{CM}=V_s/2$ ,  $R_L=600\Omega$ , unless otherwise noted.)

Large-Signal Step Response

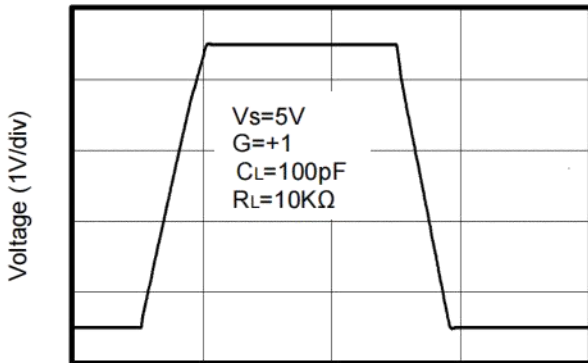

Time (1µs/div)

Large-Signal Step Response

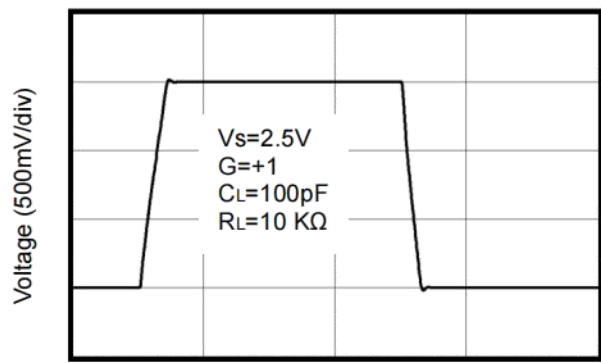

Time (1µs/div)

Small-Signal Step Response

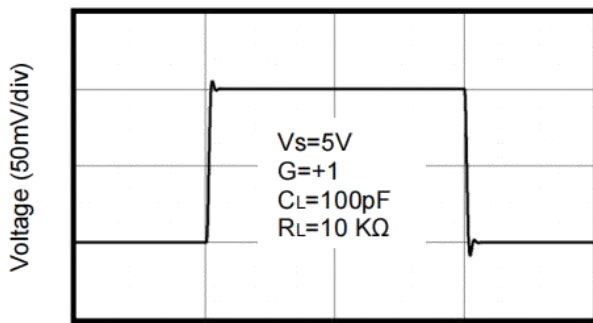

Time (1µs/div)

Small-Signal Step Response

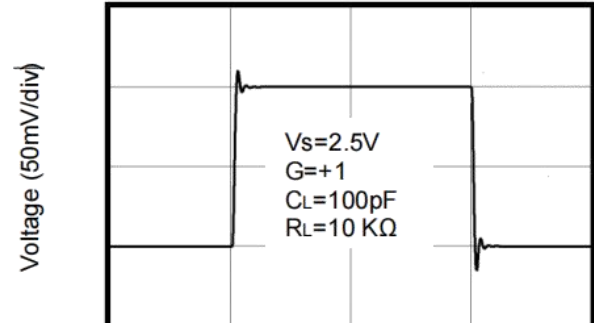

Time (1µs/div)

Positive Overload Recovery

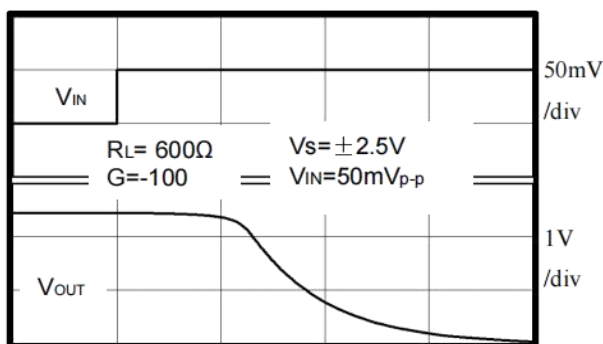

Time (2µs/div)

Negative Overload Recovery

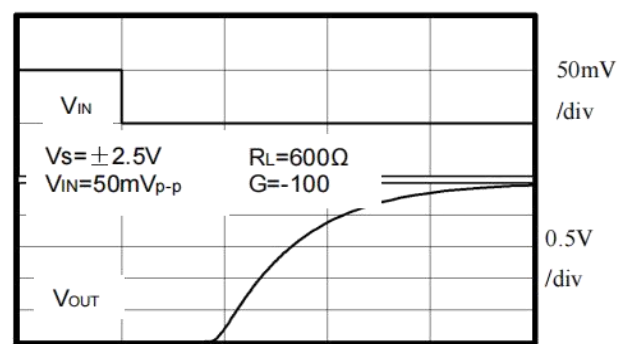

Time (2µs/div)

**Typical Performance characteristics**

(At  $V_s=5V$ ,  $T_A = +25^\circ C$ ,  $V_{CM} = V_S/2$ ,  $R_L = 600\Omega$ , unless otherwise noted.)

Output Voltage Swing vs. Output Current

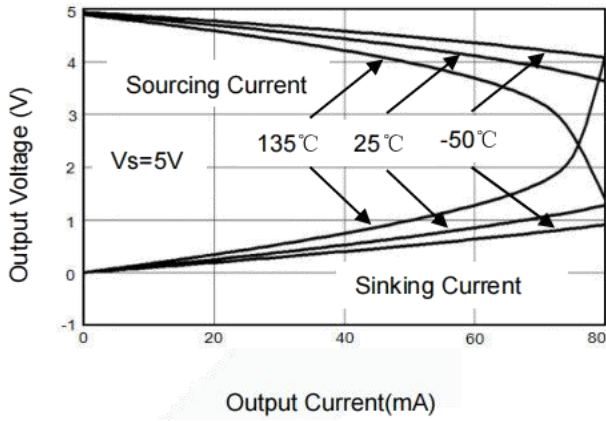

Supply Current vs. Temperature

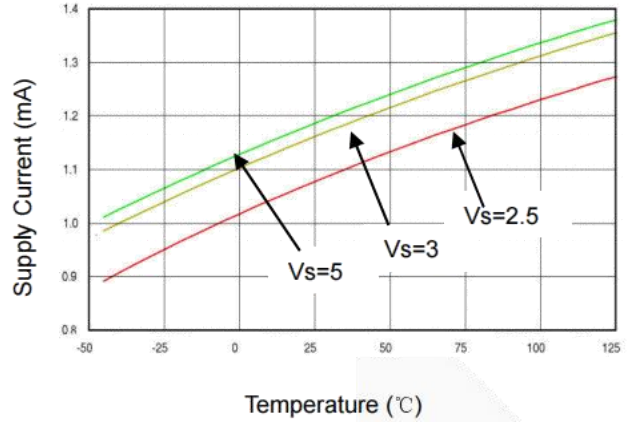

Input Voltage Noise Spectral Density vs. Frequency

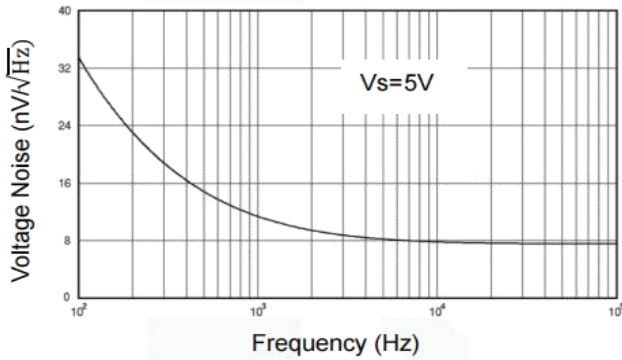

Open Loop Gain, Phase Shift vs. Frequency

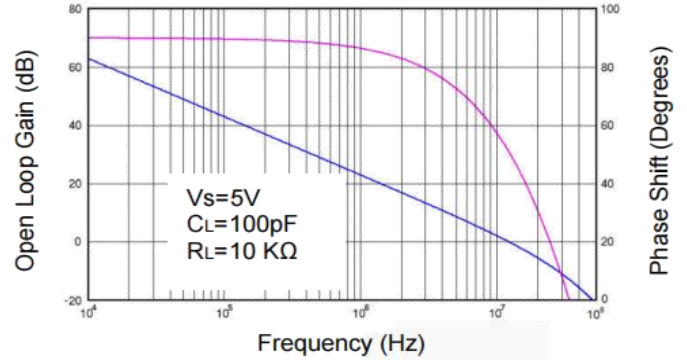

CMRR vs. Frequency

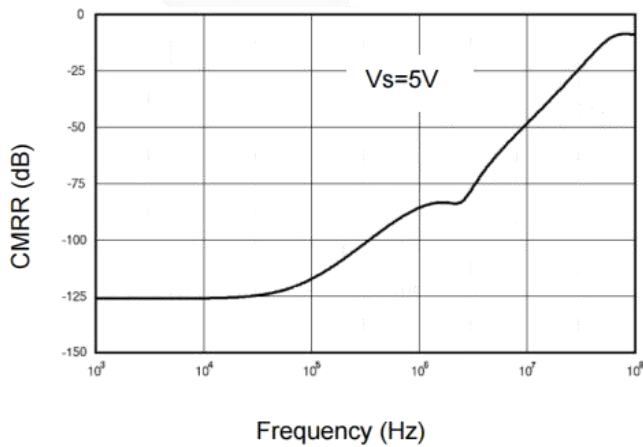

PSRR vs. Frequency

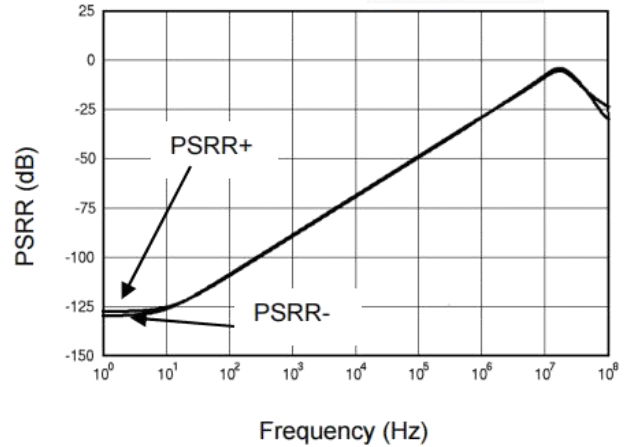

## Application Note

### Size

LMV72X series op amps are unity-gain stable and suitable for a wide range of general-purpose applications. The small footprints of the LMV72X series packages save space on printed circuit boards and enable the design of smaller electronic products.

### Power Supply Bypassing and Board Layout

LMV72X series operates from a single 2.1V to 5.5V supply or dual  $\pm 1.05V$  to  $\pm 2.75V$  supplies. For best performance, a 0.1 $\mu F$  ceramic capacitor should be placed close to the VDD pin in single supply operation. For dual supply operation, both VDD and VSS supplies should be bypassed to ground with separate 0.1 $\mu F$  ceramic capacitors.

### Low Supply Current

The low supply current (typical 1.1mA per channel) of LMV72X series will help to maximize battery life . They are ideal for battery powered systems

### Operating Voltage

LMV72X series operate under wide input supply voltage (2.1V to 5.5V). In addition, all temperature specifications apply from  $-40^{\circ}C$  to  $+125^{\circ}C$ . Most behavior remains unchanged throughout the full operating voltage range. These guarantees ensure operation throughout the single Li-Ion battery lifetime

### Rail-to-Rail Input

The input common-mode range of LMV72X series extends 100mV beyond the supply rails ( $V_{SS}-0.1V$  to  $V_{DD}+0.1V$ ). This is achieved by using complementary input stage. For normal operation, inputs should be limited to this range.

### Rail-to-Rail Output

Rail-to-Rail output swing provides maximum possible dynamic range at the output. This is particularly important when operating in low supply voltages. The output voltage of LMV72X series can typically swing to less than 2mV from supply rail in light resistive loads ( $>100k\Omega$ ), and 15mV of supply rail in moderate resistive loads (10k $\Omega$ ).

### Capacitive Load Tolerance

The LMV72X family is optimized for bandwidth and speed, not for driving capacitive loads. Output capacitance will create a pole in the amplifier's feedback path, leading to excessive peaking and potential oscillation. If dealing with load capacitance is a requirement of the application, the two strategies to consider are (1) using a small resistor in series with the amplifier's output and the load capacitance and (2) reducing the bandwidth of the amplifier's feedback loop by increasing the overall noise gain.

Figure 2. shows a unity gain follower using the series resistor strategy. The resistor isolates the output from the capacitance and, more importantly, creates a zero in the feedback path that compensates for the pole created by the output capacitance.

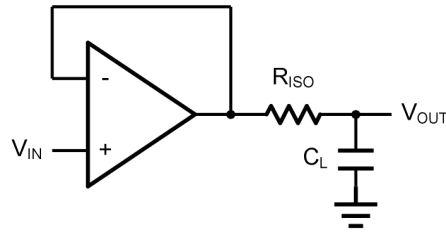

Figure 2. Indirectly Driving a Capacitive Load Using Isolation Resistor

The bigger the  $R_{ISO}$  resistor value, the more stable  $V_{OUT}$  will be. However, if there is a resistive load  $R_L$  in parallel with the capacitive load, a voltage divider (proportional to  $R_{ISO}/R_L$ ) is formed, this will result in a gain error.

The circuit in Figure 3 is an improvement to the one in Figure 2.  $R_F$  provides the DC accuracy by feed-forward the  $V_{IN}$  to  $R_L$ .  $C_F$  and  $R_{ISO}$  serve to counteract the loss of phase margin by feeding the high frequency component of the output signal back to the amplifier's inverting input, thereby preserving the phase margin in the overall feedback loop. Capacitive drive can be increased by increasing the value of  $C_F$ . This in turn will slow down the pulse response.

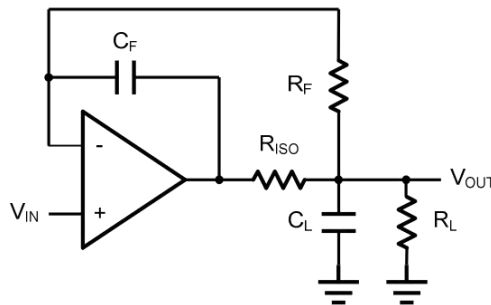

Figure 3. Indirectly Driving a Capacitive Load with DC Accuracy

## Typical Application Circuits

### Differential amplifier

The differential amplifier allows the subtraction of two input voltages or cancellation of a signal common to the two inputs. It is useful as a computational amplifier in making a differential to single-end conversion or in rejecting a common mode signal.

Figure 4. shows the differential amplifier using LMV72X.

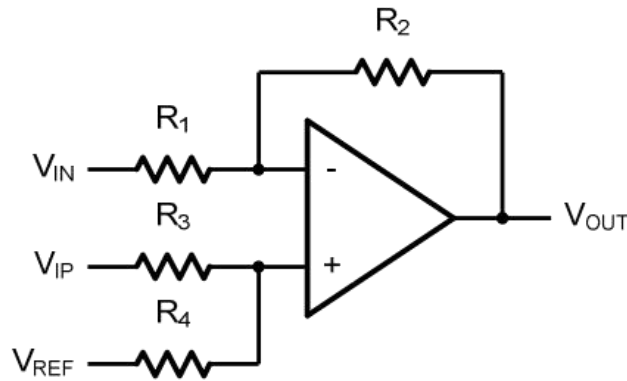

Figure 4. Differential Amplifier

$$V_{OUT} = \left(\frac{R_1 + R_2}{R_3 + R_4}\right) \frac{R_4}{R_1} V_{IN} - \frac{R_2}{R_1} V_{IP} + \left(\frac{R_1 + R_2}{R_3 + R_4}\right) \frac{R_3}{R_1} V_{REF}$$

If the resistor ratios are equal (i.e.  $R_1=R_3$  and  $R_2=R_4$ ), then

$$V_{OUT} = \frac{R_2}{R_1} (V_{IP} - V_{IN}) + V_{REF}$$

### Low Pass Active Filter

The low pass active filter is shown in Figure 5. The DC gain is defined by  $-R_2/R_1$ . The filter has a -20dB/decade roll-off after its corner frequency  $f_C=1/(2\pi R_3 C_1)$ .

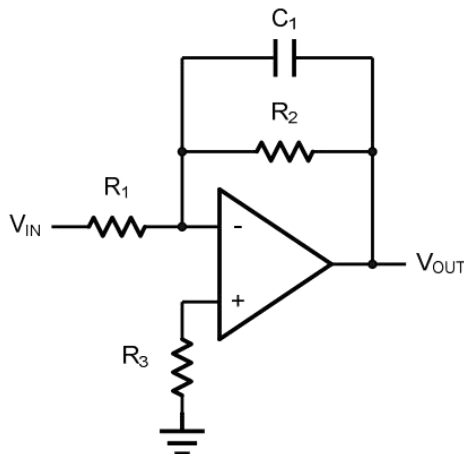

Figure 5. Low Pass Active Filter

## Instrumentation Amplifier

The triple LMV72X can be used to build a three-op-amp instrumentation amplifier as shown in Figure 6. The amplifier in Figure 6 is a high input impedance differential amplifier with gain of  $R_2/R_1$ . The two differential voltage followers assure the high input impedance of the amplifier.

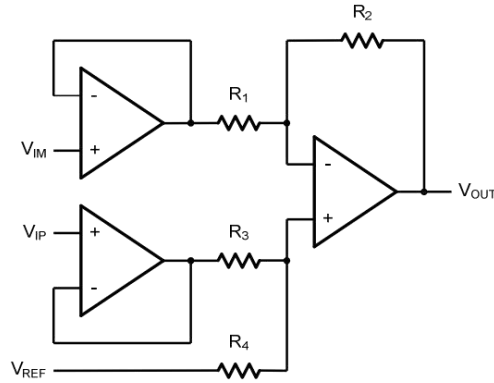
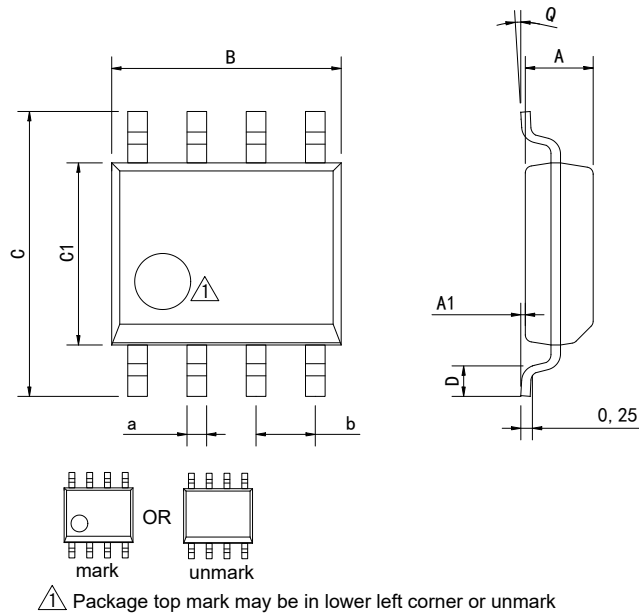

Figure 6. Instrument Amplifier

## Physical Dimensions

### SOP-8



Dimensions In Millimeters(SOP-8)									
Symbol:	A	A1	B	C	C1	D	Q	a	b
Min:	1.35	0.05	4.90	5.80	3.80	0.40	0°	0.35	1.27 BSC
Max:	1.55	0.20	5.10	6.20	4.00	0.80	8°	0.45	

### MSOP-8

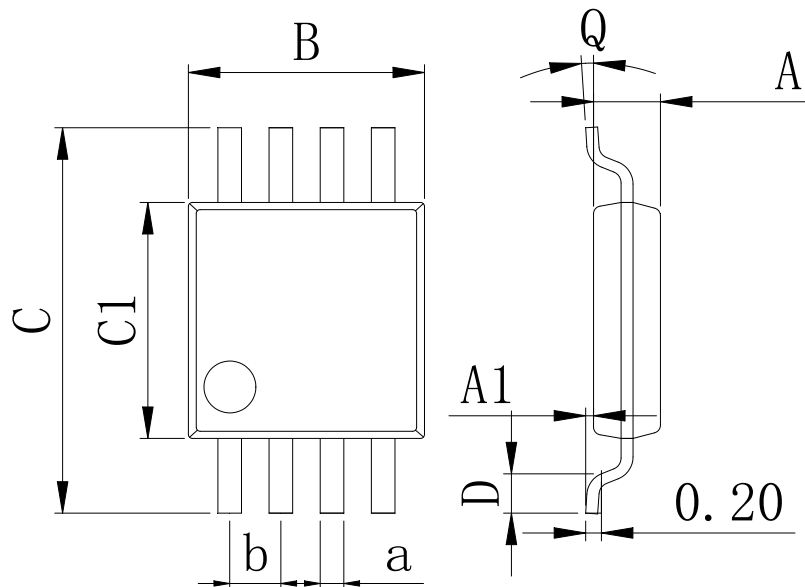

Dimensions In Millimeters(MSOP-8)									
Symbol:	A	A1	B	C	C1	D	Q	a	b
Min:	0.80	0.05	2.90	4.75	2.90	0.35	0°	0.25	0.65 BSC
Max:	0.90	0.20	3.10	5.05	3.10	0.75	8°	0.35	

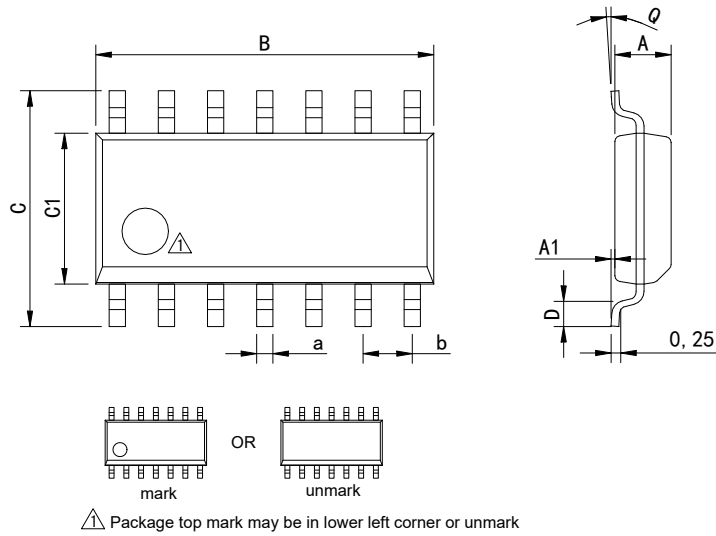
**Physical Dimensions**
**SOP-14**

Dimensions In Millimeters(SOP-14)									
Symbol:	A	A1	B	C	C1	D	Q	a	b
Min:	1.35	0.05	8.55	5.80	3.80	0.40	0°	0.35	1.27 BSC
Max:	1.55	0.20	8.75	6.20	4.00	0.80	8°	0.45	

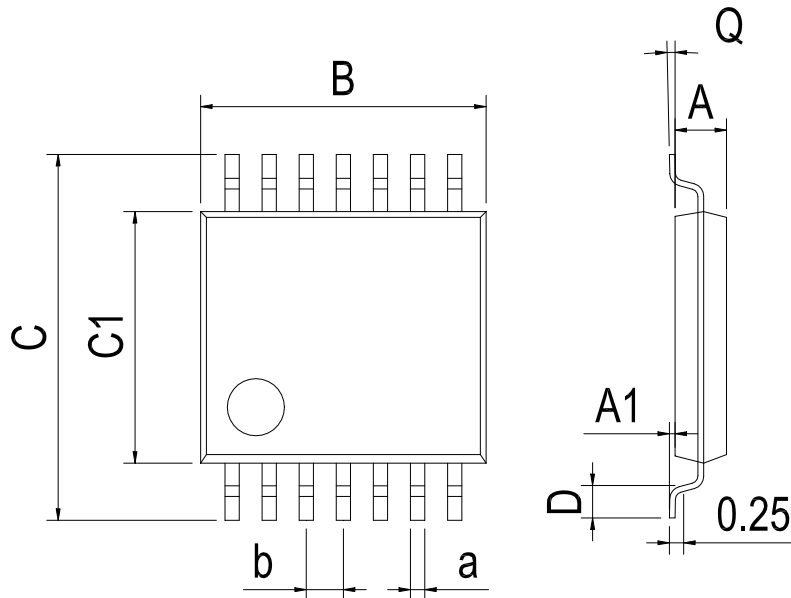
**TSSOP-14**

Dimensions In Millimeters(TSSOP-14)									
Symbol:	A	A1	B	C	C1	D	Q	a	b
Min:	0.85	0.05	4.90	6.20	4.30	0.40	0°	0.20	0.65 BSC
Max:	0.95	0.20	5.10	6.60	4.50	0.80	8°	0.25	

**Physical Dimensions**

SOT-23-5

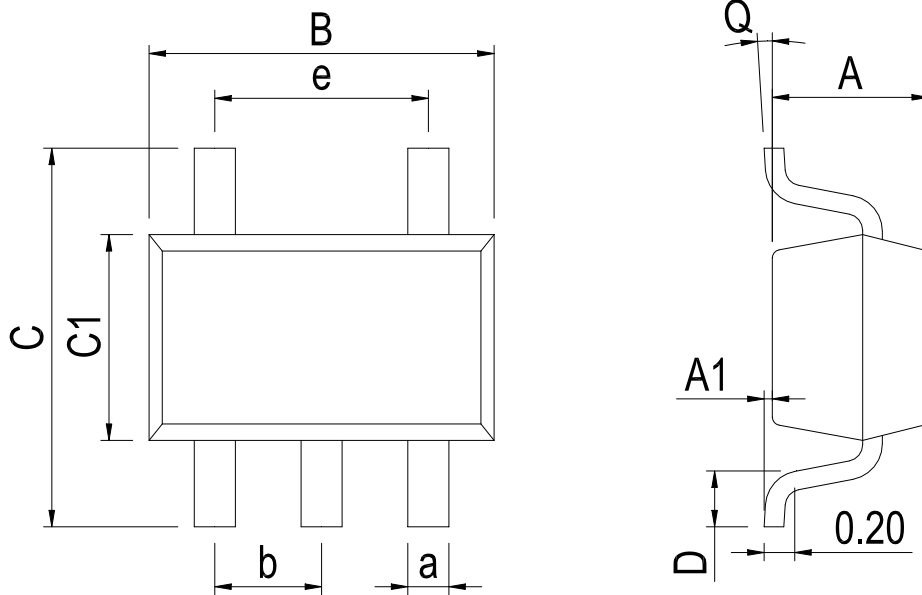

**Dimensions In Millimeters(SOT-23-5)**

Symbol:	A	A1	B	C	C1	D	Q	a	b	e
Min:	1.00	0.00	2.82	2.65	1.50	0.30	0°	0.30	0.95 BSC	1.90 BSC
Max:	1.15	0.15	3.02	2.95	1.70	0.60	8°	0.50		

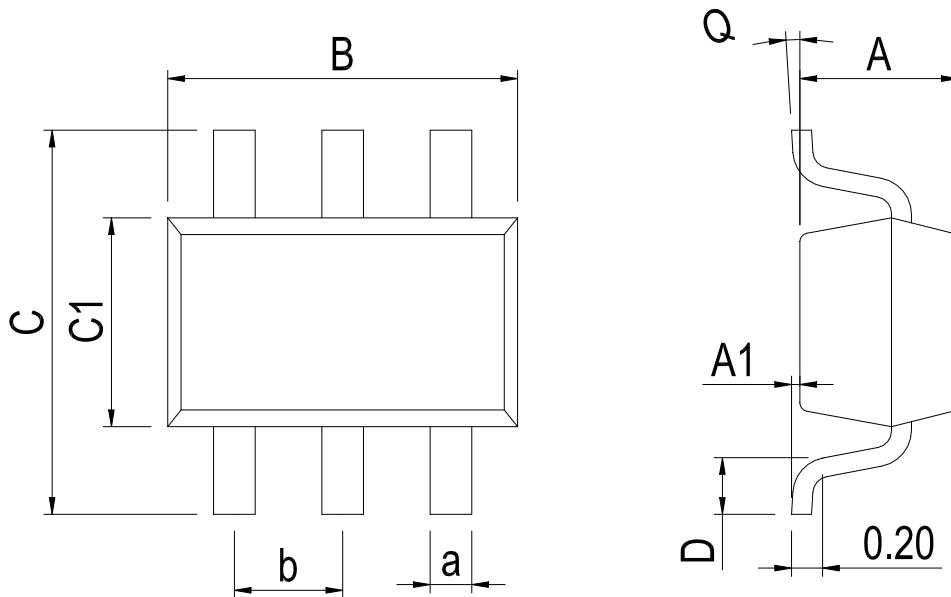
SOT-23-6

**Dimensions In Millimeters(SOT-23-6)**

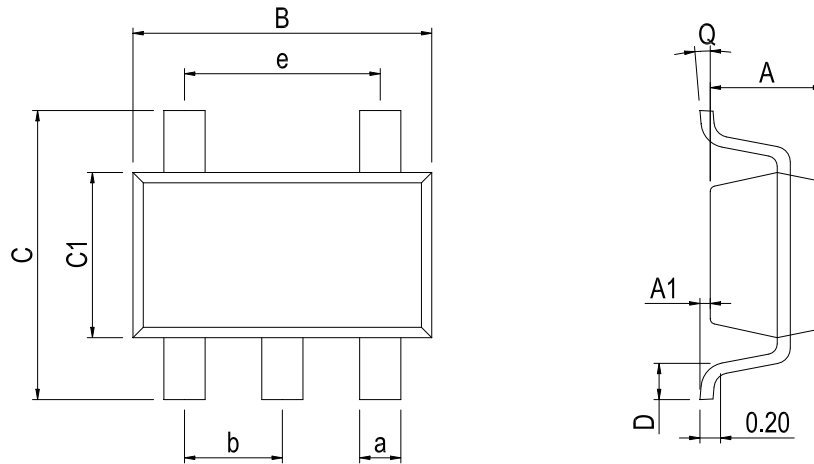
Symbol:	A	A1	B	C	C1	D	Q	a	b
Min:	1.00	0.00	2.82	2.65	1.50	0.30	0°	0.30	0.95 BSC
Max:	1.15	0.15	3.02	2.95	1.70	0.60	8°	0.50	

**Physical Dimensions**
**SC70-5**

Dimensions In Millimeters(SC70-5)										
Symbol:	A	A1	B	C	C1	D	Q	a	b	e
Min:	0.90	0.00	2.00	2.15	1.15	0.26	0°	0.15	0.65	1.30 BSC
Max:	1.00	0.15	2.20	2.45	1.35	0.46	8°	0.35	BSC	

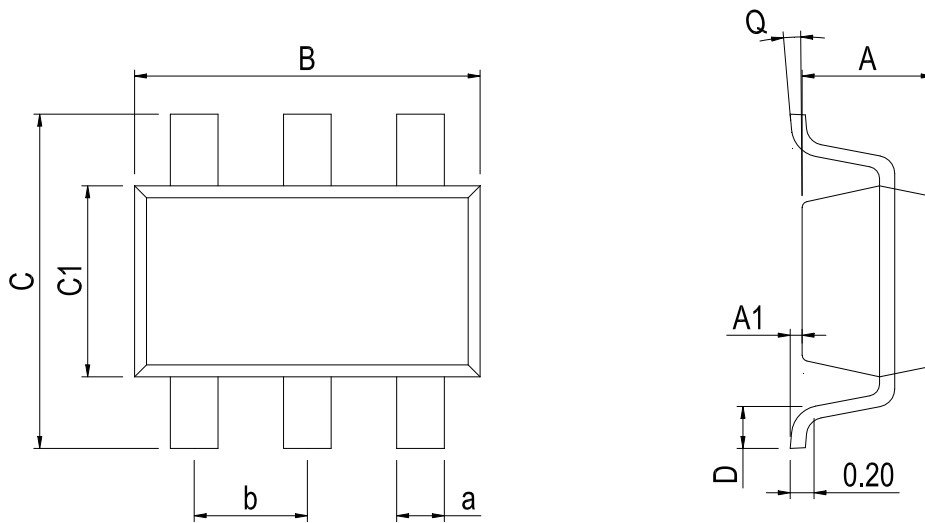
**SC70-6**

Dimensions In Millimeters(SC70-6)									
Symbol:	A	A1	B	C	C1	D	Q	a	b
Min:	0.90	0.00	2.00	2.15	1.15	0.26	0°	0.15	0.65 BSC
Max:	1.00	0.15	2.20	2.45	1.35	0.46	8°	0.35	

## Revision History

REVISION NUMBER	DATE	REVISION	PAGE
V1.0	2016-7	New	1-17
V1.1	2018-7	Update encapsulation type、 update sc70-5 and sc70-6 Physical Dimensions	1、 15
V1.2	2024-10	Update SOT-23-5 and SOT-23-6 Physical dimension	14
V1.3	2025-12	Update important statements、 Update SOP-8 and SOP-14 Dimension drawing	12、 13、 17

**IMPORTANT STATEMENT:**

Huaguan Semiconductor reserves the right to change products and services offered without prior notice. Customers should obtain the latest relevant information before placing orders and verify that such information is current and complete. Huaguan Semiconductor assumes no responsibility or liability for altered documents.

Customers are responsible for complying with safety standards and implementing safety measures when using Huaguan Semiconductor products in system design and end-product manufacturing. You assume full responsibility for: selecting the appropriate Huaguan Semiconductor products for your application; designing, validating, and testing your application; and ensuring that your application complies with applicable standards and all other safety, security, or other requirements. This is to prevent potential risks that may lead to personal injury or property damage.

Huaguan Semiconductor products are not approved for use in life support, military, aerospace, or other high-risk applications. Huaguan products are neither intended nor warranted for use in such systems or equipment. Any failure or malfunction may lead to personal injury or severe property damage. Such applications are deemed "Unsafe Use." Unsafe Use includes, but is not limited to: surgical and medical equipment, nuclear energy control equipment, aircraft or spacecraft instruments, control or operation of vehicle power, braking, or safety systems, traffic signal instruments, all types of safety devices, and any other applications intended to support or sustain life. Huaguan Semiconductor shall not be liable for consequences resulting from Unsafe Use in these fields. Users must independently evaluate and assume all risks. Any issues, liabilities, or losses arising from the use of products beyond their approved applications shall be solely borne by the user. Users may not claim any compensation from Huaguan Semiconductor based on these terms. If any third party claims against Huaguan Semiconductor due to such Unsafe Use, the user shall compensate Huaguan Semiconductor for all resulting damages and liabilities.

Huaguan Semiconductor provides technical and reliability data (including datasheets), design resources (including reference designs), application or other design advice, web tools, safety information, and other resources for its semiconductor products. However, no guarantee is made that these resources are free from defects, and no express or implied warranties are provided. The use of testing and other quality control techniques is limited to Huaguan Semiconductor's quality assurance scope. Not all parameters of each device are tested.

Huaguan Semiconductor's documentation authorizes you to use these resources only for developing applications related to the products described herein. You are not granted rights to any other intellectual property of Huaguan Semiconductor or any third party. Any other reproduction or display of these resources is strictly prohibited. You shall fully indemnify Huaguan Semiconductor and its agents against any claims, damages, costs, losses, and liabilities arising from your use of these resources. Huaguan Semiconductor shall not be held responsible.