

修订	标记	修改摘要	签名	日期
REV	MARK	REVISION DESCRIPTION	SIGNATURE	DATE
AO		NEW DWG		2016-03-12

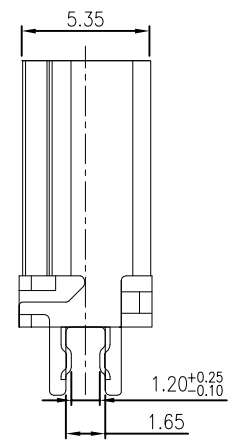

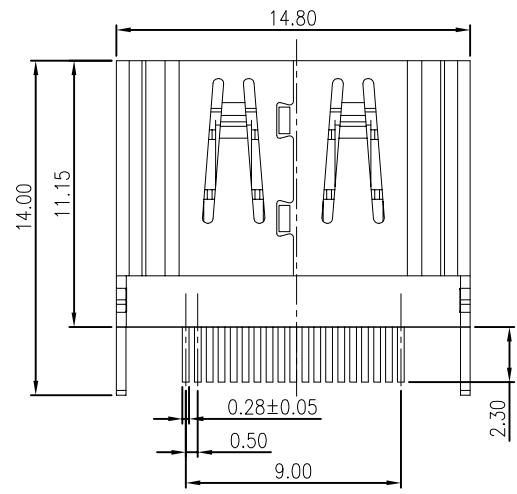
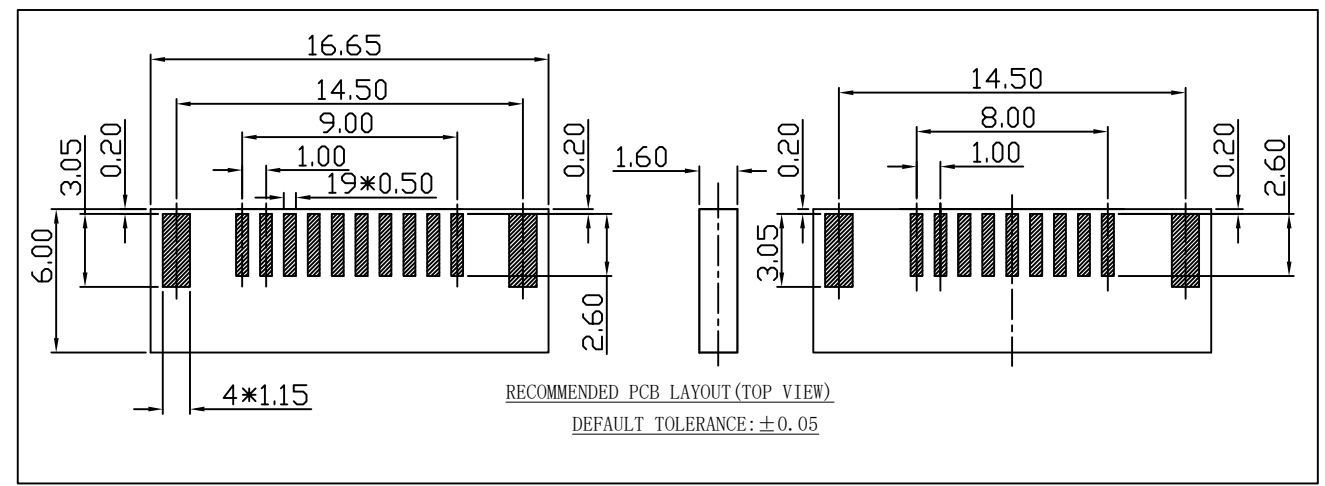
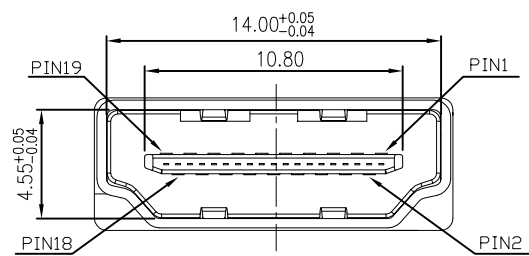

SPECIFICATION

- Electrical characteristics
 - Contact Current Rating: 0.5 A
 - Dielectric Withstanding Voltage: 300V AC
 - Insulation Resistance: a. Mate 100MΩ MIN at 500V/DC
b. Unmate 10MΩ MIN at 150V/DC
 - Contact Resistance: 30mΩ MAX
 - Temperature Range: -20° C to +85° C
- Mechanical
 - Mating Face: 44.1N MAX
 - Unmating Face: 9.8N MIN; 39.2N MAX
 - Durability: 5000 Cycles
- Material:
 - HOUSING: THERMOPLASTICS HIGH TEMP LCP+GLASS
FIBER BLACK COLOR, UL94V-0
 - CONTACT: Copper Alloy, T=0.20MM
 - SHELL: Copper Alloy (SPCC), T=0.40MM
- PLATING:
 - CONTACT: 1~30u" GOLD/TIN PLATING ON CONTACT AREA
100u" MIN, TIN PLATING ON SOLDER TAILS
 - 50u" MIN, NICKEL UNDERPLATING OVER ALL
 - SHELL: 80u", NICKEL UNDERPLATING OVER ALL



深圳市华德共创科技有限公司
Shenzhen Huade co-create Technology Co., LTD
电话: 0755-27111216 传真: 0755-29940187

-TOLERANCES- UNLESS OTHERWISE SPECIFIED 公差参数表		 		TITLE: HDMI AF夹板1.6铁壳0.4镀镍 产品名称: 黑胶弯端			
X.X ±0.30	X.X* ±3°	APPD: 核准:	PART NO: 产品编号: HDMI-GD-133PWB				
X.XX ±0.20	X.XX* ±2°	CHECK: 校对: 王建业	DATE	SCALE	UNIT	CODE NUMBER	
X.XXX ±0.10	X.XXX* ±1°	DRAW: 绘图: 黄艳兰	2016-03-12	1:1	mm	A001	