

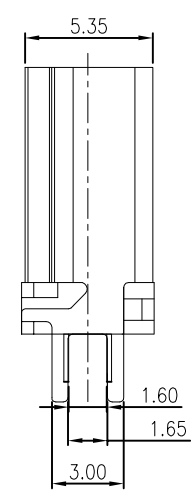

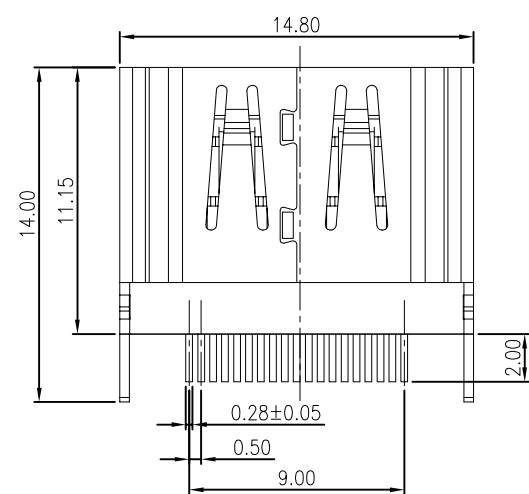

修订	标记	修改摘要	签名	日期
REV	MARK	REVISION DESCRIPTION	SIGNATURE	DATE
AO		NEW DWG		2016-03-12

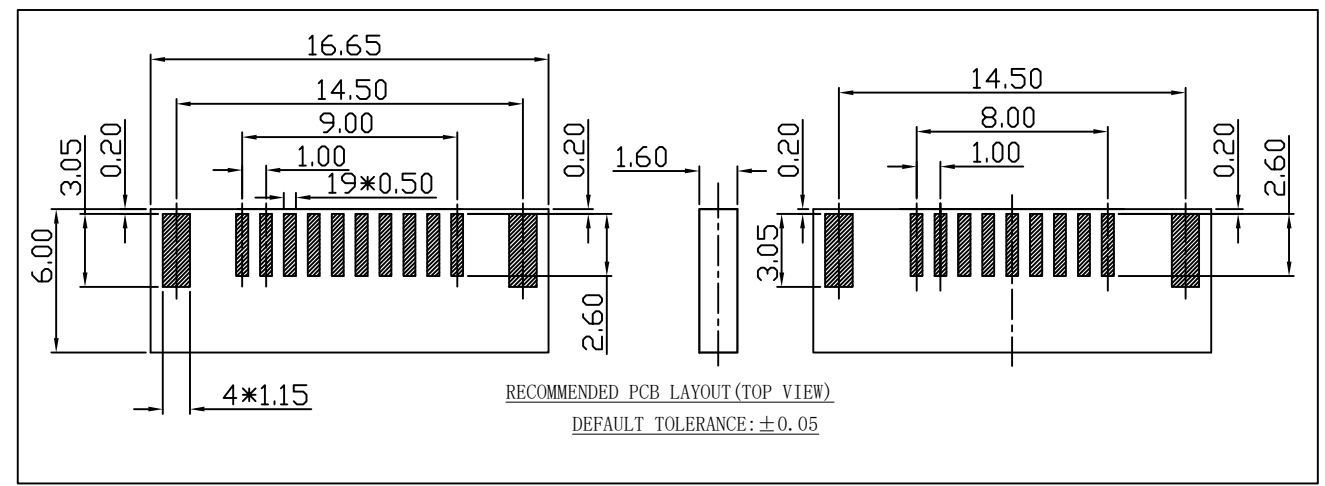
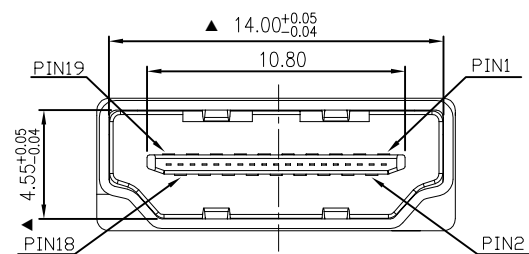

**SPECIFICATION**

- Electrical characteristics
  - Contact Current Rating: 0.5 A
  - Dielectric Withstanding Voltage: 300V AC
  - Insulation Resistance: a. Mate 100MΩ MIN at 500V/DC  
b. Unmate 10MΩ MIN at 150V/DC
  - Contact Resistance: 30mΩ MAX
  - Temperature Range: -20° C to +85° C
- Mechanical
  - Mating Face: 44.1N MAX
  - Unmate Face: 9.8N MIN; 39.2N MAX
  - Durability: 5000 Cycles
- Material:
  - HOUSING: THERMOPLASTICS HIGH TEMP LCP+GLASS  
FIBER BLACK COLOR, UL94V-0
  - CONTACT: Copper Alloy, T=0.20MM
  - SHELL: Copper Alloy (SPCC), T=0.40MM
- PLATING:
  - CONTACT: 1~30u" GOLD/TIN PLATING ON CONTACT AREA  
100u" MIN, TIN PLATING ON SOLDER TAILS
  - 50u" MIN, NICKEL UNDERPLATING OVER ALL
  - SHELL: 80u", NICKEL UNDERPLATING OVER ALL

		<b>深圳市华德共创科技有限公司</b> Shenzhen Huade co-create Technology Co., LTD 电话: 0755-27111216 传真: 0755-29940187			
-TOLERANCES- UNLESS OTHERWISE SPECIFIED 公差参数表		 		TITLE: HDMI AF夹板1.6铁壳0.4镀镍 产品名称: 黑胶针长2.0	
X.X ±0.30	X.X* ±3°	APPD: 核准:	PART NO: 产品编号: HDMI-GD-136PWB		
X.XX ±0.20	X.XX* ±2°	CHECK: 校对: 王建业	DATE	SCALE	UNIT
X.XXX ±0.10	X.XXX* ±1°	DRAW: 绘图: 黄艳兰	2016-03-12	1:1	mm
					CODE NUMBER A001