

THIS DRAWING IS UNPUBLISHED. RELEASED FOR PUBLICATION .1997
 © COPYRIGHT 1997 BY - ALL RIGHTS RESERVED.

REVISIONS					
P	LTR	DESCRIPTION	DATE	DWN	APVD
A2		Released as per ECR-07-030419	17.12.07	SP	TS
A3		Released as per ECR-18-004438	05APR2018	GCM	JB

NOTES

- 1 Material: Housing: Aluminium Diecasting Alloy
Seals: Neoprene
- 2 Surface:- varnish-grey
Aluminium oxide+
Varnish black
- 3 Varnish on the inside not necessary
- 4 Packaging quantity: 5 pieces in a box

PN 1-5 & 2-5

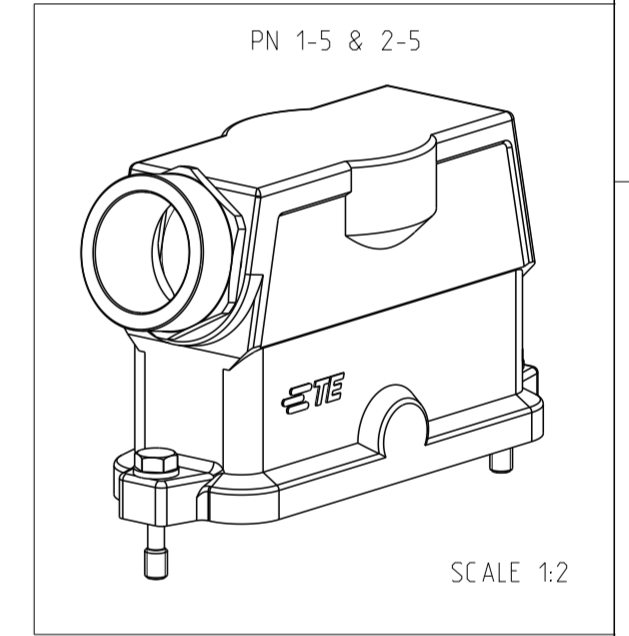
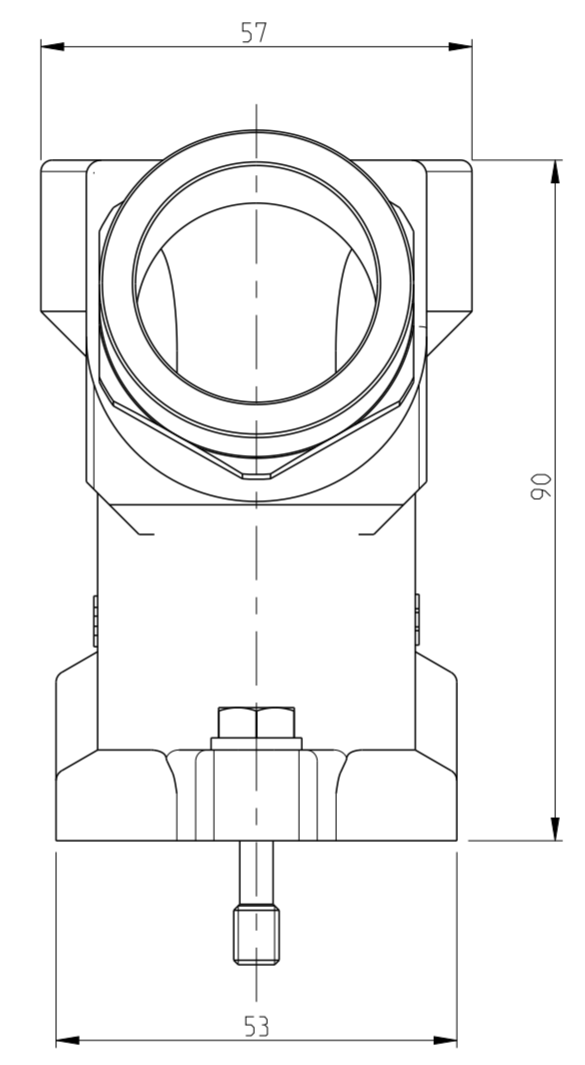
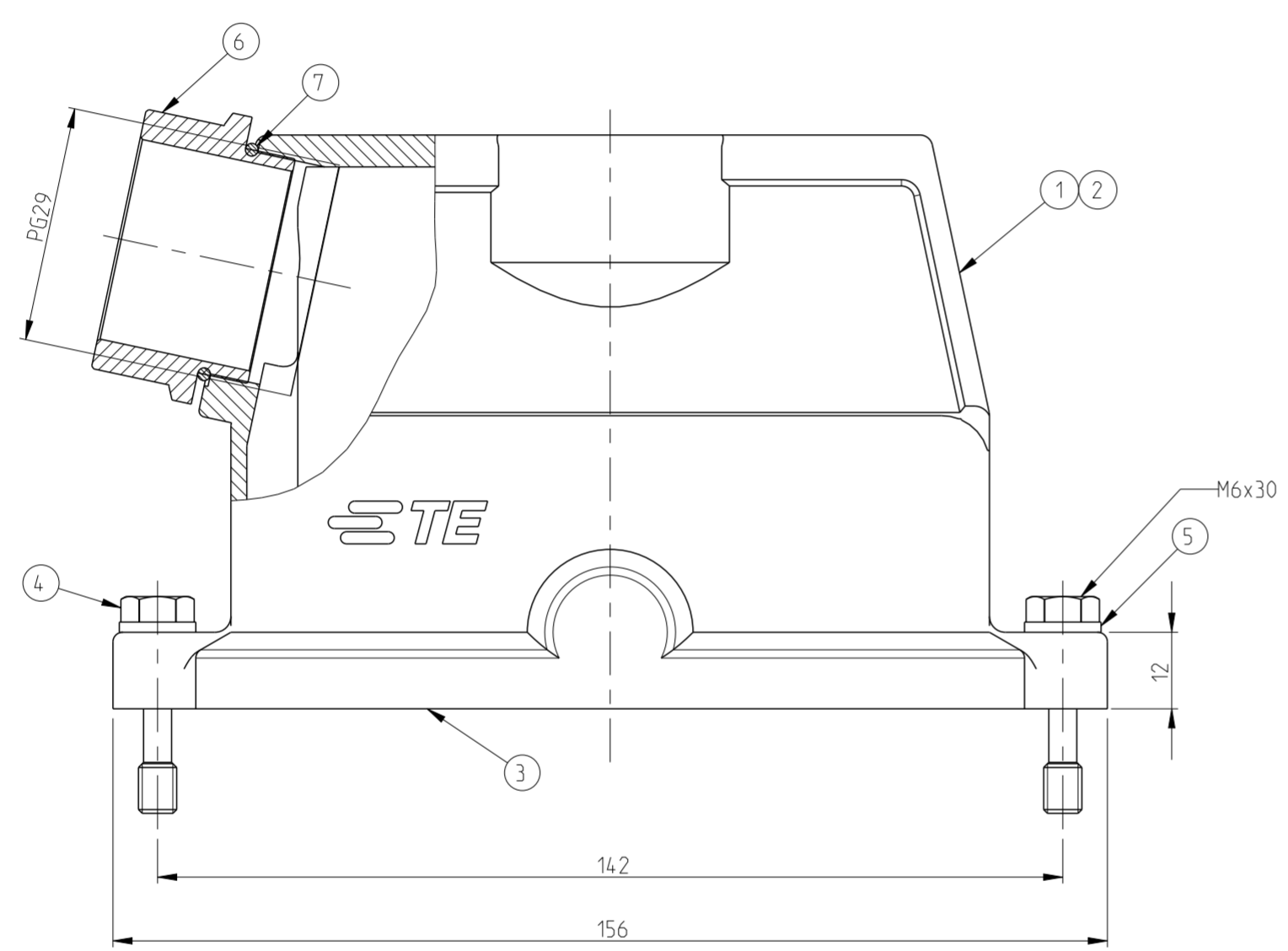

QTY	ITEM NO	DESCRIPTION	MATERIAL	SURFACE	COLOR	ITEM NO	REMARKS
1	1	O-Ring Pg 29	Neoprene	-	Black	7	
1	1	Adaptor Pg 29	Brass	Nickel plated	Blue	6	
2	2	Spring washer	Stainless steel	Blank	Blue	5	B6.4
2	2	Fixing screw	Stainless steel	Blank		4	M6x30
1	1	Seal Bg8	Neoprene	-	Black	3	-
1	1	Hood HIP-K	Aluminium	Aluminium oxide	Black	2	
1	1	Hood HIP	Aluminium	-	Grey	1	
2-5	1-5	DESCRIPTION	MATERIAL	SURFACE	COLOR	ITEM NO	REMARKS
ORDERING TEXT							
HIP.24/64.STS.1.29.Z							
HIP-K.24/64.STS.1.29.Z							

THIS DRAWING IS A CONTROLLED DOCUMENT.		DWN Schneider 07.11.02	TE Connectivity			
		CHK schweiger 07.11.02				
DIMENSIONS: mm		APVD -	NAME Hood HIP size8 HIP.24/64.STS.1.29. Z			
TOLERANCES UNLESS OTHERWISE SPECIFIED: 0 PLC ± 1 PLC ± 2 PLC ± 3 PLC ± 4 PLC ± ANGLES ± FINISH		PRODUCT SPEC 108-74030	SIZE A2			
MATERIAL		APPLICATION SPEC 114-74017	CAGE CODE 100779	DRAWING NO C-1102659		RESTRICTED TO
		WEIGHT	SCALE 1:1		SHEET 1 OF 1	REV A3
		CUSTOMER DRAWING				