

### Features

- Guaranteed 1.8V and 5.5V performance
- Rail-to-Rail Input and Output
- Low supply current 40μA/comparator Typ
- Open-Drain Output for Maximum Flexibility
- RoHS and Halogen free compliance
- package: SOT353(SC70-5),SOT23-5,SOP-8

### Applications

- Alarm and Monitoring Circuits
- Peak and Zero-crossing Detectors
- Logic Level Shifting or Translation
- Window Comparators
- IR Receivers
- Portable Systems

### General Description

The TECH PUBLIC INCORPORATED TPV331/TPV393 series are low-voltage,(1.8V to 5.5V) single and dual comparators, which are redesigned to effectively reduce cost and space at low-voltage levels.

### Pinout (top view)

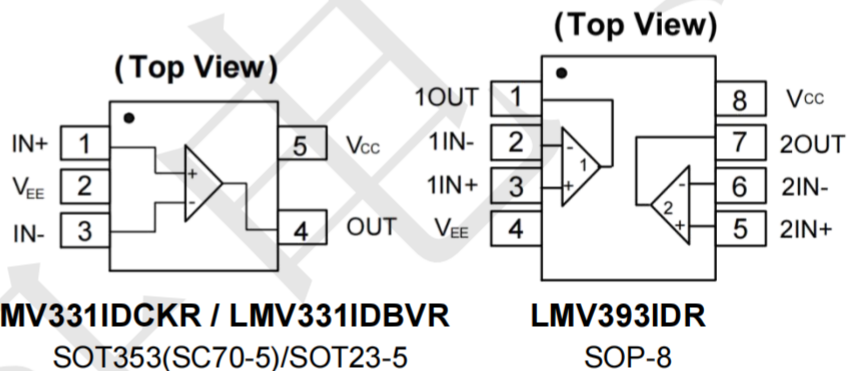

### Pin Configurations

LMV331IDCKR (SOT353) (SC70-5) / LMV331IDBVR (SOT23-5)		
Pin Number	Pin Name	Pin Function
1	IN+	Non-Inverting Input
2	VEE	Chip Supply Voltage(Negative)/GND
3	IN-	Inverting Input
4	OUT	Output
5	VCC	Chip Supply Voltage(Positive)
LMV393IDR (SOP-8)		
1	1OUT	Channel 1 Output
2	1IN-	Channel 1 Inverting Input
3	1IN+	Channel 1 Non-inverting Input
4	VEE	Chip Supply Voltage(Negative)/GND
5	2IN+	Channel 2 Non-inverting Input
6	2IN-	Channel 2 Inverting Input
7	2OUT	Channel 2 Output
8	VCC	Chip Supply Voltage(Positive)

## Absolute Maximum Ratings

(@TA = +25°C, unless otherwise specified.)

		Rating	UNIT	
VID	Differential Input Voltage	±Supply Voltage	V	
VCC -VEE	Supply Voltage	5.5	V	
θJA	Thermal Resistance	SOT353(SC70-5)	333	
	Junction-to Ambient	SOT23-5	190	
		SOP-8	125	
LT	Lead Temperature (Soldering, 10 sec.)	260	°C	
Temperature	Junction Temperature , TJ	-40		125
	Storage, Tstg	-65		150
HBM	ESD Susceptibility	4000	V	
MM		300		

## BLOCK DIAGRAM

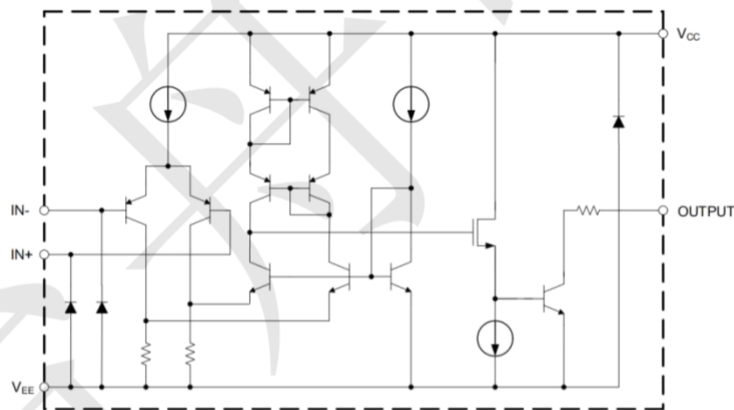

## Power Supply Bypassing

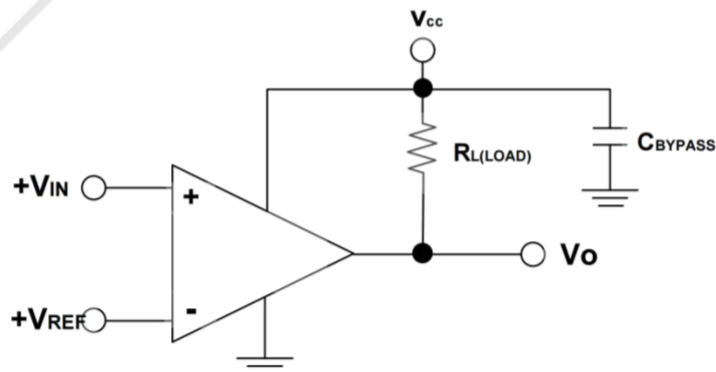

For better performance, power supply bypass capacitor is necessary. For a single-supply operation system, a minimum of 0.1μF bypass capacitor should be recommended to place as close as possible between VCC pin and GND.

## Typical Application Circuit

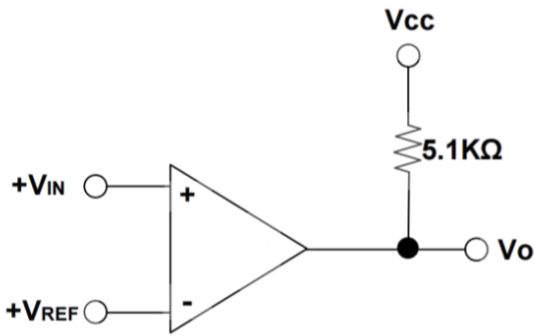

Basic Comparator

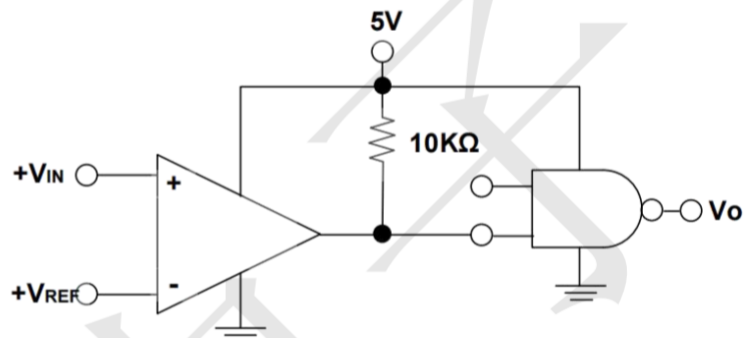

Driving CMOS/TTL

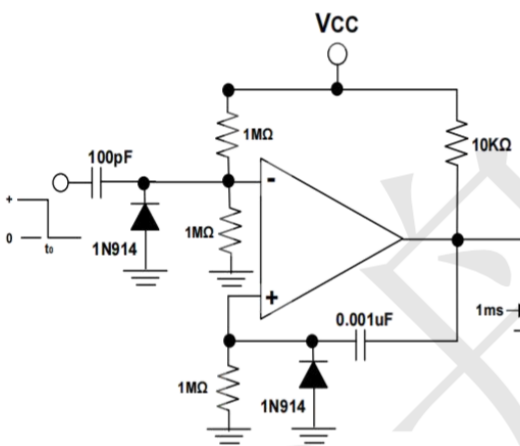

One-Shot Multivibrator

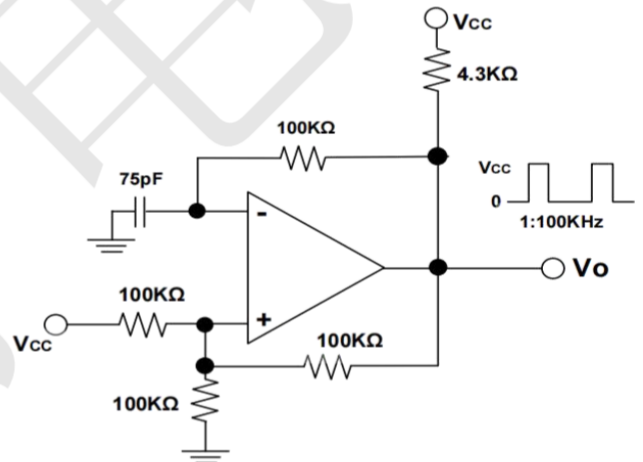

Squarewave Oscillator

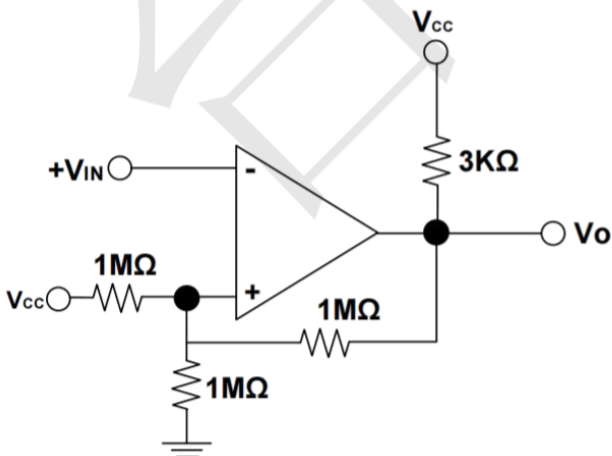

Inverting Comparator with Hysteresis

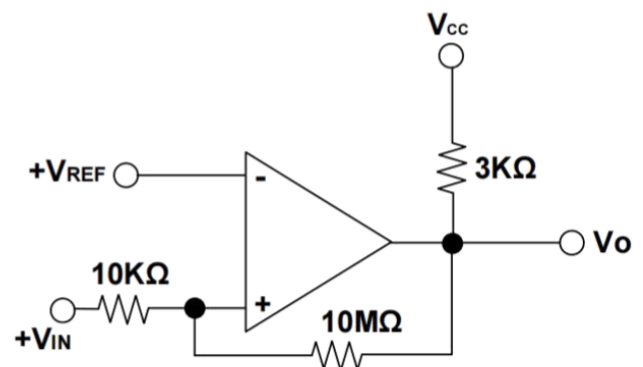

Non-Inverting Comparator with Hysteresis

### Electrical Characteristics

(At  $V_S = +5V$ ,  $V_{CM} = 0V$ ,  $C_L = 15pF$ , and  $T_A = +25^\circ C$ , unless otherwise noted.)

PARAMETER	SYMBOL	TEST Conditions	MIN	TYP	MAX	UNIT
Operating Voltage Range	$V_{CC}$		1.8	--	5.5	V
Quiescent Current / Comparator	$I_Q$		--	40	70	$\mu A$
Input Offset Voltage	$V_{OS}$		--	0.5	3	mV
Input Offset Voltage Tempco	$\Delta V_{OS}/\Delta T$		--	2	--	$\mu V/^\circ C$
Input Bias Current	$I_B$		--	6	--	PA
Input Offset Current	$I_{OS}$		--	4	--	PA
Common-Mode Voltage Range	$V_{CM}$	$V_S = 5.5V$	--	-0.1 to +5.6	--	V
Common-Mode Rejection Ratio	CMRR	$V_S = 5V, V_{CM} = 0V$ to 5V	--	70	--	dB
Power-Supply Rejection Ratio	PSRR	$V_S = +1.6V$ to +5.5V, $V_{CM} = 0V$	--	75	--	dB
Input Hysteresis	$V_{HYS}$		--	6	--	mV
Output Voltage Swing from Rail	$V_{OH}$	$V_S = 5V, I_O = 1mA$	--	$V_S - 0.05$	$V_S - 0.3$	V
	$V_{OL}$		--	57	300	mV
Output Short-Circuit Current	$I_{SINK}$	$V_S = 5V, Out$ to $V_S/2$	--	33	--	mA
Propagation Delay (Low to High)	$T_{DLH}$	$V_S = 3V, Overdrive = 100mV$	--	120	--	ns
Propagation Delay (High to Low)	$T_{DHL}$		--	250	--	ns
Rise Time	$T_r$		--	5	--	ns
Fall Time	$T_f$		--	5	--	ns

#### Notes:

1. Typical values represent the most likely parametric norm as determined at the time of characterization. Actual typical values may vary over time and will also depend on the application and configuration. The typical values are not tested and are not guaranteed on shipped production material.
2. All limits are guaranteed by testing or statistical analysis.

### Typical Performance Characteristics (@ $T_A = +25^\circ\text{C}$ , unless otherwise specified.)

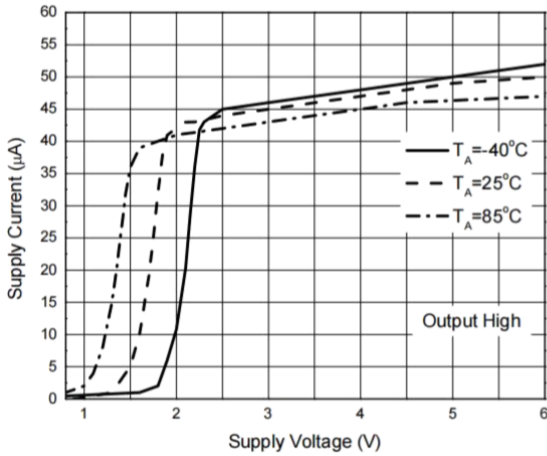

Supply Current vs. Supply Voltage (TPV331)

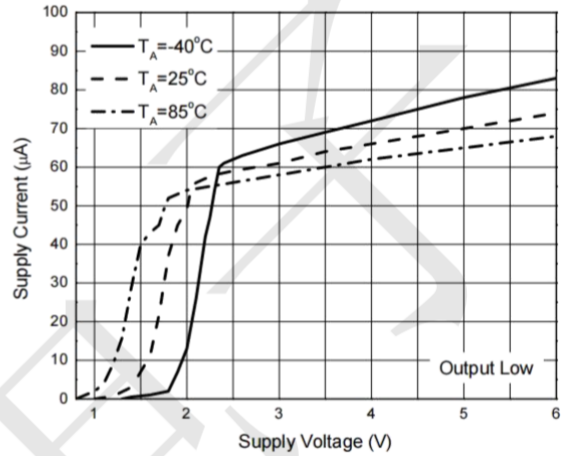

Supply Current vs. Supply Voltage (TPV331)

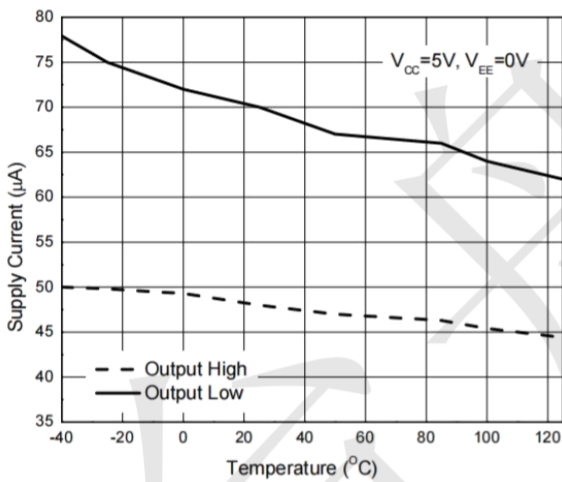

Supply Current vs. Temperature (TPV331)

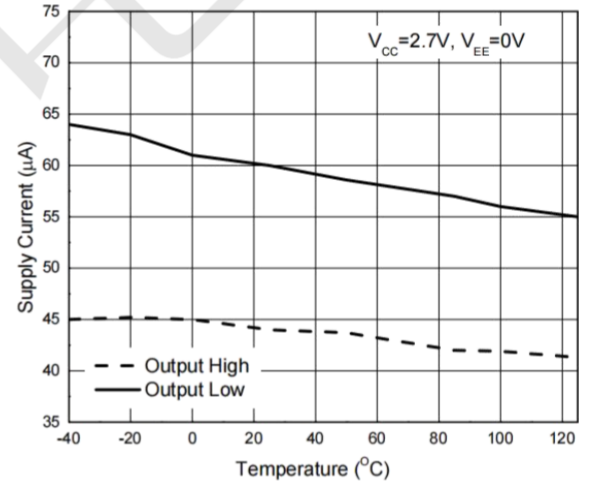

Supply Current vs. Temperature (TPV331)

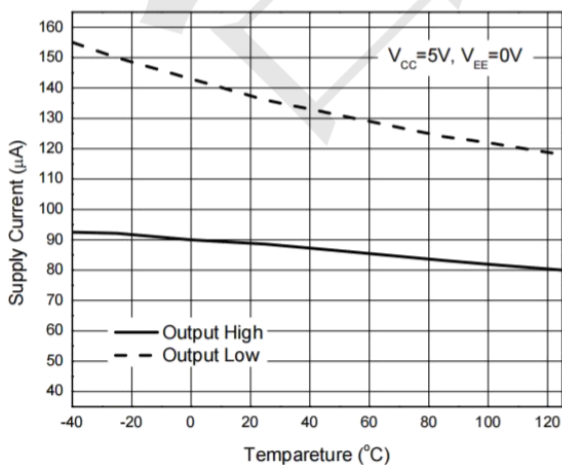

Supply Current vs. Temperature (TPV393)

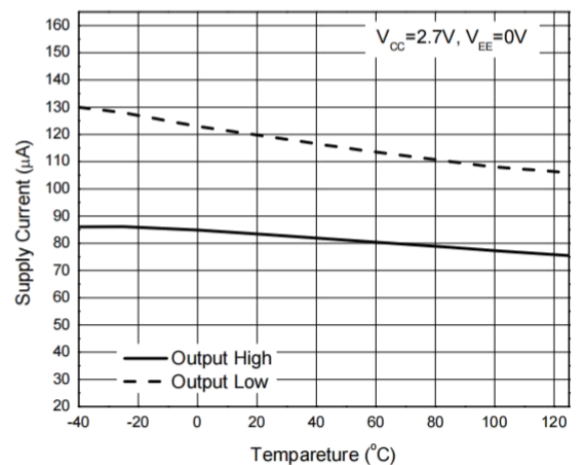

Supply Current vs. Temperature (TPV393)

### Package information

#### SOT23-5

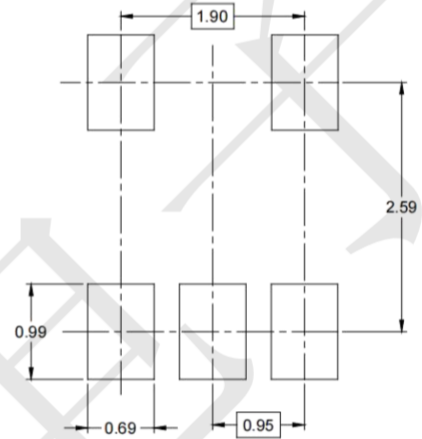
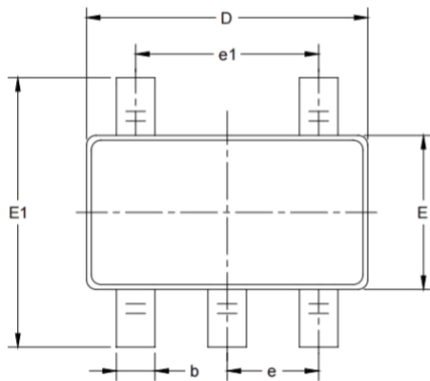

RECOMMENDED LAND PATTERN (Unit: mm)

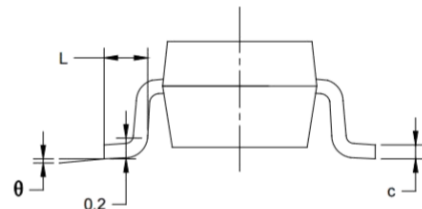
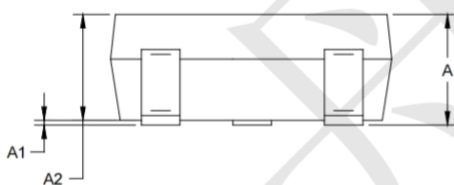

Symbol	Dimensions In Millimeters		Dimensions In Inches	
	MIN	MAX	MIN	MAX
A	1.050	1.250	0.041	0.049
A1	0.000	0.100	0.000	0.004
A2	1.050	1.150	0.041	0.045
b	0.300	0.500	0.012	0.020
c	0.100	0.200	0.004	0.008
D	2.820	3.020	0.111	0.119
E	1.500	1.700	0.059	0.067
E1	2.650	2.950	0.104	0.116
e	0.950 BSC		0.037 BSC	
e1	1.900 BSC		0.075 BSC	
L	0.300	0.600	0.012	0.024
θ	0°	8°	0°	8°

**Package information**

SOT353(SC70-5)

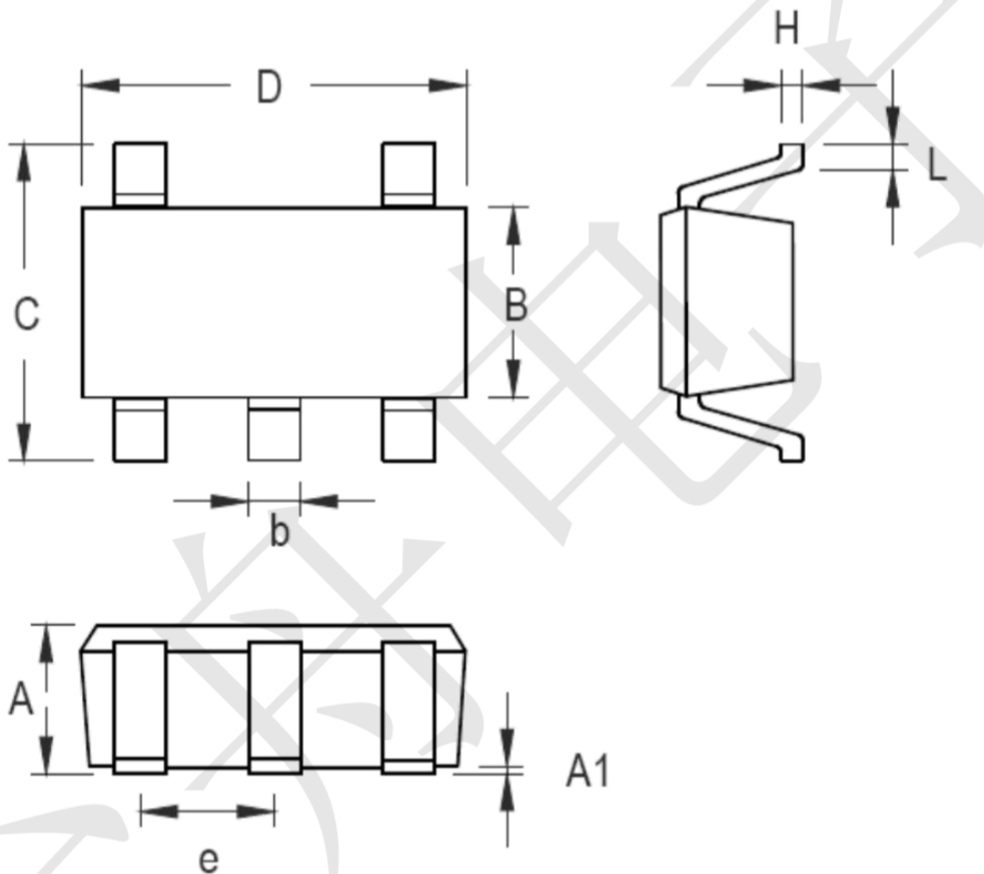

Symbol	Dimensions In Millimeters		Dimensions In Inches	
	Min	Max	Min	Max
A	0.800	1.100	0.031	0.044
A1	0.000	0.100	0.000	0.004
B	1.150	1.350	0.045	0.054
b	0.150	0.400	0.006	0.016
C	1.800	2.450	0.071	0.096
D	1.800	2.250	0.071	0.089
e	0.650		0.026	
H	0.080	0.260	0.003	0.010
L	0.210	0.460	0.008	0.018

## Package information

### SOP-8

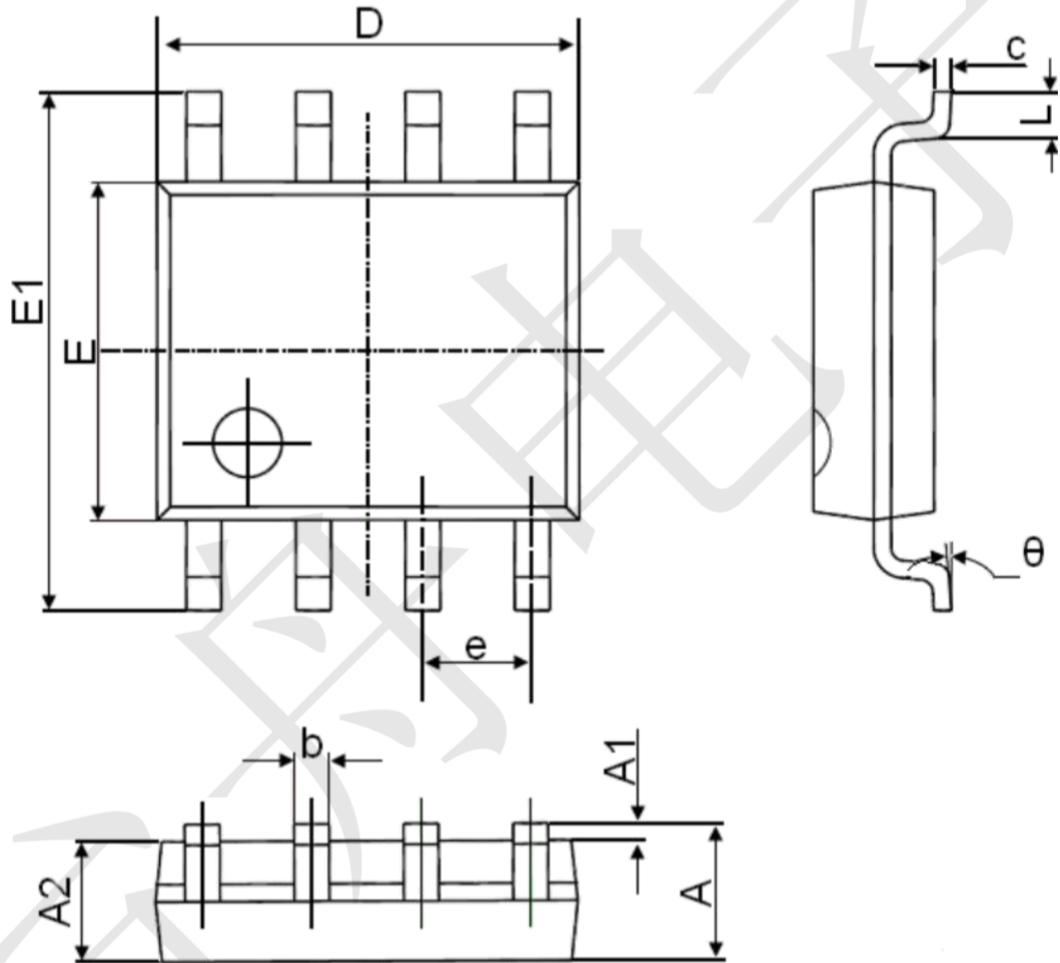

Symbol	Dimensions In Millimeters		Dimensions In Inches	
	Min.	Max.	Min.	Max.
A	1.350	1.750	0.053	0.069
A1	0.100	0.250	0.004	0.010
A2	1.350	1.550	0.053	0.061
b	0.330	0.510	0.013	0.020
c	0.170	0.250	0.006	0.010
D	4.700	5.100	0.185	0.200
E	3.800	4.000	0.150	0.157
E1	5.800	6.200	0.228	0.244
e	1.270(BSC)		0.050(BSC)	
L	0.400	1.270	0.016	0.050
θ	0°	8°	0°	8°