

REV	MARK	修改摘要	签名	日期
AO		NEW DWG		2016-03-12

- SPECIFICATION:
1. RATING: DC 60V 5A
  2. CONTACT RESISTANCE: 30mΩ MAX.
  3. INSULATION RESISTANCE: 100 MΩ MIN.
  4. WITHSTAND VOLTAGE: 500 VAC
  5. INSERTION FORCE: 30N MAX.
  6. EXTRACTION FORCE: 6N MIN.
  7. DURABILITY: 5,000 CYCLES

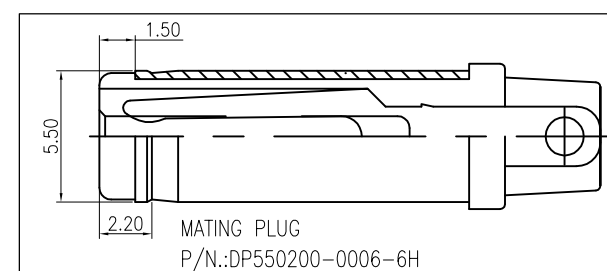

NO.	DESCRIPTION	MATERIAL	REMARKS	QTY
F	PLATE	BRASS	Sn 60u" MIN./Ni 50u" MIN.	1
E	SHUNT	BRASS	Sn 60u" MIN./Ni 50u" MIN.	1
D	SPRING	COPPER ALLOY	Au 1u" ON THE CONTACT AREA Sn 60u" MIN. ON THE SOLDER TAIL Ni 50u" MIN. UNDER PLATED OVERALL	1
C	CENTER PIN	BRASS	Au 1u"/Ni 50u" MIN.	1
B	COVER	LCP	BLACK	1
A	HOUSING	LCP	BLACK	1

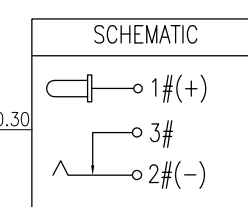
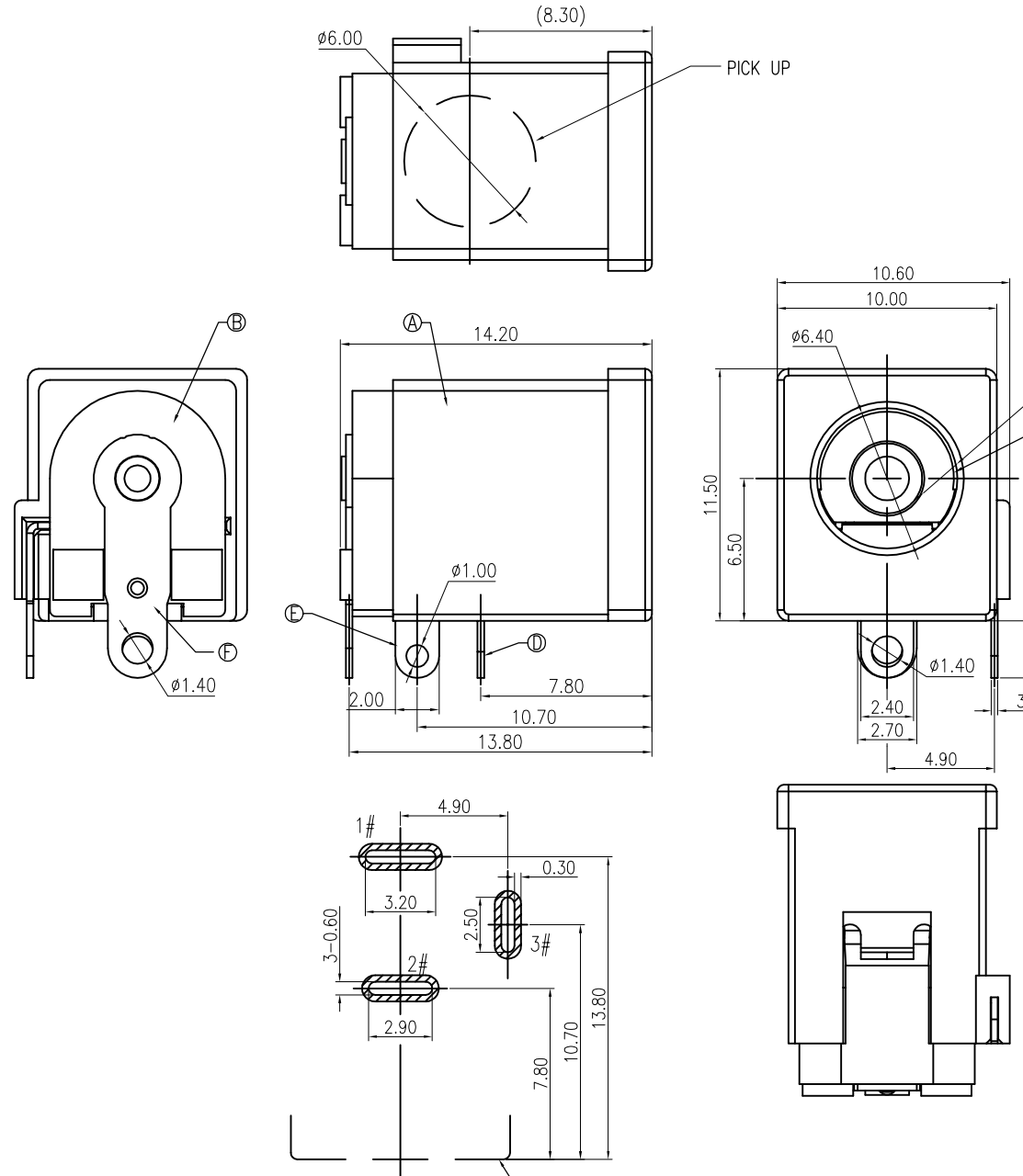

深圳市华德共创科技有限公司  
Shenzhen Huade co-create Technology Co.,LTD  
电话: 0755-27111216 传真: 0755-29940187

RECOMMENDED PCB LAYOUT  
TOP VIEW TOLERANCE: ±0.05

-TOLERANCES- UNLESS OTHERWISE SPECIFIED 公差参数表		TITLE: DC Power Jack 5521 大电流5A, 卧式, 产品名称: 高可靠 CL=6.5	
X.X	±0.30	X.X*	±3°
X.XX	±0.20	X.XX*	±2°
X.XXX	±0.10	X.XXX*	±1°
APPD: 核准:	王建国	PART NO: 产品编号:	DC550200-1095-2H
CHECK: 校对:	黄艳兰	DATE	SCALE
DRAW: 绘图:	2016-03-12	UNIT	CODE NUMBER
	1:1	mm	A001