

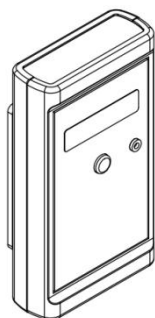

QUICK 499D Digital Surface Impedance Tester

Instruction Manual



Thank you for purchasing our products. Please keep the instruction manual properly for future reference.

Contents

1. Safety Instructions.....	1
2. Overview.....	1
3. Product Characteristics.....	2
4. Product Specifications.....	2
5. Functional Descriptions.....	3
5.1. Dimensions.....	3
5.2. Part Descriptions.....	4
6. Operation.....	4

1.Safety Instructions



CAUTION

- During the installation and use of this product, all electrical safety regulations of the country and regions must be strictly observed.
- If the product does not work properly, please contact the supplier or our company, and do not disassemble or change the product in any way. We are not responsible for any problems caused by unauthorized maintenance or modification.



WARNING

- Don't install the product in a place where the surface is easy to shake or be impacted, as it may damage the product.
- Don't install the product in places where it may be exposed to rain or moisture.
- The product should be used away from places where there is magnetic interference
- Don't use in flammable and explosive environments.
- Please do not hit the sensor sensing part.
- Please unplug the power cord when the product is not used for a long time.

2.Overview

The surface impedance tester can measure the surface resistance coefficient and grounding resistance of object, as well as the anti-static and insulating material. It adopts ASTM standard D-257 parallel electrode sensing method and uses high-precision OP-AMP integrated amplifier for automatic measurement.

This product complies with ANSI/ESD STM11.11 standard for Protection

of Electrostatic Discharge Sensitive Objects. Measurement of surface resistance of static dissipative planar materials.

3.Product Characteristics

- Measure the surface resistance coefficient and grounding resistance of the object, such as the anti-static and insulating material.
- Digital display, high accuracy.
- Small size, light weight, easy to use and reliable.

4.Product Specifications

Product Model	499D
Power Supply	DC 9V Battery
Measuring Range	$10^3 \sim 10^{12}$
Resolution	0.1 Digit
Accuracy	$\pm 10\%$
Operating Environment	$0 \sim 50^\circ\text{C}$, RH < 80%
Dimensions(L*W*H)	73*130*35mm
Weight	About 0.2kg

5.Functional Descriptions

5. 1. Dimensions

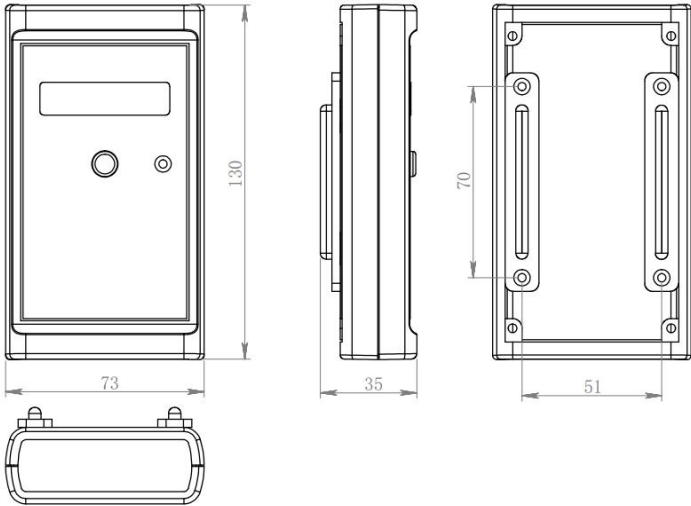

Unit: mm

5. 2. Part Descriptions

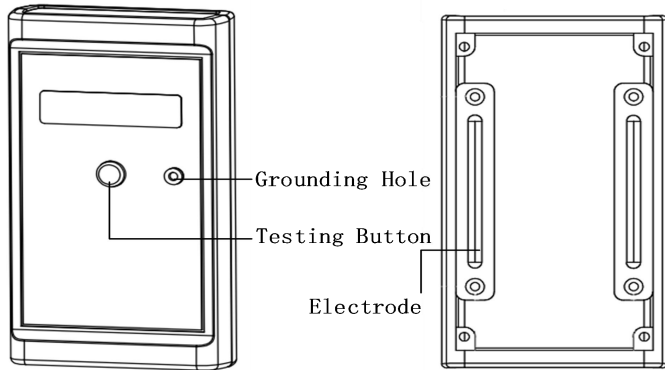

6. Operation

- 1) **Measure the surface resistance coefficient:** Place the tester on the surface of the testing object, press the testing button and it will display the surface resistance coefficient of the testing object, unit is ohm/ \square

LED display value meaning:

bAtL: Press the power switch, if the LED displays “bAtL”, indicating that the battery voltage is low and the battery needs to be replaced.

CALE: Press the power switch, if the LED displays “CALE”, indicating that the tester is not calibrated or the calibration is wrong and needs to be recalibrated. If it is still not calibrated, the tester will read the default data, and the test accuracy will be reduced.

Lr: The testing resistance is less than 300 ohms ($3 \times 10^2 \Omega$).

Hr: The testing resistance is more than 2T ohms ($2 \times 10^{12} \Omega$) .

x.xEXX: X is the resistance value of the testing object. X times 10 to the XX power ohm/ \square .

For example: LED displays 5.6E10, it represents $5.6 \times 10^{10} \Omega / \square$. ohms/ \square (sheet resistance) is the resistance between any opposite sides of a square area with a constant thickness.

2) Measure the grounding resistance: Insert one end of the testing wire into the grounding socket on the tester (the electrode inside the right side of the tester is disconnected), and the other end is clamped on a reliable connecting ground, then place the tester on the surface of the testing object and press the testing button. In this way, the measured data is the grounding resistance of the measured object rather than the surface resistance coefficient.

Note: *Ensure that the testing object surface is clean. Ensure good contact with the test electrode of the tester by applying appropriate pressure.

*The tester will automatically shut down after releasing the button for about 5S.

Warranty Card

●The warranty period of this product is calculated from the date of Purchase. During the warranty period, if the product breaks down during normal use, show the original warranty card and enjoy free service in the authorized repair company(or our company). Please keep the purchase certificate and this warranty card and show it before maintenance.

●During the warranty period, the following repairs need to be paid:
a.Unable to offer valid warranty card or certificate;
b.The purchase date, sales company and other items are not completely filled or the warranty card is altered;
c.Damage caused by failure to follow the use methods and precautions in the manual;
d.Damage caused by disassembly, repair and modification of products without authorization of the manufacturer;
e.Replacement of vulnerable and consumable parts.

●All items of the warranty card shall be completely filled in by the agent or user to obtain a 12-month warranty period.
●Please keep this warranty card properly It will not be re-offered after.

QUICK INTELLIGENT EQUIPMENT
CO., LTD.
ADD: NO.11, FengXiang Road, Wujin
High-Tech Industrial Development
Zone, Jiangsu, China
TEL: 86-519-86225678
FAX: 86-519-86558599
POSTCODE: 213167
WEBSITE: www.quick-global.com

Warranty Card

Type: _____

Model No.: _____

Serial No.: _____

Delivery Date: _____

Warranty File Card

Type: _____

Model No.: _____

Serial No.: _____

Delivery Date: _____

Address : _____

Postcode: _____

Telephone: _____

Contact Person: _____

QUICK INTELLIGENT EQUIPMENT CO., LTD.

ADD: NO.11, FengXiang Road, Wujin
High-Tech Industrial Development Zone,
Jiangsu, China

TEL: 86-519-86225678

FAX: 86-519-86558599

POSTCODE: 213167

WEBSITE: www.quick-global.com

