

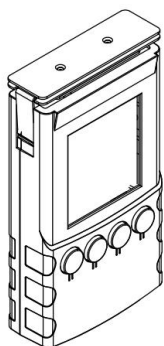

QUICK 431 Static Meter

Instruction Manual



Thank you for purchasing our products. Please keep the instruction manual properly for future reference.

Contents

1. Safety Instructions.....	1
2. Overview.....	1
3. Product Characteristics.....	2
4. Product Specifications.....	2
5. Functional Descriptions.....	3
5.1. Dimensions.....	3
5.2. Part Descriptions.....	4
5.3. Descriptions of the Display Interface	5
6. Working Modes.....	6
7. Zero Calibration.....	7
8. Switch Electrostatic and Ion Balance Measurement.....	8
9. HOLD/MAX Function.....	8
10. Electrostatic Measurement Method.....	9
11. Ion Balance Measurement Method.....	11
12. Replace the Battery.....	12

1. Safety Instructions



CAUTION

- During the installation and use of this product, all electrical safety regulations of the country and regions must be strictly observed.
- If the product does not work properly, please contact the supplier or our company, and do not disassemble or change the product in any way. We are not responsible for any problems caused by unauthorized maintenance or modification.



WARNING

- The product should be used away from places where there is magnetic interference.
- Don't install the product in a place where the surface is easy to shake or be impacted, as it may damage the product.
- Don't install the product in places where it may be exposed to rain or moisture.
- Don't use in flammable and explosive environments.
- Do not hit the sensing part of the sensor.
- When the tester is not in use, please turn off the power to prolong its life.

2. Overview

This tester is a special instrument for measuring static electricity and has the function of ion balance measurement. The tester uses new type of non-contact surface potential sensor, which can effectively measure the amount of static electricity carried by objects, such as plastics, chemical fibers, fur and human body.

The tester is simple to use and easy to carry, and is an indispensable measuring tool in the process of anti-static and electrostatic treatment.

3. Product Characteristics

- Four working modes available.
- Two measurement functions: a) electrostatic measurement b) ion balance voltage measurement.
- Easy to use, convenient test distance positioning.
- Pocket-size design, portable.

4. Product Specifications

Model	431
Power supply	DC 9V battery
Display	LCD
Electrostatic measuring range	Low range: 0- ± 1.50 KV High range: 1- ± 22.0 KV Auto switch of high and low
Ion balance measuring range	0~±220V
Standard measuring distance	25mm (±0.5mm)
Standby current	<3uA
Working current	<15mA
Operation ambient	0 °C - 50 °C, RH: 0 % -80%
Dimensions(L*W*H)	71*132*27mm
Weight	About 0.2 kg

5. Functional Descriptions

5. 1. Dimensions

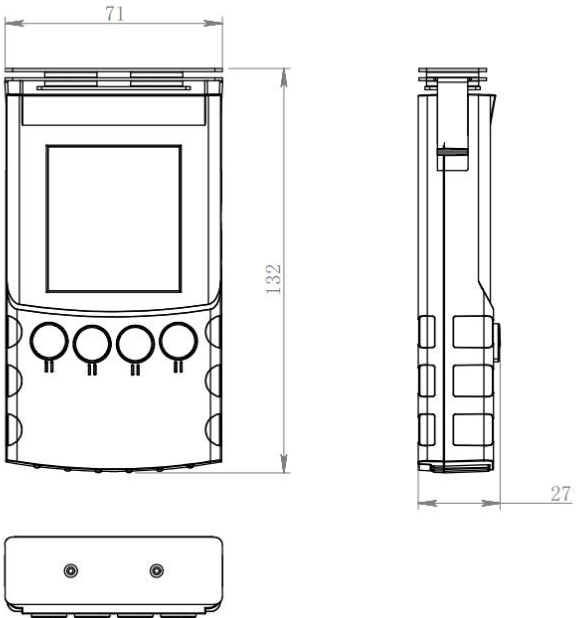

Unit: mm

5. 2. Part Descriptions

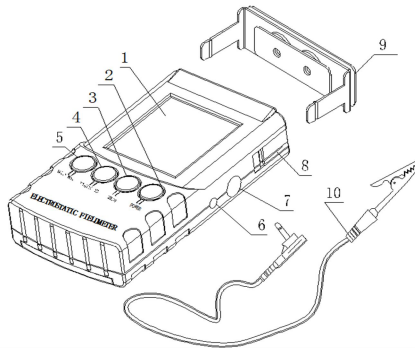

NO.	Part Descriptions
1	LCD display
2	POWER button
3	ZERO button
4	STATIC/IB button
5	HOLD/MAX button
6	Calibration hole
7	Tester grounding jack
8	Ion balance measuring board slot
9	Ion balance measuring board
10	Grounding wire

5. 3. Descriptions of the Display Interface

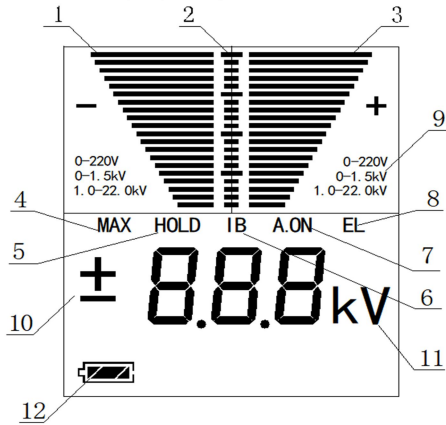

NO.	Descriptions
1	Negative rank
2	Coordinate
3	Positive rank
4	Max function
5	Hold function
6	Measure ion balance
7	Continuous working state
8	LCD backlight
9	Range display
10	Measuring data
11	Unit
12	Battery power

6. Working Modes

Press and hold the power key, and four working modes will display in turn for selection (as shown in the sheet below).

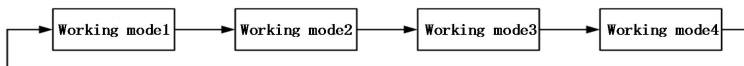

	Working mode 1	Working mode 2	Working mode 3	Working mode 4
Time to press the Power button	1s-2.5s	2.5s-3.5s	3.5s-4.5s	4.5s-5s
LCD	Displays "1"	Displays "2" and "EL"	Displays "3" and "A.ON"	Displays "4", "EL" and "A.ON"
Sound	One beep	One beep	Three beeps	Three beeps
Mode status	Auto shutdown after 5mins of operation		Continuous operation, no auto shutdown(A.ON)	
	Backlight off	Backlight on(EL)	Backlight off	Backlight on (EL)

Manual shutdown: when the tester is in the working state, press the "POWER" button, and the screen will display "OFF" to shut down.

7. Zero Calibration

Note:

***Tester ground:** refers to the internal default 0 value of the tester.

A. The grounding wire inserted into the grounding jack of the tester is the tester grounding.

B. The tester housing is made of anti-static material, connect it with the tester ground, so the tester housing is also the tester ground.

*** Conductor:** because of the high impedance of the tester, so relatively speaking, the human body, water, wet objects, land, some wall and floor tiles, etc. are conductors.

*** Grounding:** refers to the connection with the ground. **Tester ground:** refers to the tester ground is connected to the grounding object. **The grounded object is an object that is connected to the ground, like: tile of certain wall floor, certain job chair, the human body wears anti-static shoes,etc.**

1) The tester needs to be zeroed before measuring the electrostatic or ion balance.

2) There are three zero calibration methods for electrostatic measurement:

- ① Connect the tester to the ground, measure the object known as the ground, and then press and hold the ZERO button for about 2 seconds, then release it, you will hear a "beep" sound and a value of "0" will be displayed, indicating that the zero calibration is successful.
- ② Connect the tester to the ground, keep the front end away from charged objects, press and hold the ZERO button for about 2 seconds, then release it, you will hear a "beep" sound and a value of "0" will be displayed, indicating that the zero calibration is successful.
- ③ Connect the conductor to the ground of the tester, measure the conductor, and then press and hold the ZERO key for about

2 seconds, then release it, you will hear a "beep" sound and a value of "0" will be displayed, indicating that the zero calibration is successful.

For example, one hand holds the tester, and the other hand can be used as a conductor to be placed at the front end of the tester for zero calibration.

3) Zero calibration of ion balance measurement: plug in the ion balance measuring plate, connect the front measuring plate to the ground of the tester, and then press and hold the ZERO button for about 2 seconds, then release it, you will hear a "beep" sound and a value of "0" will be displayed, indicating that the zero calibration is successful.

8.Switch Electrostatic and Ion Balance Measurement

- 1) After the power is connected, it will automatically enter the electrostatic measuring state (STATIC);
- 2) Press the STATIC/IB button to enter the ion balance measuring state ("IB" is displayed on the screen);

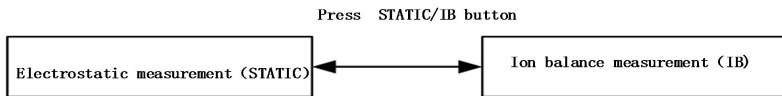

- 3) Press STATIC/IB again to return to the electrostatic measuring status;
- 4) Press the STATIC/IB button, enter the ion balance measuring state again, and cycle through this.

9.HOLD/MAX Function

- 1) HOLD function: holds the current measured value for reading or recording the value. After entering the HOLD function, "STATIC/IB" button and "ZERO" button are locked and will not work until exiting the HOLD state.

Enter: press the HOLD/MAX button (less than 1.5S) to enter the HOLD function ("HOLD" displays on the screen after the button pops up).

Exit: press the HOLD/MAX button to exit the HOLD function ("HOLD" disappears on the screen).

2) MAX function: the tester will display the captured maximum value and lock the value until it is updated when the maximum value is captured again. In the MAX function state, "STATIC/IB" button and "ZERO" button are locked and will not work until exiting the MAX state.

Enter: press the HOLD/MAX button, enter MAX function until "MAX" displays on the screen.

Exit: press the HOLD/MAX button to exit the MAX function("MAX" disappears on the screen)

10.Electrostatic Measurement Method

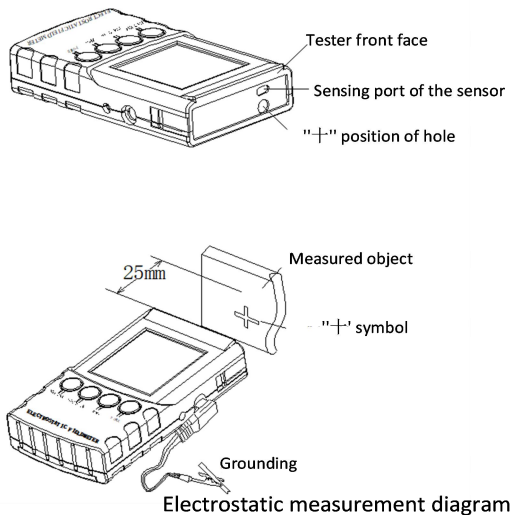

1) Press "POWER" button, select working modes and turn on the power, enter the electrostatic measuring mode.

2) Grounding the tester.

3) The front face of the tester shall be kept away from charged objects. If the display of the tester is not zero, zero calibration is required.

△Note: The measuring accuracy of the tester is related to the distance from the ion balance back end measuring plate to the sensing port of the sensor, so the ion balance measuring plate must be inserted in place as required.

4) The front face of the tester is parallel to the measured object and keeps a distance of 25mm, when there is a clear red "+" on the surface of the tested object during the measurement, the measuring distance is about 25mm. At this time, the value displayed on the LCD is the electrostatic value carried by the surface of the measured object.

5) To keep the current testing value or capture the peak value, press " HOLD/MAX" button to enter "HOLD" or "MAX" state.

6) Press the "POWER" button to shut down when it is not in use.

△Note: The measurement accuracy of the tester is related to the measuring distance of 25mm. The clearer the "+" character on the surface of the measured object is, the closer the measuring distance is to 25mm.

11. Ion Balance Measurement Method

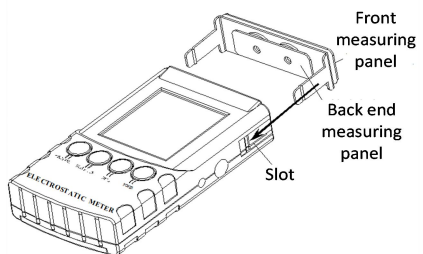

Insert the ion balance measuring plate into the tester slot

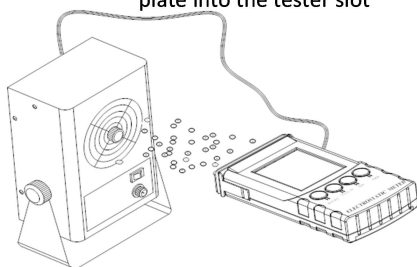





Ion balance measurement diagram

- 1) Insert the ion balance measuring plate into the tester slot (in the direction shown in the figure), and it must be inserted to the end.
- 2) Press "POWER" button and select working mode. After entering the electrostatic measuring mode, press the "STATIC/IB" button to enter the ion balance measuring state.
- 3) Connect the front measuring panel to the tester ground. If the display is not zero, calibrate zero (refer to 7 for specific method)
- 4) Connect the tester ground to the static elimination equipment ground.
- 5) Aligning the tester with the anti-static equipment (such as static eliminator, ionizing air snake and etc.) and keeping a certain distance, then the ion balance of the anti-static equipment can be measured.
- 6) To keep the current testing value or capture the peak value, press "HOLD/MAX" button to enter "HOLD" or "MAX" state.

7) Press the "POWER" button to shut down when it is not in use.

⚠Note: Please do not touch the ion balance measuring plate during the test, otherwise the voltage on the front measuring plate will be discharged instantaneously.

12. Replace the Battery

- 1)  indicating full power,  indicating sufficient power,  indicating weak power,  indicating run of power.
- 2) When the battery is under-voltage or no power, the tester cannot be turned on normally. When the tester is working and the battery is under-voltage or no power, it will give an alarm and then shut down automatically. At this time, the battery needs to be replaced before it works normally.
- 3) Replace the battery: remove the battery cover on the back of the tester, take off the old battery from the battery buckle, install the new battery, put it into the battery box, and cover the battery cover (as shown in the figure below).

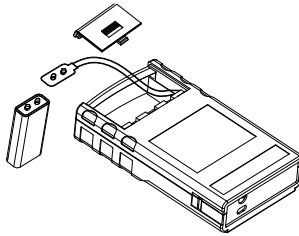

⚠Note: *Please turn off the power when not testing.

*** Do not replace the battery while the tester is working to avoid damaging the tester.**

Warranty Card

●The warranty period of this product is calculated from the date of Purchase. During the warranty period, if the product breaks down during normal use, show the original warranty card and enjoy free service in the authorized repair company(or our company). Please keep the purchase certificate and this warranty card and show it before maintenance.

●During the warranty period, the following repairs need to be paid:
a.Unable to offer valid warranty card or certificate;

b.The purchase date, sales company and other items are not completely filled or the warranty card is altered;

c.Damage caused by failure to follow the use methods and precautions in the manual;

d.Damage caused by disassembly, repair and modification of products without authorization of the manufacturer;

e.Replacement of vulnerable and consumable parts.

●All items of the warranty card shall be completely filled in by the agent or user to obtain a 12-month warranty period.

●Please keep this warranty card properly It will not be re-offered after.

QUICK INTELLIGENT EQUIPMENT
CO., LTD.

ADD: NO.11, FengXiang Road, Wujin
High-Tech Industrial Development
Zone, Jiangsu, China

TEL: 86-519-86225678

FAX: 86-519-86558599

POSTCODE: 213167

WEBSITE: www.quick-global.com

Warranty Card

Type: _____

Model No.: _____

Serial No.: _____

Delivery Date: _____

Warranty File Card

Type: _____

Model No.: _____

Serial No.: _____

Delivery Date: _____

Address : _____

Postcode: _____

Telephone: _____

Contact Person: _____

QUICK INTELLIGENT EQUIPMENT CO., LTD.

ADD: NO.11, FengXiang Road, Wujin
High-Tech Industrial Development Zone,
Jiangsu, China

TEL: 86-519-86225678

FAX: 86-519-86558599

POSTCODE: 213167

WEBSITE: www.quick-global.com

