

CD4073 CMOS Triple 3 Input AND Gate

1. General Description

1.1 Description

CD4073 AND gate provides the system designer with direct implementation of the AND function and supplement the existing family of CMOS gates. All inputs and outputs are buffered.

1.2 Features

- Buffered inputs and outputs
- Standardized symmetrical output characteristics

- 100% tested for quiescent current at 18V
- Maximum input current of 1μA at 18V and 25°C
- 5V,10V, and 15V parametric ratings

1.3 Device Information

PART NUMBER	PACKAGE
CD4073	DIP
	SOP
	TSSOP

2. Pin Description and Functional Diagram

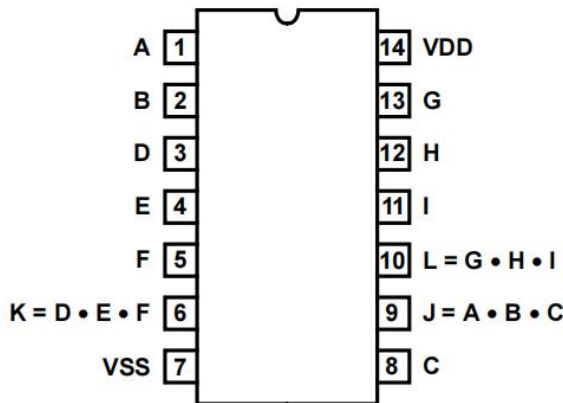

Figure 2.1 Top View

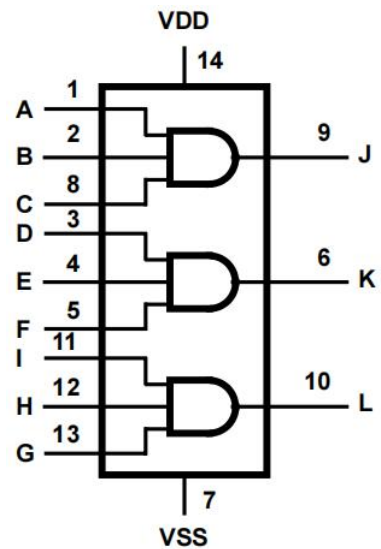

Figure 2.2 Functional Diagram

PIN No.	NAME	I/O	FUNCTION
1	A	I	Data Input
2	B	I	Data Input
3	D	I	Data Input
4	E	I	Data Input
5	F	I	Data Input
6	K	O	Data Output, $K=D \cdot E \cdot F$
7	VSS		Ground
8	C	I	Data Input
9	J	O	Data Output, $J=A \cdot B \cdot C$
10	L	O	Data Output, $L=G \cdot H \cdot I$
11	I	I	Data Input
12	H	I	Data Input
13	G	I	Data Input
14	VDD		Supply Voltage

3. System Diagram

3.1 Logic Diagram

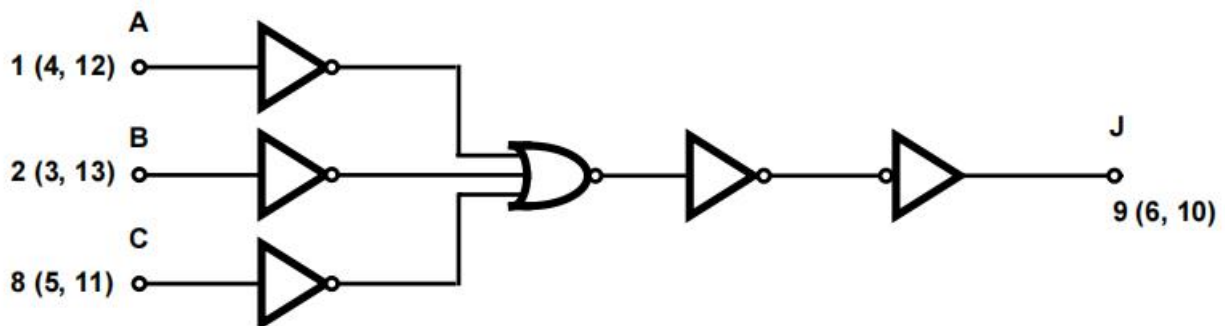

Figure 3.1: CD4073 Logic Diagram(1 of 3 identical gates)

3.2 Truth Table

Input			Output
A	B	C	Y
0	X	X	0
X	0	X	0
X	X	0	0
1	1	1	1

X = Don't Care, 1 ≡ High State, 0 ≡ Low State



4. Specifications

4.1 Absolute Maximum Ratings

Symbol	Parameter	MIN	MAX	Unit
V_{DD}	DC Supply Voltage Range (Voltage Referenced to VSS Terminals)	-0.5	20	V
V_I	Input Voltage Range, All Inputs	0.5	$V_{DD}+0.5$	V
P_D	Power Dissipation		500	mW
T_J	Junction Temperature		125	°C
T_{OP}	Operating Temperature	-40	85	°C

Absolute maximum ratings are those values beyond which the device could be permanently damaged, These are stress ratings only, which do not imply functional operation of the device at these or any other conditions beyond those indicated under normal operating conditions.

4.2 Electrical Characteristics

($T_a=25^{\circ}\text{C}$, voltages are referenced to VSS (ground=0V), unless otherwise specified)

Symbol	Parameter	Test Condition			MIN	TYP	MAX	Unit
		VO	VIN	VDD				
I_{DD}	Supply Current	--	0,5	5	--	0	1	uA
		--	0,10	10	--	0	1	uA
		--	0,18	18	--	0	1	uA
I_{OL}	Low Level Output Current	0.4	0,5	5	1	2	--	mA
		0.5	0,10	10	2	4	--	mA
		1.5	0,15	15	8	16	--	mA
I_{OH}	High Level Output Current	4.6	0,5	5	-0.5	-1	--	mA
		2.5	0,5	5	-2	-5	--	mA
		9.5	0,10	10	-1.3	-2.6	--	mA
		13.5	0,15	15	-5	-10	--	mA
V_{OL}	Low Level Output Voltage	--	0,5	5	--	0	0.05	V
		--	0,10	10	--	0	0.05	V
		--	0,15	15	--	0	0.05	V
V_{OH}	High Level Output Voltage	--	0,5	5	4.95	5	--	V
		--	0,10	10	9.95	10	--	V
		--	0,15	15	14.95	15	--	V
V_{IL}	Low Level Input Voltage	0.5,4.5	--	5	--	--	1.5	V
		1,9	--	10	--	--	3	V
		1.5,13.5	--	15	--	--	4	V
V_{IH}	High Level Input Voltage	0.5,4.5	--	5	3.5	--	--	V
		1,9	--	10	7	--	--	V
		1.5,13.5	--	15	11	--	--	V
I_{IN}	Input Leakage Current	--	0,18	18	--	0	±1	uA



5. Ordering Information

Orderable Device	Package Type	Pins	Packing	Package Qty
CD4073ND14ATBE	DIP	14	Tube	25
CD4073NS14ARDQ	SOP	14	Tape & Reel	4000
CD4073TS14ARDQ	TSSOP	14	Tape & Reel	4000

6. Package Information

6.1 DIP14

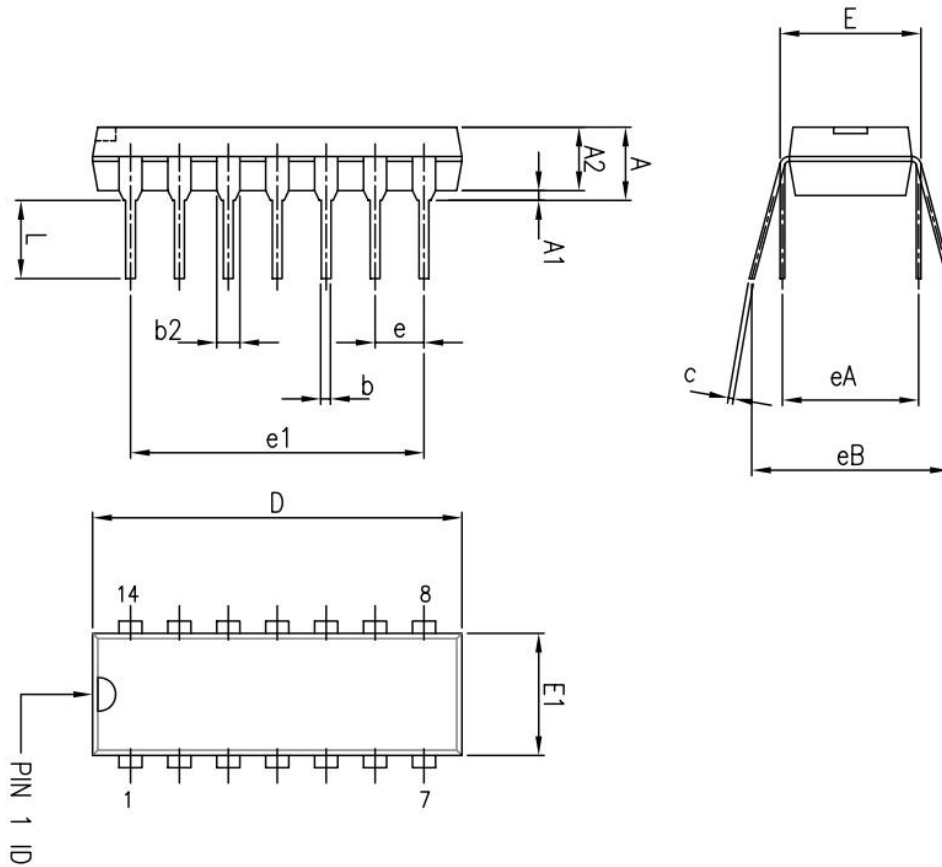

Dimensions						
Ref.	Millimeters			Inches		
	Min.	Typ.	Max.	Min.	Typ.	Max.
A			5.33			0.21
A1	0.38			0.015		
A2	2.92	3.30	4.95	0.11	0.13	0.19
b	0.36	0.46	0.56	0.014	0.018	0.022
b2	1.14	1.52	1.78	0.04	0.06	0.07
c	0.20	0.25	0.36	0.007	0.009	0.01
D	18.67	19.05	19.69	0.73	0.75	0.77
E	7.62	7.87	8.26	0.30	0.31	0.32
E1	6.10	6.35	7.11	0.24	0.25	0.28
e		2.54			0.10	
e1		15.24			0.60	
eA		7.62			0.30	
eB			10.92			0.43
L	2.92	3.30	3.81	0.11	0.13	0.15

6.2 SOP14

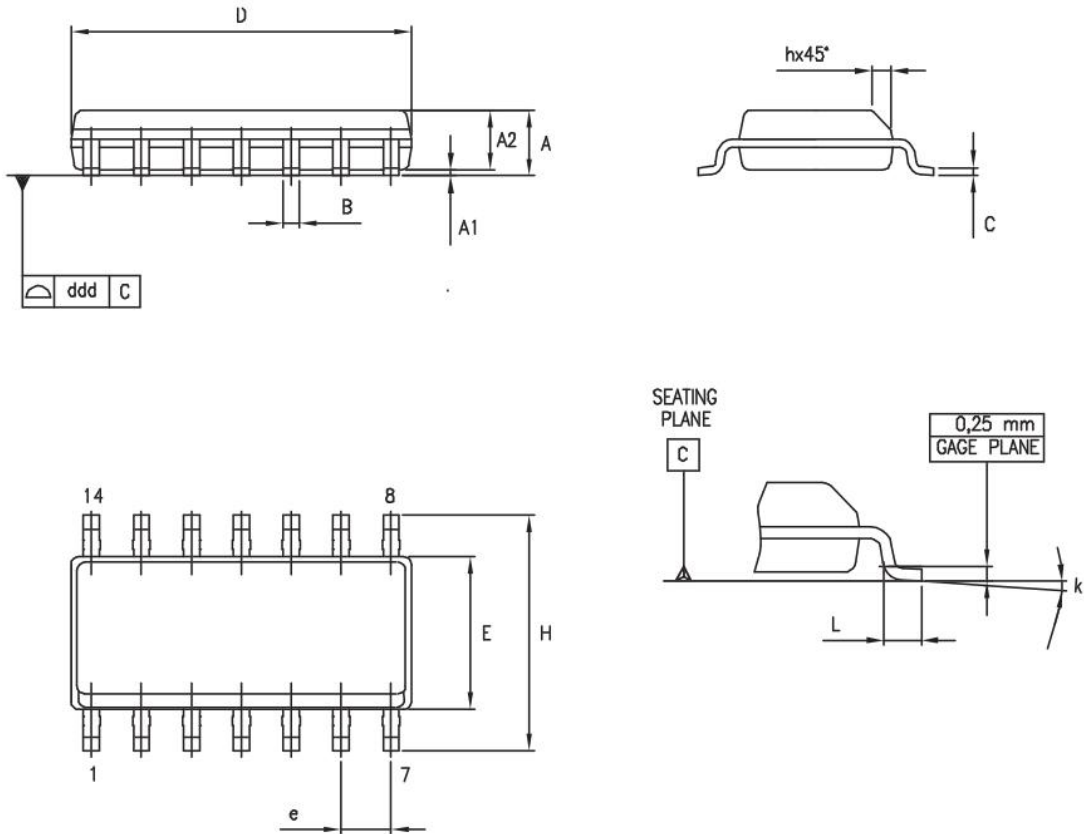

Dimensions						
Ref.	Millimeters			Inches		
	Min.	Typ.	Max.	Min.	Typ.	Max.
A	1.35		1.75	0.05		0.068
A1	0.10		0.25	0.004		0.009
A2	1.10		1.65	0.04		0.06
B	0.33		0.51	0.01		0.02
C	0.19		0.25	0.007		0.009
D	8.55		8.75	0.33		0.34
E	3.80		4.0	0.15		0.15
e		1.27			0.05	
H	5.80		6.20	0.22		0.24
h	0.25		0.50	0.009		0.02
L	0.40		1.27	0.015		0.05
k	8° (max.)					
ddd			0.10			0.004

6.3 TSSOP14

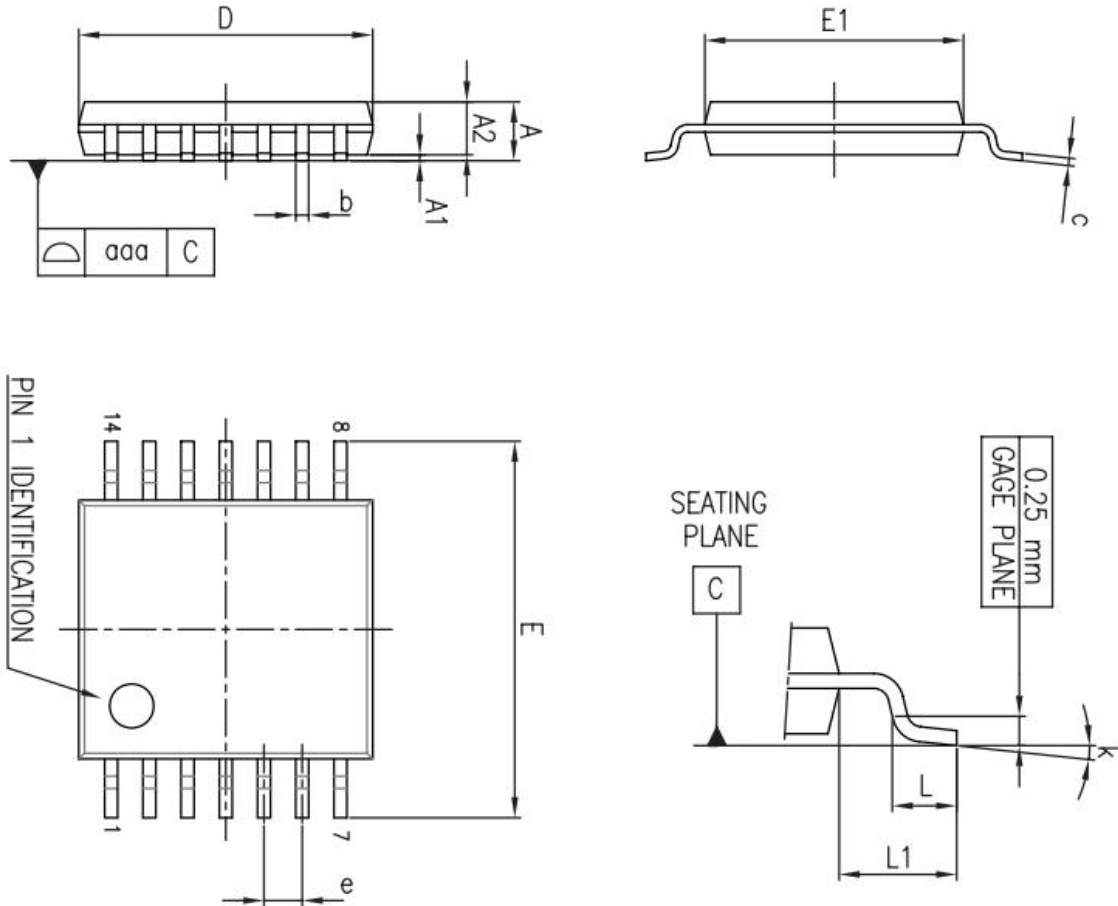

Ref.	Dimensions					
	Millimeters			Inches		
	Min.	Typ.	Max.	Min.	Typ.	Max.
A			1.20			0.047
A1	0.05		0.15	0.002	0.004	0.006
A2	0.80	1.00	1.05	0.031	0.039	0.041
b	0.19		0.30	0.007		0.012
c	0.09		0.20	0.004		0.0089
D	4.90	5.00	5.10	0.193	0.197	0.201
E	6.20	6.40	6.60	0.244	0.252	0.260
E1	4.30	4.40	4.50	0.169	0.173	0.176
e		0.65			0.0256	
L	0.45	0.60	0.75	0.018	0.024	0.030
L1		1.00			0.039	
k	0°		8°	0°		8°
aaa			0.10			0.004